



CARIBBEAN EXAMINATIONS COUNCIL

# CSEC<sup>®</sup> Biology

**SYLLABUS  
SPECIMEN PAPER  
MARK SCHEME  
SUBJECT REPORTS**

Macmillan Education Ltd  
4 Crinan Street, London, N1 9XW  
A division of Springer Nature Limited  
Companies and representatives throughout the world  
[www.macmillan-caribbean.com](http://www.macmillan-caribbean.com)

ISBN 978-0-230-48203-6

© Caribbean Examinations Council (CXC®) 2021  
[www.cxc.org](http://www.cxc.org)  
[www.cxc-store.com](http://www.cxc-store.com)

The author has asserted their right to be identified as the author of this work in accordance with the Copyright, Design and Patents Act 1988.

First published 2014

This revised edition published November 2021

#### Permission to copy

The material in this book is copyright. However, the publisher grants permission for copies to be made without fee. Individuals may make copies for their own use or for use by classes of which they are in charge; institutions may make copies for use within and by the staff and students of that institution. For copying in any other circumstances, prior permission in writing must be obtained from Macmillan Publishers Limited. Under no circumstances may the material in this book be used, in part or in its entirety, for commercial gain. It must not be sold in any format.

Designed by Macmillan Education Limited

Cover design by Macmillan Education Limited and Red Giraffe

## **CSEC Biology Free Resources**

### **LIST OF CONTENTS**

<b>CSEC Biology Syllabus Extract</b>	<b>3</b>
<b>CSEC Biology Syllabus</b>	<b>4</b>
<b>CSEC Biology Specimen Papers:</b>	
Paper 01	89
Paper 02	104
Paper 032	125
<b>CSEC Biology Mark Schemes for Specimen Papers:</b>	
Paper 01	136
Paper 02	137
Paper 032	149
<b>CSEC Biology Subject Reports:</b>	
2004 January Subject Report	154
2004 June Subject Report	173
2005 January Subject Report	188
2006 January Subject Report	205
2007 January Subject Report	220
2007 May/June Subject Report	237
2008 January Subject Report	257
2008 May/June Subject Report	274
2009 January Subject Report	292
2009 May/June Subject Report	306
2010 January Subject Report	327
2011 January Subject Report	340
2011 May/June Subject Report	349
2012 January Subject Report	366
2012 May/June Subject Report	378
2013 May/June Subject Report	397
2014 January Subject Report	415
2014 May/June Subject Report	431
2015 January Subject Report	448
2015 May/June Subject Report	462
2016 January Subject Report	477
2016 May/June Subject Report	491
2017 January Subject Report	501
2018 January Subject Report	516
2018 May/June Subject Report	529
2019 January Subject Report	549
2019 May/June Subject Report	560
2020 January Subject Report	581
2020 May/June Subject Report	605
2021 January Subject Report	615

## **Biology**

Biology is the discipline in science which seeks to understand the organisation of the organic world through an exploration of the structure and function of life forms at the molecular, cellular, organismal and ecosystem levels, as well as the complex interactions and interdependencies which occur at each of these levels. This knowledge provides the foundation for understanding the opportunities for promoting the well-being of humans and other living organisms in the environment. It generates an awareness of the importance of our biodiversity and the unique role of humans in conserving, protecting and improving the quality of the biological environment for future generations.

The CSEC Biology syllabus has been redesigned with a greater emphasis on the application of scientific concepts and principles. It recognises the need for an understanding of some of the basic principles of Chemistry, Physics and Mathematics, and therefore seeks to strengthen the inter-relationship with these subjects. It also recognises the inter-relatedness among the topics in Biology, and social and environmental issues. Such an approach is adopted to develop those long-term transferable skills of ethical conduct, team work, problem-solving, critical thinking, and innovation and communication. It encourages the use of various teaching and learning strategies to inculcate these skills that will prove useful in everyday life, while at the same time catering to multiple intelligences and different learning styles and needs. It will provide a sound foundation to pursue the study of Life Sciences and related professions at the post-secondary level.

The syllabus is arranged in three sections namely:

- Section A Living Organisms in the Environment
- Section B Life Processes and Disease
- Section C Continuity and Variation





**CARIBBEAN EXAMINATIONS COUNCIL**

**Caribbean Secondary Education Certificate®  
CSEC®**

# **BIOLOGY SYLLABUS**

**Effective for examinations from May–June 2015**



Published by the Caribbean Examinations Council

All rights reserved. No part of this publication may be reproduced, stored in a retrieval system, or transmitted in any form, or by any means electronic, photocopying, recording or otherwise without prior permission of the author or publisher.

Correspondence related to the syllabus should be addressed to:

The Pro-Registrar  
Caribbean Examinations Council  
Caenwood Centre  
37 Arnold Road, Kingston 5, Jamaica

Telephone Number: + 1 (876) 630-5200

Facsimile Number: + 1 (876) 967-4972

E-mail Address: [cxcwzo@cxc.org](mailto:cxcwzo@cxc.org)

Website: [www.cxc.org](http://www.cxc.org)

Copyright © 2013 by Caribbean Examinations Council  
The Garrison, St Michael BB14038, Barbados





# Content

RATIONALE .....	1
AIMS .....	2
CANDIDATE POPULATION.....	2
SUGGESTED TIME-TABLE ALLOCATION.....	3
ORGANISATION OF THE SYLLABUS.....	3
SUGGESTIONS FOR TEACHING THE SYLLABUS.....	3
CERTIFICATION AND DEFINITION OF PROFILES .....	4
FORMAT OF THE EXAMINATIONS .....	6
REGULATIONS FOR PRIVATE CANDIDATES .....	7
REGULATIONS FOR RESIT CANDIDATES .....	7
THE PRACTICAL APPROACH .....	7
SECTION A - LIVING ORGANISMS IN THE ENVIRONMENT.....	12
SECTION B - LIFE PROCESSES <i>AND DISEASE</i> .....	19
SECTION C - CONTINUITY AND VARIATION.....	37
APPENDIX I - GUIDELINES FOR SCHOOL-BASED ASSESSMENT.....	45
APPENDIX II - RECOMMENDED MINIMUM EQUIPMENT LIST.....	73
APPENDIX III - RECOMMENDED MATERIAL LIST.....	74
APPENDIX IV - RESOURCE MATERIALS .....	75
APPENDIX V - GLOSSARY.....	76



This document CXC 20/G/SYLL 13 replaces CXC 20/G/SYLL/02 issued in 2002.

Please note that the syllabus has been revised and amendments are indicated by italics.

First published 1983  
Reprinted with amendments 1986, 1987  
Revised 1991, 1996, 2002, 2013

Please check the website [www.cxc.org](http://www.cxc.org) for updates on CXC's syllabuses.





# Biology Syllabus

## ◆ RATIONALE

*The application of scientific principles and the conduct of relevant research are of significant importance in identifying, assessing and realising the potential of the resources of Caribbean territories. A good foundation in the sciences will enhance the ability of our citizens to respond to the challenges of a rapidly changing world using the scientific approach.*

*Biology is the discipline in science which seeks to understand the organisation of the organic world through an exploration of the structure and function of life forms at the molecular, cellular, organismal and ecosystem levels, as well as the complex interactions and interdependencies which occur at each of these levels. This knowledge provides the foundation for understanding the opportunities for promoting the well-being of humans and other living organisms in the environment. It generates an awareness of the importance of our biodiversity and the unique role of humans in conserving, protecting and improving the quality of the biological environment for future generations.*

*The CSEC Biology Syllabus is redesigned with a greater emphasis on the application of scientific concepts and principles. It recognises the need for an understanding of some of the basic principles of Chemistry, Physics and Mathematics, and, therefore seeks to strengthen the inter-relationship with these subjects. It also recognises the inter-relatedness among the topics in Biology, and social and environmental issues. Such an approach is adopted to develop those long-term transferable skills of ethical conduct, team work, problem-solving, critical thinking, and innovation and communication. It encourages the use of various teaching and learning strategies to inculcate these skills that will prove useful in everyday life, while at the same time catering to multiple intelligences and different learning styles and needs. It will provide a sound foundation to pursue the study of Life Sciences and related professions at the post-secondary level.*

*This syllabus will contribute to the development of the Ideal Caribbean Person as articulated by the CARICOM Heads of Government in the following areas: respect for human life and awareness of the importance of living in harmony with the environment; demonstrates multiple literacies; independent and critical thinking and the innovative application of science and technology to problem solving. In keeping with the UNESCO Pillars of Learning, this course of study will also contribute to a person who will learn how to do, learn to live together and learn to transform themselves and society.*

## ◆ AIMS

The syllabus aims to:

1. develop an understanding of fundamental biological principles and concepts (such as structure and function relationships; unity in diversity; energy transduction), based upon practical and theoretical knowledge of living organisms and the environment;
2. make accurate observations of biological material and phenomena, both in the field and in the laboratory;
3. develop the ability to record information accurately;
4. formulate hypotheses and plan, design and carry out experiments to test them;
5. *develop the ability to appraise information critically, identify patterns, cause and effect, stability and change and evaluate ideas;*
6. appreciate that although generalisations have predictive value, there are often exceptions to them;
7. develop problem-solving and critical thinking skills;
8. develop an awareness that principles of Chemistry, Physics, Mathematics and other disciplines are necessary for a proper understanding of Biology;
9. recognise the dynamic nature of the interrelationships between organisms and their environment;
10. develop a natural curiosity about living organisms and a respect for all living things and the environment;
11. *develop the ability to work independently and collaboratively with others when necessary;*
12. apply biological knowledge for further studies as well as in everyday life situations;
13. acknowledge the social and economic implications of Biology;
14. integrate Information Communication and Technology (ICT) tools and skills.

## ◆ CANDIDATE POPULATION

The syllabus is designed for students intending to pursue further studies in science at the tertiary level as well as for students whose formal study of the subject is unlikely to proceed further.

### CANDIDATE REQUIREMENTS

1. Candidates should have been exposed to at least three years of science at the secondary level, which should provide an introduction to basic physical and biological principles.



2. Candidates should be concurrently studying or have done:
- (a) CSEC Mathematics or its equivalent;
  - (b) CSEC English A (English Language) or its equivalent.

#### **CLASS SIZE**

It is recommended that practical classes accommodate a maximum of **twenty-five** students.

### ◆ **SUGGESTED TIME-TABLE ALLOCATION**

It is recommended that a minimum of five 40-minute periods per week, including one double period, be allocated to the subject over a two-year period.

### ◆ **ORGANISATION OF THE SYLLABUS**

The syllabus is arranged in three sections, namely:

SECTION A - Living Organisms in the Environment

SECTION B - Life Processes and Disease

SECTION C - Continuity and Variation

### ◆ **SUGGESTIONS FOR TEACHING THE SYLLABUS**

*It is recommended that Section A be taught first, followed by Sections B and C.*

*The organisation of each section in the syllabus is designed to facilitate inquiry-based learning and to ensure that connections among biological concepts are established. Teachers should ensure that their lessons stimulate the use of all of the senses in learning as this will help students view science as a dynamic and exciting investigative process.*

*The general and specific objectives indicate the scope of the content including practical work that should be covered. However, unfamiliar situations may be presented as stimulus material in examination questions.*

*This syllabus caters to varying teaching and learning styles, with specific attention being drawn to the interrelatedness of concepts. The fourth column entitled, "Skills and Interrelationships" states which specific objectives are best suited for the assessment of Drawing (DR), Observation, Recording and Reporting (ORR), Manipulation and Measurement (MM), Analysis and Interpretation (AI), and Planning and Designing (PD) skills. Whenever possible, a practical approach should be employed, with special attention given to the identification of variables and to the use of controls in biological investigations. Students should be encouraged to use information gathering tools and social networking media to aid investigation and teamwork. The need for repeated investigation and observations to arrive at meaningful conclusions should be emphasised.*



Column four also highlights connections between biological concepts and the fields of Chemistry, Physics, Mathematics and other related disciplines. In order to make the course as relevant as possible, students' awareness of the effect of science on society and on the environment should be encouraged. All aspects of the environment: social, biological and physical must be considered in totality.

Greater emphasis should be placed on the application of scientific concepts and principles and less on the factual materials, which encourage memorisation and short-term recall. Every opportunity should be made to relate biological studies to the environment, and to use an ecological approach whenever pertinent. Biological principles should be illustrated by specific local and regional examples. Common names of organisms are acceptable.

The relationship between structure and function, cause and effect, stability and change is to be continually highlighted. Where appropriate, this relationship should be illustrated by the use of annotated diagrams.

The role of the teacher is to facilitate students' learning of accurate and unbiased information that will contribute to a more scientifically literate society that is capable of making educated and ethical decisions regarding the world we live in.

## ◆ CERTIFICATION AND DEFINITION OF PROFILES

The syllabus will be examined for General Proficiency certification.

In addition to the overall grade, there will be a profile report on the candidate's performance under the following headings:

- (a) Knowledge and Comprehension;
- (b) Use of Knowledge;
- (c) Experimental Skills.

### Knowledge and Comprehension (KC)

Knowledge

The ability to:

identify, remember, and grasp the meaning of basic facts, concepts and principles;

Comprehension

select appropriate ideas, match, compare and cite examples of facts, concepts and principles in familiar situations.

### Use of Knowledge (UK)

The ability to:

Application

use facts and apply concepts, principles and procedures in familiar and novel situations; transform data accurately and appropriately; use formulae accurately for computational purposes;





Analysis and Interpretation	identify and recognise the component parts of a whole and interpret the relationship among those parts; identify causal factors and show how they interact with each other; infer, predict and draw conclusions; make necessary and accurate calculations and recognise the limitations and assumptions inherent in the collection and interpretation of data;
Synthesis	combine component parts to form a new and meaningful whole; make predictions and solve problems;
Evaluation	make reasoned judgements and recommendations based on the value of ideas, information and their implications.

**Experimental Skills – (XS)**

Manipulation/Measurement	<p>The ability to:</p> <p>follow a detailed set or sequence of instructions;</p> <p>use techniques, apparatus and materials safely and effectively;</p> <p>make observations and take measurements with due regard for precision and accuracy.</p>
--------------------------	--

Observation/Recording/Reporting	<p>The ability to:</p> <p>select observations relevant to the particular activity;</p> <p>make accurate observations and minimise experimental errors;</p> <p>report and recheck unexpected results;</p> <p>select and use appropriate models of recording data or observations, for example, graphs, tables, diagrams;</p> <p>record observations, measurements, methods and techniques with due regard for precision, accuracy, and units;</p> <p>present data in an appropriate manner, using the accepted convention of recording errors and uncertainties;</p> <p>organise and present information, ideas, descriptions and arguments clearly and logically in a complete report, using spelling, punctuation and grammar with an acceptable degree of accuracy;</p> <p>report accurately and concisely using scientific terminology and conventions as necessary.</p>
---------------------------------	---

Planning and Designing

The ability to:

make predictions, develop hypotheses and devise means of carrying out investigations to test them;

plan and execute experimental procedures and operations in an appropriate sequence;

use experimental controls where appropriate;

modify an original plan or sequence of operations as a result of difficulties encountered in carrying out experiments or obtaining unexpected results;

take into account possible sources of errors and precaution in the design of an experiment;

select and use appropriate equipment and techniques.

## ◆ FORMAT OF THE EXAMINATIONS

Paper 01  
(1 hour 15 minutes)

An objective test consisting of 60 multiple choice items.

Paper 02  
(2 hours 30 minutes)

One compulsory data analysis question, two structured questions and three extended response questions.

Paper 03/1  
School-Based Assessment (SBA)

School-Based Assessment will evaluate the achievement of the candidate in the Experimental Skills and Analysis and Interpretation involved in the laboratory and fieldwork. Candidates will be required to keep a separate practical workbook. CXC will require a sample of these for external moderation.

Paper 03/2  
Assessment for  
Private candidates only  
(2 hours 10 minutes)

Alternate to the School-Based Assessment for private candidates. This paper will examine the same skills as those tested in Paper 03/1. The focus, therefore, will be on Experimental Skills and Use of Knowledge (Analysis and Interpretation).

### NOTES ON THE EXAMINATION

1. There will be a combined Question Paper and Answer Booklet for Paper 02.
2. The International System of Units (S. I. Units) will be used on all examinations papers.

### WEIGHTING OF PAPERS AND PROFILES

The percentage weighting of each paper and profile is presented in Table 1.

**Table 1**  
**Percentage Weighting of Papers and Profiles**

<b>PROFILES</b>	<b>PAPER 1</b> <i>Multiple Choice</i>	<b>PAPER 2</b> <i>Structured and Data Analysis</i>	<b>PAPER 3</b> <i>SBA</i>	<b>TOTAL RAW</b>	<b>TOTAL %</b>
<i>Knowledge and Comprehension</i>	60	36	-	96	48
<i>Use of Knowledge</i>	-	55	10	65	32.5
<i>Experimental Skills</i>	-	9	30	39	19.5
<b>TOTAL %</b>	<b>60</b>	<b>100</b>	<b>40</b>	<b>200</b>	<b>100</b>

### ◆ REGULATIONS FOR PRIVATE CANDIDATES

Private candidates must be entered for examination through the Local Registrar in their respective territories and will be required to sit Papers 01, 02 and 03/2.

Paper 03/2 is a practical examination designed for candidates whose work cannot be monitored by tutors in recognised educational institutions. The Paper will be of 2 hours and 10 minutes duration and will consist of three questions. Questions will test the Experimental Skills and Use of Knowledge (Analysis and Interpretation) profiles and will incorporate written exercises and practical activities.

### ◆ REGULATIONS FOR RESIT CANDIDATES

Resit candidates must complete Papers 01 and 02 and Paper 03 of the examination for the year for which they re-register. Resit candidates may elect not to repeat the School-Based Assessment component, provided they re-write the examination no later than two years following their first attempt.

*Candidates may opt to complete the School-Based Assessment (SBA) or may opt to re-use another SBA score which satisfies the condition below.*

*A candidate who re-writes the examination within two years may re-use the moderated SBA score earned in the previous sitting within the preceding two years. Candidates re-using SBA scores in this way must register as “Resit candidates” and provide the previous candidate number.*

All resit candidates may enter through schools, recognized educational institutions, or the Local Registrar’s Office.

### ◆ THE PRACTICAL APPROACH

*The syllabus is designed to foster the use of inquiry-based learning through the application of the practical approach. Students will be guided to answer scientific questions by a process of making observations, asking questions, doing experiments and analyzing and interpreting data. The CSEC Biology Syllabus focuses on the following skills.*

1. Planning and Designing (PD)

- (a) *Ask questions: how, what, which, why or where. (Students must be guided by their teachers to ask scientific questions).*

*Observation: Growth of plants are affected by their environment.*

*Example: Will plants that are grown using organic fertilizers grow taller than those that are grown using inorganic fertilizers?*

- (b) *Construct a hypothesis; the hypothesis must be clear, concise and testable.*

*Example: Plants grown using organic fertilizer will grow taller than those grown using inorganic fertilizer.*

- (c) *Design an experiment to test the hypothesis. Experimental reports must include the following:*

- (i) problem statement;*
- (ii) an appropriate aim related to the hypothesis;*
- (iii) list of materials and apparatus to be used;*
- (iv) observations to be made or measurements to be taken;*
- (v) precautions to be taken;*
- (vi) method of controlling variables;*
- (vii) clear and concise step by step procedure;*
- (viii) display of expected results;*
- (ix) use of results;*
- (x) possible limitations.*

2. Measurement and Manipulation (MM)

- (a) *Student's ability to handle scientific equipment competently.*

*The list of equipment is:*

- (i) Bunsen burner;*
- (ii) Tripod stand with wire gauze;*
- (iii) binocular and monocular light microscope;*
- (iv) measuring cylinders (25-100cm<sup>3</sup>);*
- (v) beaker (50-500cm<sup>3</sup>);*



- (vi) thermometer;
  - (vii) ruler;
  - (viii) stop watch/clock;
  - (ix) balance;
  - (x) boiling tube;
  - (xi) test tubes and test tube holders;
  - (xii) hand lens;
  - (xiii) syringe.
- (b) Student's ability to take accurate measurements.
- (c) Student's ability to use appropriate units.

3. Observation, Reporting and Recording (ORR)

(a) Recording

*Student's ability to record observations and to collect, organise and present data. Observations and data may be recorded in the following format.*

- (i) *Prose*  
*Written description of observations in the correct tense.*
- (ii) *Table (Neatly enclosed)*  
*Numerical: physical quantities in heading, units stated in heading, symbols, decimal points.*  
*Non-numerical: headings correct, details present.*
- (iii) *Graph*  
*Axes labelled, correct scales, correct plotting, smooth curves/best fit lines, key to explain symbols if more than one dependent variable is being plotted.*

(b) Reporting

*Student's ability to prepare a comprehensive written report on their assignments using the following format:*

- (i) **Date** (date of experiment).
- (ii) **Aim/Purpose** (what is the reason for doing the experiment).
- (iii) **Apparatus and Materials** (all equipment, chemicals and materials used in the experiment must be listed).



- (iv) **Method/Experimental Procedure** (logically sequenced, step-by-step procedure written in the past tense, passive voice).
- (v) **Results and Observations** (see a above: Observation/ Recording/Recording).
- (vi) **Discussion and Conclusion** (see 4 below: Analysis and Interpretation).

4. Analysis and Interpretation

Student's ability to:

- (a) identify patterns and trends, cause and effect, stability and change ;
- (b) make accurate calculations;
- (c) identify limitations and sources of error, make a conclusion to either support or refute the hypothesis, compare actual results with expected results based on background/theoretical knowledge if they are different;
- (d) suggest alternative methods or modification to existing methods;
- (e) analysing and interpreting results and observations and making conclusions.

5. Drawing (Dr)

The following guidelines should be used for drawing.

- (a) The drawing should be placed in a position on the page which will allow for neat and clear labelling.
- (b) If the drawing/diagram is included in the written material, it should be placed just before this material and should be referred to in your answer.
- (c) Drawings should be done in pencil. The use of coloured pencils is not recommended.
- (d) The drawing should be large enough so that all structures can be clearly drawn.
- (e) The drawing should be correctly proportioned and parts should be accurately positioned.
- (f) In order to get a smooth, unbroken line when drawing, lift the pencil from the paper as infrequently as possible until the line is completely drawn. This method will help to eliminate haphazard and sketchy lines.
- (g) When a large number of small structures are present in a specimen, draw only a few of them carefully, showing structural details.
- (h) Write labels in pencil.
- (i) Labels should be annotated (that is, accompanied by brief explanatory notes).



- (j) *Label lines should never cross each other and should be horizontal where possible.*
- (k) *In drawings where only a few structures are being labelled, all labels should be written on the right of the drawing.*
- (l) *Drawings must have a full title and magnification. This is usually written below the drawing and underlined. The title tells the name of the structure or organism and the view from which the drawing was made.*

## ◆ SECTION A - LIVING ORGANISMS IN THE ENVIRONMENT

*SECTION A is designed as an introduction to the rest of the syllabus. It is expected that in the teaching of this section, students will work in groups outside of the classroom in order to study the interrelationships between organisms and their environment and to better facilitate their appreciation of the diversity and complexity of these relationships.*

### GENERAL OBJECTIVES

On completion of this Section, students should:

1. be aware that there is both diversity and similarity of form in living organisms;
2. understand the importance of the abiotic environment to living organisms;
3. understand that there is interdependence between living organisms and their environment;
4. understand that there is a flow of energy through living organisms within the ecosystem;
5. appreciate the finite nature of the 'worlds' resources *and the significance of recycling materials in nature;*
6. *be aware of the effect of human activities on the environment;*
7. apply the knowledge of the interrelationship of organisms with the environment to identify problems affecting the growth and survival of populations.

SPECIFIC OBJECTIVES	CONTENT/EXPLANATORY NOTES	SUGGESTED PRACTICAL ACTIVITIES	SKILLS AND INTER-RELATIONSHIPS
Students should be able to:			
1.1. <i>group living organisms found in a named habitat based on observed similarities and differences;</i>	<i>Visible characteristics, such as hairiness, colour, shape, venation, number of legs and wings, and body segmentation of organs found in both plants and animals as appropriate. Common names of organisms and groups are acceptable.</i>	<i>Nature walks. Organise students in groups to observe organisms (plants and/or animals) in their natural habitat.</i>	<i>Skills: ORR; Dr.</i>
1.2. <i>classify organisms into taxonomic groups based on physical similarities;</i>	<i>Simple classification of all living organisms into the five kingdoms: Plantae, Animalia; Fungi (mushroom), Prokaryotae (Bacteria) and Proctotista (amoeba). Further subdivision of the Animal Kingdom into Phyla, for example, Chordata which</i>	<i>Make drawings and construct tables to record observations.</i>	<i>Continuity and Variation Skill: Dr.</i>





## SECTION A - LIVING ORGANISMS IN THE ENVIRONMENT (cont'd)

SPECIFIC OBJECTIVES	CONTENT/EXPLANATORY NOTES	SUGGESTED PRACTICAL ACTIVITIES	SKILLS AND INTER-RELATIONSHIPS
Students should be able to:	<p><i>includes Classes (fish, reptiles, insects, birds mammals). These are further classified to the level of species. Modern classification uses DNA sequences to determine ancestry. Refer to SO A 2.2; B 1.1</i></p> <p><i>Note: Flowcharts could be included with drawings under Practical activities.</i></p>		
2.1 carry out a simple ecological study using the most appropriate collecting and sampling methods;	<p><i>Habitats may include terrestrial and aquatic, for example, a tree, wall or small pond.</i></p> <p>Features of each habitat. Relationship between organism and habitat – adaptations that enable the organism(s) to survive in that habitat.</p> <p>Relationship between equipment used and habitat and species being investigated.</p>	<p><i>Use quadrats to investigate the distribution of species in a particular habitat; estimate the density of a particular species. Calculate average (mean). Density = Total No. of organisms per unit area.</i></p> <p>Use of pooters, bottles, jars, nets, sieves, quadrats, line and belt transects, mark, release and recapture methods to collect data on organisms from a named habitat.</p>	<p><i>Math - Simple statistical analysis.</i></p> <p><i>Data collection and presentation.</i></p> <p><i>Skills: ORR; MM; Dr; PD.</i></p>
2.2 distinguish between the following pairs of terms: (a) abiotic and biotic factors, (b) niche and habitat,	<p>Ecology – the study of living organisms in their environment. Ecosystem- a community of living organisms sharing an environment. Environment – <i>the</i> abiotic (non-living chemical and</p>		<p><i>Skill: ORR.</i></p>



## SECTION A - LIVING ORGANISMS IN THE ENVIRONMENT (cont'd)

SPECIFIC OBJECTIVES	CONTENT/EXPLANATORY NOTES	SUGGESTED PRACTICAL ACTIVITIES	SKILLS AND INTER-RELATIONSHIPS
Students should be able to:			
(c) population and community,	physical) and biotic (living) factors. Habitat - the place where a particular organism lives. Niche – the role of an organism in an ecosystem.		
(d) species and population;	Species – a group of individuals of common ancestry that closely resemble each other and are normally capable of interbreeding to produce a fertile offspring. Population – members of a particular species living in a particular habitat. Community – all the populations of different species found living in a particular habitat.		
2.3 discuss the impact of the abiotic factors (soil, water, climate) on living organisms;	Importance of soil in providing water, mineral nutrients and oxygen; importance of air in providing various raw materials: oxygen, carbon dioxide, nitrogen. Importance of light and temperature. Refer to SO A 5.1.	<i>Components of soil – air (O<sub>2</sub>) and, water-holding capacity, mineral nutrients, pH and salinity.</i>	<i>Chemistry - Elements, mixture and compounds; Oxidation; Decomposition Biodegradable; Recycling; Homeostasis.</i>  <i>Skills: ORR; MM.</i>
3.1 identify the relative positions of producers and consumers in food chains;	Construct food chains and simple pyramids.	<i>Provide a number of organisms from which to construct a food chain and a food web.</i>	<i>Interdependence on living organisms.</i>
3.2 identify from each habitat, a food chain containing at least four organisms;	<i>Terrestrial (arboreal and edaphic) and aquatic (marine and freshwater) habitats.</i>	<i>Construct food chains using organisms in each habitat.</i>	<i>Energy relations.</i>



## SECTION A - LIVING ORGANISMS IN THE ENVIRONMENT (cont'd)

SPECIFIC OBJECTIVES	CONTENT/EXPLANATORY NOTES	SUGGESTED PRACTICAL ACTIVITIES	SKILLS AND INTER-RELATIONSHIPS
Students should be able to:			
3.3 identify from each habitat: herbivore, carnivore and omnivore;	Not to be confined to familiar domestic animals.		
3.4 identify from each habitat, predator/ prey relationships;	<i>Terrestrial arboreal and edaphic) and aquatic (marine and fresh water) habitats. Example of the application of predator relationship. The use of 'Biological Controls'.</i>		<i>Link: Predator/Prey Relationships, Natural Selection.</i>
3.5 construct a food web to include different trophic levels;	Use of examples from the habitat(s) investigated. Students may be required to interpret a food web containing unfamiliar examples.	<i>Identify different trophic levels in food webs.</i>	<i>Energy Flow in an Ecosystem.</i>
3.6 <i>explain the role of decomposers;</i>	<i>Role of fungi and bacteria in converting complex compounds to simple substances.</i>	<i>Action of mould on bread, production of biogas from domestic organic waste material.</i>	<i>Chemistry- Hydrolysis. Enzyme. Nutrient cycling.</i>
3.7 <i>assess the special relationships among organisms;</i>	<i>Simple treatment of symbiotic relationships: parasitism, commensalism, mutualism - using local examples, such as lice and ticks on mammals, epiphytes on trees, nitrogen fixing bacteria in root nodules of legumes. Give names of partners.</i>	<i>Observations from a large tree. Examine root nodules, on the peanut plant.</i>	<i>Evolution Interdependence of living organisms and their environment. Skill: ORR.</i>
4.1 explain energy flow within a food chain or web;	<i>Simple diagram of non-cyclic energy flow from the sun.</i>		<i>Different forms of energy.</i>
5.1 explain, with examples, the impact of the continual re-use of materials in nature;	<i>Note the role of decomposers in the Carbon Cycle. Refer to SO A3.6.</i>		<i>Nutrient cycling.</i>



## SECTION A - LIVING ORGANISMS IN THE ENVIRONMENT (cont'd)

SPECIFIC OBJECTIVES	CONTENT/EXPLANATORY NOTES	SUGGESTED PRACTICAL ACTIVITIES	SKILLS AND INTER-RELATIONSHIPS
Students should be able to:			
5.2 discuss the importance of and difficulties encountered in recycling manufactured materials;	Consider biodegradable and non-biodegradable materials, collection, transport and storage; note economic factors.	<i>Interpret data on waste management and pollution in the Caribbean (See Caribbean Environmental Outlook).</i>	<i>Chemistry and Social Sciences.</i>
6.1 describe the impact of human activities on natural resources;	<i>Energy, mineral, forest, marine, over population and over fishing.</i>		<i>Alternative sources of energy.</i>
6.2 explain the negative impact of human activity on the environment;	Consider pollution by agricultural practices such as use of chemical fertilizers; products of industrialization and improper garbage disposal. Impact on eco-tourism.  <i>Loss of habitat, species; impact on human health.</i>	<i>Research projects. (For example, collect data on use of agricultural chemicals).</i>	
6.3 assess the implications of pollution of marine and wetland environments;	<i>Refer specifically to impact on the health of ecosystems, aesthetic and economic benefits to small island states.</i>	<i>Research and interpret data on pollution of marine environments in the Caribbean, for example, Coral reefs.</i>	
6.4 discuss current and future trends regarding climate change;	<i>Refer to increase in greenhouse gases, rising global temperatures, rising sea levels and ocean acidification. Particular attention should be paid to the vulnerability of small island states to climate change (See Barbados Action Plan). <a href="http://www.unep.ch/regionalseas/partners/sids.htm">http://www.unep.ch/regionalseas/partners/sids.htm</a>.</i>		<i>Chemistry- Natural versus synthetic Social Science – Impact of human activity.</i>



## SECTION A - LIVING ORGANISMS IN THE ENVIRONMENT (cont'd)

SPECIFIC OBJECTIVES	CONTENT/EXPLANATORY NOTES	SUGGESTED PRACTICAL ACTIVITIES	SKILLS AND INTER-RELATIONSHIPS
Students should be able to:			
6.5 suggest means by which the environment could be conserved and restored;	Consider effect of the change in practices; example use of natural materials in agriculture, conservation methods, education, monitoring strategies, organic agriculture.	<i>Research projects. (For example, describe a project involving conservation to include a listing the various strategies).</i>	
7.1 discuss the factors that affect the growth and survival of populations including human populations.	Include competition for food and space; effects of disease, pests, invasive species, natural disasters.	<i>Research projects. Analyse graphical data showing effect of different factors on natural populations, for example, giant snail.</i>	<i>Skill: AI.</i>

### **Suggested Teaching and Learning Activities**

*To facilitate students' attainment of the objectives of this Section, teachers are advised to engage students in the teaching and learning activities below. These activities are designed to promote inquiry-based learning and cater to students with various learning styles.*

- 1. Construct a poster depicting either a terrestrial, marine or freshwater food web that you would find in your country. Showcase how competition, adaptation, and energy flow play key roles in the process.*
- 2. Watch the videos on "Symbiotic Relationships" at PBS.org. <http://www.pbs.org/wnet/nature/lessons/symbiotic-strategies/video-segments/1496/>. Identify local examples of parasitism, commensalism, and mutualism in the Caribbean.*
- 3. Create a PowerPoint presentation, movie or poster on the importance of Marine and Coastal areas in the Caribbean (Interpret data on pages 56-63 in the Caribbean Environmental Outlook). [http://hqweb.unep.org/geo/GEO\\_Regions.asp](http://hqweb.unep.org/geo/GEO_Regions.asp) Identify at least TWO threats to these fragile ecosystems.*
- 4. Design a "Wanted" flyer for a criminal!! In this case, the criminal is an invasive species in the Caribbean, for example, the Small Indian Mongoose (*Herpestes auropunctatus*) and Lion fish. Invasive species are considered one of the greatest threats to island biodiversity and habitat loss. See examples of "Wanted Flyers" below: [http://science.nature.nps.gov/im/units/pacn/outreach/Invasive\\_species\\_trading\\_cards/NPSA\\_trading\\_cards.pdf](http://science.nature.nps.gov/im/units/pacn/outreach/Invasive_species_trading_cards/NPSA_trading_cards.pdf)*



## SECTION A - LIVING ORGANISMS IN THE ENVIRONMENT (cont'd)

5. *Discuss the main issues addressed by the 1994 Barbados Action Programme on the sustainable development of Small Island Developing States (SIDS).*
6. *Research the negative effects of climate change on your own community and write a short literary piece (short story, song, or poem) to present to the class.*
7. *Organise a debate regarding the positive and negative impacts of tourism development in your country and discuss the need for and importance of sustainable development in the Caribbean.*
8. *Arrange a debate on high population growth or high consumerism as principal causes of global environmental problems. See reports from the 1992 Rio Conference, the 1994, Barbados Programme of Action. (Note: Caribbean GEO).*
9. *Choose an environmental issue that concerns you (for example, the lack of recycling and the accumulation of plastics in the oceans which result in the death of marine mammals, invertebrates and sea turtles) or watch the video "Losing Paradise" <http://www.youtube.com/watch?v=vCanbznET3Y>. Write a convincing policy brief to be sent out to business owners, schools, and/or government officials in an effort to tackle this problem.*
10. *Interpret the data on forest cover in the Caribbean as presented in the Caribbean Environment Outlook by the United Nations Environmental Programme (UNEP) and CARICOM. [http://hqweb.unep.org/geo/GEO\\_Regions.asp](http://hqweb.unep.org/geo/GEO_Regions.asp) (Pages 34-38; [http://hqweb.unep.org/geo/pdfs/Caribbean\\_EO\\_final.pdf](http://hqweb.unep.org/geo/pdfs/Caribbean_EO_final.pdf)).*
11. *Interpret the data on the state of "Waste Management" and "Pollution" in the Caribbean. (See pages 44-48 in the Caribbean Environment Outlook); [http://hqweb.unep.org/geo/pdfs/Caribbean\\_EO\\_final.pdf](http://hqweb.unep.org/geo/pdfs/Caribbean_EO_final.pdf).*



## ◆ SECTION B - LIFE PROCESSES AND DISEASE

The life processes *will largely be illustrated* in humans and flowering plants because these are the two groups with which students are most familiar, and about which they should have some degree of understanding. **Comparisons with other organisms should be included where appropriate.** Details of anatomical structure are used to illustrate the relationships between structure and function.

There should be a focus on the interdependence of the *internal processes occurring at the organ and cellular levels* in maintaining the organism in a healthy state.

*Diseases common in the Caribbean variously affect the quality of life of its people, the efficiency of its human resources and its economy. The purpose of this aspect of the syllabus is to make students sufficiently aware of the problems and their implications so that they can recognise and deal with them in their own environments.*

### GENERAL OBJECTIVES

On completion of this Section, students should:

1. know the structure of an unspecialised cell (plant and animal) and appreciate the functions of the main cell structures and of cell specialisation;
2. understand that nutrition is the means by which living organisms obtain their energy and material requirements, and this occurs in different ways;
3. understand that respiration is the means by which energy is made available for carrying out life processes;
4. *understand the role of transport, storage and defense in living organisms;*
5. understand the processes by which living organisms get rid of metabolic waste and regulate body fluid concentration;
6. understand the mechanisms of movement and appreciate its role(s) in living organisms;
7. understand that organisms detect and respond to changes in their external and internal environment;
8. understand that organisms increase in mass, size and complexity during their lives;
9. understand the processes by which life is perpetuated;
10. *appreciate the social and economic importance of disease control in plants and animals.*

## SECTION B - LIFE PROCESSES AND DISEASE (cont'd)

SPECIFIC OBJECTIVES	CONTENT/EXPLANATORY NOTES	SUGGESTED PRACTICAL ACTIVITIES	SKILLS AND INTER-RELATIONSHIPS
Students should be able to:			
<b>1. Cells</b>			
1.1 <i>compare the structure of the generalised plant and animal cells, and selected microbes;</i>	Cell wall, cell membrane, nucleus, cytoplasm, vacuoles, mitochondrion, chloroplast. <i>Microbes to include bacterium, Protista, for example, amoeba. Simple structure of a bacterium to include nucleoid, cell wall, capsule and flagellum.</i>	Draw and label cells and cell structures from electron micrographs (mag.x2,000).	<i>Structure and function relationships</i>  <i>Skill: Dr.</i>
1.2 <i>distinguish between cell wall and cell membrane; mitochondrion and chloroplast;</i>		<i>Examine a variety of cells, for example, cells of Allium (purple onion), Rhoeo discolor, Elodea, prepared slides of blood cells, nerve cells and skin. Construct models using plasticine or other materials found around the home or laboratory.</i>	
1.3 <i>relate the structure of organelles to their functions;</i>	<i>Simple treatment of chloroplast; mitochondrion; vacuole; nucleus. For example, nucleus: chromosomes carry genetic information in the form of DNA. Refer SO C1.1</i>		Chemistry - DNA; proteins, chlorophyll; carbohydrates.
1.4 <i>differentiate between plant and animal cells;</i>	Reference to plant cells as characterised by the presence of a cell wall, large vacuoles and chloroplasts. Relate structure to function.		



## SECTION B - LIFE PROCESSES AND DISEASE (cont'd)

SPECIFIC OBJECTIVES	CONTENT/EXPLANATORY NOTES	SUGGESTED PRACTICAL ACTIVITIES	SKILLS AND INTER-RELATIONSHIPS
Students should be able to:			
1.5 <i>explain the importance of cell specialisation in multi-cellular organisms;</i>	<i>Examples of tissues from both plants and animals. Consideration that a number of different tissues (for example, epidermis, xylem, phloem) come together to form organs (leaf, stem) and organ systems (transpiration; translocation). Refer to SO B.4.7, 4.11.</i>	<i>Examine and draw the cross section of a stem or root as seen under the light microscope</i>	<i>Hierarchy of cells, tissues, organs; organ systems; organism; population; community, ecosystem. Refer to SO A2.2.  Skills: ORR; DR</i>
1.6 <i>explain the processes of diffusion and osmosis;</i>	<i>Importance of diffusion and osmosis in transporting substances in and out of cells and from one cell to another in all living organisms. Reference to the cell membrane as a differentially permeable membrane, contrast with cell wall which is freely permeable.</i>	<i>Carry out simple investigations to illustrate the movement of particles (molecules and ions). Identify everyday instances of these processes occurring.</i>	<i>Physics-Osmosis, diffusion. Chemistry-Particulate nature of matter; ions.  Skills: ORR; MM; AI.</i>
1.7 <i>discuss the importance of diffusion, osmosis and active transport in living systems.</i>	<i>Cite examples of each process occurring in living organisms. For example, diffusion across membrane of Amoeba, gas exchange across respiratory surfaces, absorption in small intestine, active uptake of mineral ions by plant roots.</i>		<i>Physics and Chemistry-Osmosis, diffusion.</i>
<b>2. Nutrition</b>			
2.1 <i>distinguish among heterotrophic, autotrophic and saprophytic nutrition;</i>	<i>Simple inorganic substances used by plants compared to complex organic substances consumed by animals and fungi. Refer to SO A2.7.</i>	<i>Identify sources of food for a named organism for each type of nutrition.</i>	<i>Chemistry-Water, nitrogen, carbon dioxide, starch, sugars, protein. Photosynthesis; respiration; decomposers. Energy relations.</i>



## SECTION B - LIFE PROCESSES AND DISEASE (cont'd)

SPECIFIC OBJECTIVES	CONTENT/EXPLANATORY NOTES	SUGGESTED PRACTICAL ACTIVITIES	SKILLS AND INTER-RELATIONSHIPS
Students should be able to:			
2.2 describe the process of photosynthesis in green plants;	<p>Simple treatment involving an equation to summarize the process;</p> <ul style="list-style-type: none"> <li>- the evolution of oxygen as a result of the splitting of water by light energy;</li> <li>- the subsequent reduction of carbon dioxide to a carbohydrate;</li> <li>- the chloroplast as the site of the reaction;</li> <li>- role of chlorophyll;</li> <li>- the fate of products (metabolised to provide energy or stored).</li> </ul>	<p>Test for evolution of oxygen using water plant. Carry out controlled experiments to demonstrate that light and chlorophyll are necessary for photosynthesis; Tests for end products, starch or reducing sugar.</p>	<p>Chemistry - Oxidation and reduction.</p> <p>Skills: ORR; MM.</p>
2.3 relate the structure of the leaf of a flowering plant to its function in photosynthesis;	<p>The external features and the internal structure of a dicotyledonous leaf as seen in cross section under the light microscope. Emphasise adaptations for photosynthesis (stomata; intercellular spaces; chloroplasts in palisade layer close to epidermis).</p>	<p>Draw and label the external features and internal structure of a dicotyledonous leaf as seen in cross section.</p>	<p>Role of water for opening of stomata; diffusion of CO<sub>2</sub>.</p> <p>Skills: ORR; Dr.</p>
2.4 explain how environmental factors affect the rate of photosynthesis;	<p>Use green and variegated leaves of hibiscus.</p>	<p>Investigations to include temperature, water and CO<sub>2</sub>.</p>	<p>Chemistry- Properties of some bio-molecules.</p> <p>Physics-Forms of energy, wavelengths of light; Fluorescent molecules.</p> <p>Skills: ORR; Dr; MM, PD.</p>



## SECTION B - LIFE PROCESSES AND DISEASE (cont'd)

SPECIFIC OBJECTIVES	CONTENT/EXPLANATORY NOTES	SUGGESTED PRACTICAL ACTIVITIES	SKILLS AND INTER-RELATIONSHIPS
Students should be able to:			
2.5 <i>discuss the importance of minerals in plant nutrition using nitrogen and magnesium as examples;</i>	<i>Emphasis on the importance of nitrogen in the formation of proteins and magnesium in the formation of chlorophyll.</i>	<i>Investigate the effect of the lack of nitrogen on seedlings.</i>	<i>Chemistry- Oxidation and reduction.  Skills: PD; ORR; MM; AI.</i>
2.6 <i>perform tests to distinguish among food substances;</i>	<i>Starch, protein, lipids, reducing and non-reducing sugars; chemical and physical properties (solubility) of carbohydrates, proteins, lipids; hydrolysis and condensation (dehydration synthesis).</i>	<i>Test for proteins (Biuret), fats (grease spot, ethanol – emulsion tests), starch (iodine), reducing sugars (Benedict’s solution). Note the necessity for hydrolysis and neutralisation in testing for non-reducing sugars.</i>	<i>Chemistry–Redox solubility, Organic Chemistry- condensation/hydrolysis.  Skills: ORR; MM.</i>
2.7 <i>relate the structures of the human alimentary canal to their functions;</i>	<i>Simple diagrams of the alimentary canal and internal structure of a tooth required.  Mastication and the role of teeth in the mechanical breakdown of food to be included.</i>		<i>Skill: Dr.</i>



## SECTION B - LIFE PROCESSES AND DISEASE (cont'd)

SPECIFIC OBJECTIVES	CONTENT/EXPLANATORY NOTES	SUGGESTED PRACTICAL ACTIVITIES	SKILLS AND INTER-RELATIONSHIPS
Students should be able to:			
2.8 <i>explain the role and importance of enzymes;</i>	<i>Inclusion of catalysis. Properties of enzymes, role of digestive enzymes in the mouth, stomach and pancreatic enzymes in the small intestine.</i>		<i>Chemistry - Rate of reaction, properties of proteins. Skills: ORR; MM; AI.</i>
2.9 <i>investigate the effect of temperature and pH on the activity of the enzymes catalase or amylase;</i>	<i>Candidates may be asked to deduce from tables and graphs the effects of temperature and pH on enzyme activity.</i>		<i>Chemistry-Acids and bases rate of reaction; Math - Simple graphs. Skills: ORR; MM; AI and PD.</i>
2.10 <i>describe what happens to the products of digestion after their absorption;</i>	<i>Simple diagram of villi and role in absorption of products of digestion. Transport to the liver and assimilation to be included, that is, how products are used and what happens to excess. Link to blood sugar control Refer to SO B5.2, 5.3</i>		<i>Homeostasis.</i>
2.11 <i>discuss the importance of a balanced diet in human.</i>	<i>Components of a balanced diet (including vitamins and minerals and their roles). The results of their deficiency or surplus (malnutrition). The effects of age, sex and occupation on dietary needs. Vegetarianism Dietary recommendations for treating and preventing named deficiency and physiological diseases – diabetes and hypertension.</i>		<i>Nutrition/Special diets.</i>



## SECTION B - LIFE PROCESSES AND DISEASE (cont'd)

SPECIFIC OBJECTIVES	CONTENT/EXPLANATORY NOTES	SUGGESTED PRACTICAL ACTIVITIES	SKILLS AND INTER-RELATIONSHIPS
Students should be able to:			
<b>3. Respiration</b>			
3.1 describe the process of aerobic respiration;	<p><i>Involvement of enzymes in releasing energy as ATP. Distinguish between respiration and breathing.</i></p> <p><i>Simple treatment. A chemical and word equation to show the starting materials and final products of aerobic respiration is required.</i></p>		<p><i>Chemistry- Endothermic and exothermic reactions. Physics - First and second law of thermodynamics.</i></p>
3.2 distinguish between aerobic and anaerobic respiration;	<p><i>Include the production of lactic acid in muscle, alcohol and carbon dioxide in plants, production of bio-gas from organic matter.</i></p>	<p><i>Simple investigations to show the products of anaerobic respiration in yeast.</i></p>	<p><i>Chemistry- Reactions involved in making bread and in vigorous exercise.</i></p> <p><i>Skills: MM; ORR; AI.</i></p>
3.3 describe the mechanism of breathing in humans and gaseous exchange in flowering plants;	<p><i>Simple diagrams to show the relationship between the trachea, the bronchi, alveoli and lungs and the diaphragm and ribcage required. The necessity for a continuous supply of oxygen and the removal of waste products to be included. Oxygen debt. Refer to SO B1.7, 3.2.</i></p>	<p><i>Use of model of the thorax.</i></p> <p><i>Note limitations.</i></p>	<p><i>Physics-Pressure, Diffusion.</i></p> <p><i>Skills: Dr, AI.</i></p>
3.4 identify characteristics common to gaseous exchange surfaces;	<p><i>Emphasis on mechanisms for increasing surface area in humans, fish and plants. Refer to SO B1.7.</i></p>	<p><i>Examine lungs of a mammal, gills of fish and various types of leaves.</i></p>	<p><i>Skill: Dr.</i></p>



## SECTION B - LIFE PROCESSES AND DISEASE (cont'd)

SPECIFIC OBJECTIVES	CONTENT/EXPLANATORY NOTES	SUGGESTED PRACTICAL ACTIVITIES	SKILLS AND INTER-RELATIONSHIPS
Students should be able to:			
3.5 <i>discuss the effects of smoking.</i>	<i>For example, nicotine addiction, damage to the lining of the lungs, cancer-causing effects and reduction in the oxygen carrying capacity of the blood. Marijuana addiction, acute chest illness, obstruction of airways (no further details required).</i>	<i>Interpret smoking data worldwide and for the Caribbean (cigarette use, death rates, cancer incidence).</i>	<i>Drug abuse and health.</i>
<b>4. Transport</b>			
4.1 explain the need for transport systems in multi-cellular organisms;	<i>The limitations of simple diffusion. Comparison with single celled organism such as the amoeba. The relationship between surface area and volume.</i>	<i>Make models, such as, cubes of different sizes and compare their surface area/volume ratio.</i>	<i>Chemistry-Diffusion Mathematics – Calculating area and volume.</i>
4.2 identify the materials which need to be transported in animals and plants;	<i>Oxygen, carbon dioxide, hormones, mineral nutrients, glucose and amino acids.</i>		
4.3 describe <i>the structure and function of the circulatory system in humans;</i>	<i>Structure and function of the heart. Names of blood vessels supplying lungs, kidney, liver, brain, intestine only.</i>	<i>Draw diagrams to show differences in the structures of arteries, veins and capillaries. Examine external and internal features of fresh or preserved specimens of mammalian hearts.</i>	<i>Skills: ORR; Dr.</i>



## SECTION B - LIFE PROCESSES AND DISEASE (cont'd)

SPECIFIC OBJECTIVES	CONTENT/ EXPLANATORY NOTES	SUGGESTED PRACTICAL ACTIVITIES	SKILLS AND INTER- RELATIONSHIPS
Students should be able to:			
4.4 relate the structure of the components of blood to their function;	Diagrams of red and white blood cells required.	<i>Use prepared slides only to show blood cells. Do not use fresh samples.</i>	<i>Skill: Dr.</i>
4.5 describe the role of blood in defending the body against disease;	<i>Include the clotting mechanism; the role of phagocytes and natural immunity.</i>		
4.6 explain how the principles of immunisation are used in the control of communicable diseases;	<i>As demonstrated by artificial immunity via vaccines. Refer to SO C5.4, 6.2.</i>		Antigen/antibody, variation, natural selection .
4.7 explain how the structure of xylem vessels is suited for their function;	Hollow tubes- non-living with lignified walls; no end walls- allow for a continuous flow of water.		<i>Physics-Cohesion, adhesion, tension.  Skill: Dr.</i>
4.8 discuss the role of the process of transpiration in plants;	<i>Transpiration stream from roots to leaves to be included. Refer to SO B4.2.</i>	<i>Observe small herbaceous plant placed in coloured water.</i>	
4.9 describe the effect of external factors on transpiration;	<i>Light intensity, temperature, humidity, and air movements should be included.</i>	<i>Carry out controlled investigations.</i>	<i>Skill: ORR.</i>
4.10 discuss adaption in plants to conserve water;	<i>Simple treatment of root length, cuticle thickness, water storage.</i>	<i>Observe succulent, xerophytic plants.</i>	
4.11 explain how the structure of the phloem is suited to its function;	Source ←-----→ Sink		<i>Translocation; storage organs; growing points. Formation of fruits/seeds; germination.</i>



## SECTION B - LIFE PROCESSES AND DISEASE (cont'd)

SPECIFIC OBJECTIVES	CONTENT/EXPLANATORY NOTES	SUGGESTED PRACTICAL ACTIVITIES	SKILLS AND INTER-RELATIONSHIPS
Students should be able to:			
4.12 identify the products stored in plants and animals and the sites of storage;	Roots, stems, leaves, fruits, seeds in plants; the liver, fat deposits in animals to be included. Detailed structure of storage organs not required.	<i>Carry out food tests for starch, sugars and oil in storage organs.</i>	<i>Chemistry-Sugar, starch, fats. Skills: MM, AI.</i>
4.13 discuss the importance of food storage in living organisms.	<i>Storage as a means of overcoming the need for continuous food intake or manufacture, providing for periods of scarcity, providing for special functions, such as, production of sexual or vegetative reproductive structures, development of embryos.</i>	<i>Draw and annotate stages in germinating seeds; Draw buds from plant storage organs (stems and tubers).</i>	<i>Physics-Energy. Chemistry- conversion of simple soluble substances to insoluble macromolecules. Skill: Dr.</i>
<b>5. Excretion</b>			
5.1 distinguish between egestion and excretion;	<i>Undigested material versus bilirubin in faeces, and urea in urine.</i>		<i>Metabolism.</i>
5.2 discuss the importance of excretion in living organisms;	<i>Implications of toxicity. For example, carbon dioxide, heat, urea, water, oxygen, calcium oxalate and tannins.</i>		<i>Chemistry- Oxygen, carbon dioxide, water.</i>
5.3 state how metabolic wastes are excreted from plants and animals;	<i>Leaf fall, loss of bark and storage in plants; lungs, skin, urinary systems in humans to be included.</i>		
5.4 relate the kidney to its osmoregulatory and excretory functions.	<i>Highlight structure of the urinary system and kidney tubule; The function of the parts. Mention kidney failure and dialysis. Role of ADH in homeostasis.</i>	<i>Annotated simple diagrams of the gross kidney structure and that of the nephron to illustrate the production of urine required.</i>	<i>Chemistry - Dialysis, Filtration contrast with Osmosis. Skill: Dr.</i>





## SECTION B - LIFE PROCESSES AND DISEASE (cont'd)

SPECIFIC OBJECTIVES	CONTENT/EXPLANATORY NOTES	SUGGESTED PRACTICAL ACTIVITIES	SKILLS AND INTER-RELATIONSHIPS
Students should be able to:			
<b>6. Movement</b>			
6.1 <i>distinguish between growth movements in plants and movement in animals;</i>	<p>The distinction should be made between:</p> <p>(a) growth movement as shown by germinating seedlings, Refer to SO B7.2 and B8.1.</p> <p>(c) <i>Locomotion/whole</i> movement as illustrated by animals.</p>	<i>Germinate peanuts or kidney beans or any appropriate seeds.</i>	<i>Skills: ORR; Dr; AI; MM.</i>
6.2 relate the structure of the skeleton to its function in humans;	Functions to include protection, support, locomotion, blood formation.	<i>Examine a human skeleton.</i>	<i>Physics-Centre of gravity.</i>
6.3 <i>discuss the importance of locomotion in animals;</i>	<i>Comparison with flowering plants; make reference to role in nutrition and reproduction.</i>		
6.4 <i>describe the mechanism of movement in a human fore limb.</i>	<p><i>The relationship between the bones and muscles of a limb. Behaviour of antagonistic muscles; types of joint, action at moveable joints.</i></p> <p><i>Draw, label and annotate a simple diagram of the long bone of a fore limb.</i></p>	<p><i>Simple line drawing to show the relationships. Note origin and insertion of muscles.</i></p>	<p><i>Physics- Moment of a force, efficiency levers.</i></p> <p><i>Skill: Dr.</i></p>

## SECTION B - LIFE PROCESSES AND DISEASE (cont'd)

SPECIFIC OBJECTIVES	CONTENT/EXPLANATORY NOTES	SUGGESTED PRACTICAL ACTIVITIES	SKILLS AND INTER-RELATIONSHIPS
Students should be able to:			
<b>7. Irritability</b>			
7.1 define 'stimulus' and 'response';			
7.2 describe the response of:			
(a) <i>green plants to stimuli;</i>	<i>The response of stems and roots of seedlings to light, touch and gravity. Relate observations to the behaviour of plants in natural situations. Refer to SO B6.1; 4.13.</i>	<i>Carry out controlled investigations; make observations; record and report as appropriate.</i>	<i>Physics - Light and gravity.</i>
	<i>Role of auxins not required.</i>		<i>Skills: ORR; PD; MM.</i>
(b) invertebrates to variations in light intensity, temperature and moisture;	<i>The response of invertebrates for example, millipedes, earthworms or woodlice.</i>	<i>Construct simple choice chambers. Record observations.</i>	
7.3 define receptor and effector;	Sense organs, muscle and glands. Leaf, petiole, apical meristem.	<i>Reaction to hot objects, insect bites.</i>	
7.4 explain why the response to stimuli is important for the survival of organisms;	Reference to investigations with green plants and invertebrates in SO B7.2.		<i>Skill: AI.</i>
7.5 explain the relationship among the receptor, the central nervous system and the effector;	Emphasis on the coordinating function of the brain and spinal cord and the roles of sensory and motor neurones.		

## SECTION B - LIFE PROCESSES AND DISEASE (cont'd)

SPECIFIC OBJECTIVES	CONTENT/EXPLANATORY NOTES	SUGGESTED PRACTICAL ACTIVITIES	SKILLS AND INTER-RELATIONSHIPS
Students should be able to:			
7.6 explain a simple reflex action;	<i>Use of simple flow diagrams to show the pathway along which the impulse travels in the reflex. Diagrams showing a spinal cord and spinal nerves not required.</i>	<i>Investigate changes in pupil size in response to changes in light intensity, using mirrors, or the knee jerk reflex.</i>	
7.7 describe the functions of the main regions of the brain;	Cerebrum, cerebellum and medulla.	<i>Use models and charts.</i>	
7.8 <i>discuss the physiological, social and economic effects of drug abuse;</i>	<i>Include alcohol and one illegal drug. Mention the use and abuse of prescription drugs, for example, diet pills, tranquilisers, steroids, caffeine and analgesics (pain-killers). Refer to SO B7.6, 7.7.</i>	<i>Research project. Research and interpret data on drug abuse in your territory.</i>	<i>Chemistry- Reactions of alcohol.  Skill: AI.</i>
7.9 relate the structure of the human eye to its functions as a sense organ;	Cross section or longitudinal section of the eye required. Role of rods and cones as specialized receptor cells. Refer to SO B1.5.	<i>Examine dissected eye of a mammal.</i>	<i>Physics-Lenses.</i>



## SECTION B - LIFE PROCESSES AND DISEASE (cont'd)

SPECIFIC OBJECTIVES	CONTENT/EXPLANATORY NOTES	SUGGESTED PRACTICAL ACTIVITIES	SKILLS AND INTER-RELATIONSHIPS
Students should be able to:			
7.10 explain accommodation; sight defects and <i>the</i> corrections of each;	Long and near sightedness; the use of corrective lenses; glaucoma.		<i>Physics –Light and image.</i>
7.11 <i>relate structure of the human skin to its function in temperature regulation and protection.</i>	Role of skin structures in temperature control as an example of homeostasis is required. <i>Refer to SO B 5.4.</i>  <i>Mention skin care and the effect of chemicals. The importance of melanin and SPF (simple treatment only). Discuss the skin bleaching phenomenon.</i>		<i>Skills: ORR; Dr.</i>
<b>8. Growth</b>			
8.1 make deductions from simple investigations designed to demonstrate growth in living organisms;	Examples could involve measuring changes in length, mass or surface area using roots, leaves, or other suitable material or counting the number of leaves in a named plant from seedling to fruiting plant. Include cell division in meristem; Comparison of growth in plants and animals.  Refer to Mitosis SO C4.2.	<i>Conduct simple exercise to investigate patterns of growth.</i>  <i>Draw and interpret graphs (growth curves, histograms) from given data.</i>	<i>Skills: ORR; Dr; MM, AI, PD.</i>
8.2 describe the structure of a dicotyledonous seed;	<i>Functions of the seed. Refer. S.O. B. 4.12; 4.13.</i>	<i>Draw, label and annotate the external and internal structures of a seed.</i>	<i>Skill: Dr.</i>

## SECTION B - LIFE PROCESSES AND DISEASE (cont'd)



SPECIFIC OBJECTIVES	CONTENT/EXPLANATORY NOTES	SUGGESTED PRACTICAL ACTIVITIES	SKILLS AND INTER-RELATIONSHIPS
Students should be able to:			
8.3 describe the processes taking place within a seed during germination.	Include breakdown of food stores and translocation to growing points. Refer To SO B4.12, 8.1.	<i>Use food tests to compare the food substances found in cotyledons before and after germination.</i>	<i>Chemistry-hydrolysis.</i>
<b>9. Reproduction</b>			
9.1 compare sexual and asexual reproduction;	Explanation that sexual reproduction leads to variation in the off-spring while asexual reproduction is conservative -offspring identical to the parent. Refer to SO C 4.2-4.6.		<i>Genetic variation.</i>
9.2 describe the structure and function of the reproductive systems in humans;	Male and female reproductive systems. Functions of the various parts.	<i>Label and annotate given diagrams.</i>	<i>Genetic variation and meiosis.</i>  <i>Skill: Dr.</i>
9.3 describe the menstrual cycle;	The roles of oestrogen and progesterone and the effect of pregnancy on the menstrual cycle to be included. Include pituitary/gonads.	<i>Use models, charts.</i>	
9.4 outline the mechanism for bringing gametes together, their fusion and the development of the embryo in humans;	Include implantation, functions of the amnion, placenta and umbilical cord.		
9.5 discuss the advantages and disadvantages of various methods of birth control;	For example, natural, barrier, hormonal and surgical methods. Consider social aspects.		

## SECTION B - LIFE PROCESSES AND DISEASE (cont'd)

SPECIFIC OBJECTIVES	CONTENT/EXPLANATORY NOTES	SUGGESTED PRACTICAL ACTIVITIES	SKILLS AND INTER-RELATIONSHIPS
Students should be able to:			
9.6 discuss the transmission and control of Acquired Immune Deficiency Syndrome (AIDS) and gonorrhoea;	Implications of sexually transmitted infections (STI's). Include causative agents. Mention prevention, treatment and control.	<i>Research and interpret Human Immunodeficiency Virus (HIV) incidence data in the Caribbean.</i>	<i>Genetic variation, mutations, natural selection, evolution.</i>
9.7 <i>relate the parts of a flower to their functions;</i>	Knowledge of: petals, sepals, anther, filament, stigma, style, ovary, ovules, embryo sac, micropyle and carpel required.	<i>Draw, label and annotate local specimens.</i>	<i>Skills: Dr; ORR.</i>
9.8 compare the structure of an insect pollinated flower and a wind pollinated flower;	Names of pollinating agents required.	<i>Examine and draw the various parts of an insect and wind pollinated flower.</i>	<i>Skills: ORR; Dr.</i>
9.9 <i>distinguish between the processes of pollination and fertilisation;</i>	Means by which male and female gametes are brought together and their fusion to form the zygote of a flowering plant. Include cross and self-pollination.		
9.10 <i>explain how fruit and seed formation occur after fertilization;</i>	Knowledge of the processes in dicotyledon plants only.		



## SECTION B - LIFE PROCESSES AND DISEASE (cont'd)

SPECIFIC OBJECTIVES	CONTENT/EXPLANATORY NOTES	SUGGESTED PRACTICAL ACTIVITIES	SKILLS AND INTER-RELATIONSHIPS
Students should be able to:			
<b>Disease</b>			
9.11 describe fruit structure including adaptations for fruit and seed dispersal.	At least one example of water, wind, mechanical and animal dispersal methods. Mention the importance of dispersal.	<i>Draw examples of fruits and seeds to show adaptations for dispersal.</i>	<i>Physics- Archimedes principle, density.</i>
10.1 distinguish among pathogenic, deficiency, hereditary and physiological diseases;	Include examples of each.		<i>Immunity; nutrition; genetics.</i>
10.2 identify the stages in the life cycle of a mosquito;	Include habitat and mode of life of each stage.	<i>Collect eggs and larvae of mosquitoes. Make observations and drawings of complete metamorphosis.</i>	<i>Skill: Dr.</i>
10.3 <i>discuss the role of the mosquito as a vector in the transmission of pathogenic diseases;</i>	Knowledge of malaria, dengue, yellow fever required.	<i>Collect and analyse data on the incidence of these diseases in the territory.</i>	
10.4 suggest appropriate methods of control of each stage of the life cycle of mosquito;	Refer to SO B10.2		
10.5 discuss the treatment and control of the four main groups of disease;	The role of diet and exercise in controlling physiological diseases: hypertension and diabetes to be included. Knowledge of insulin and glucagon required. Refer to SO B 2.11; 4.5; 9.6.		



## SECTION B - LIFE PROCESSES AND DISEASE (cont'd)

SPECIFIC OBJECTIVES	CONTENT/EXPLANATORY NOTES	SUGGESTED PRACTICAL ACTIVITIES	SKILLS AND INTER-RELATIONSHIPS
Students should be able to:			
10.6 discuss the social, environmental and economic implications of disease with reference to both plant and animal diseases.	Emphasize loss of productivity, loss of human life, livestock and agricultural crops. Refer to SO A7.1.	<i>Display and interpret statistical data from local examples.</i>	<i>Social Science.</i>

### **Suggested Teaching and Learning Activities**

*To facilitate students' attainment of the objectives of this Section, teachers are advised to engage students in the teaching and learning activities below. These activities are designed to promote inquiry-based learning and cater to students with various learning styles.*

- 1. Create a 3D model of a plant/animal cell OR write a first person narrative from the perspective of a particular type of cell, for example, "I'm Woody, the plant cell..."*
- 2. Carry out simple controlled investigations to monitor the growth of seedlings for a period of one month. Manipulate variables (for example, sunlight, water, nutrients, soil type), take measurements and report the findings.*
- 3. Visit the Malaria website from the [nobelprize.org](http://nobelprize.org) and play both the "Mosquito" and the "Parasite" games on the site. Familiarise yourself with the relationship between Plasmodium (the human parasite), the mosquito (the vector) and humans (the host). <http://nobelprize.org/educational/medicine/malaria/>.*
- 4. Work in groups to write short newspaper articles on the human body systems and the diseases that affect each (for example, the reproductive system – STIs, prostate cancer, cervical cancer).*
- 5. Interpret health data by investigating the number of persons in your country who suffer from diabetes and cancer. What are the causes, incidence rates and treatments available in your area?*
- 6. The Caribbean region is the most heavily affected by HIV/AIDs after Sub-Saharan Africa. Interpret HIV/AIDS data on the Caribbean as given by the United Nations. UNDP Report 2009. AIDS Epidemic Update. [http://data.unaids.org/pub/Report/2009/jc1700\\_epi\\_update\\_2009\\_en.pdf](http://data.unaids.org/pub/Report/2009/jc1700_epi_update_2009_en.pdf).*
- 7. Make educational flyers to post around your town to educate the public on facts and myths about HIV and other STIs.*
- 8. Compare the anatomy of an animal of your choice to the anatomy of a human.*
- 9. Create posters to highlight the structure and function of a body organ of your choice. The poster should be a creative in describing function associated, diseases and disorders, and whether a person can live without the organ.*





## ◆ SECTION C - CONTINUITY AND VARIATION

The teaching of Section C should highlight the implications of variation. The simple treatment of meiosis is deliberate; it is important that the consequences of the process be appreciated. Use of this knowledge for improved efficiency in agriculture should be considered.

*Note to Teacher: Biological evolution refers to genetic changes in the heritable traits in a population over multiple generations and is distinct from the origins or creation of Life. Scientists agree that evolution is the central-most concept in biology and provides a well-supported explanation for the biodiversity of life and how species adapt to new challenges. In particular, the treatment of evolution in the syllabus is of great importance to Small Island Developing States (SIDS) such as those found in the Caribbean. Our territories are faced with drastic changes due to human activity, overpopulation, limited resources, susceptibility to natural disasters, overfishing, deforestation and other pressures all of which pose a risk to the survival of species. Basic treatment of Biological evolution combined with genetics can enhance awareness and enable students to make more educated decisions regarding the environment. It is noteworthy to mention that in science the word “theory” is generally defined as an explanation that is firmly supported by evidence and widely accepted within the scientific community. Finally, the importance and applications of genetic variation and biological evolution in agriculture, healthcare, technology, and conservation should be noted.*

### GENERAL OBJECTIVES

On completion of this Section, students should:

1. *understand the “species” concept and the two major forms of speciation;*
2. *understand the importance of genetic variation in species;*
3. *understand the concept of the gene as it pertains to DNA, chromosomes and allele;*
4. *understand the role of genes and heredity in determining how traits can be altered and inherited by asexual and sexual means;*
5. *understand natural selection, mutation, gene flow, and genetic drift as mechanisms for biological evolution;*
6. *understand the evidence for biological evolution and the importance and applications of biological evolution in terms of healthcare, food technology, forensic science, and conservation biology;*
7. *appreciate the social and ethical implications of genetic engineering.*



## SECTION C - CONTINUITY AND VARIATION (cont'd)

SPECIFIC OBJECTIVES	CONTENT/EXPLANATORY NOTES	SUGGESTED PRACTICAL ACTIVITIES	SKILLS AND INTER-RELATIONSHIPS
Students should be able to:			
1.1 distinguish among DNA, chromosomes, genes and alleles;	<p>DNA (deoxyribonucleic acid) as nucleic acid that contain all genetic information. Gene as a portion/segment of DNA that carries information to produce a specific protein. Chromosome as DNA and protein (histones). Haploid as the 'n' number of chromosomes. Diploid as the '2n' number of chromosomes. Alleles as two or multiple forms of the same gene.</p>	Construct models of the structure of DNA and chromosomes.	Relationships between gene; allele; DNA; chromosome protein.
2.1 describe the process of mitosis;	<p>Emphasis on its importance for maintaining species chromosome number. Mention the replication of chromosomes. Names of stages are not required. Refer to SO B9.1.</p>	Construct models.	Skill: Dr. Significance of mitosis in growth and asexual reproduction.
2.2 explain the role of mitosis in asexual reproduction;	<p>Include at least two examples of asexual reproduction in plants such as sugarcane cuttings and Bryophyllum leaves.</p>		Genetic variation - Genotype maintained.
2.3 explain why asexual reproduction gives rise to genetically identical offspring;	<p>Cloning as the reproduction of populations of genetically identical individuals.</p>		Tissue culture, Human cloning. Ethical issues.

## SECTION C - CONTINUITY AND VARIATION (cont'd)

SPECIFIC OBJECTIVES	CONTENT/EXPLANATORY NOTES	SUGGESTED PRACTICAL ACTIVITIES	SKILLS AND INTER-RELATIONSHIPS
Students should be able to:			
2.4 describe the process of meiosis;	Simple treatment to include only homologous pairs, crossing over, separation of homologous chromosomes and subsequent separation of chromatids. Names of stages not required.	Construct models.	Formation of gametes (pollen; ovule; ovum; sperms).
2.5 state the importance of halving of chromosome number in the formation of gametes;			
2.6 explain the role of meiosis in the transmission of inheritable genetic characteristics;	Role of crossing over random assortment and recombination in genetic variation (benefits of sexual reproduction).		
2.7 explain the meaning of the following terms: dominant trait, recessive trait, codominance, genotype, phenotype, homozygous and heterozygous;	Codominance: blood group inheritance in humans.		
2.8 explain the inheritance of traits (dominant and recessive genes);	Examples to include Sickle cell anaemia, and albinism. Genetic diagrams required.		

## SECTION C - CONTINUITY AND VARIATION (cont'd)

SPECIFIC OBJECTIVES	CONTENT/EXPLANATORY NOTES	SUGGESTED PRACTICAL ACTIVITIES	SKILLS AND INTER-RELATIONSHIPS
Students should be able to:			
2.9 <i>predict the results of crosses involving one pair of alleles in the heterozygous, homozygous dominant and recessive conditions;</i>	<i>Include Punnet squares and pedigree charts to show dominant, recessive and co-dominant traits. Include genotypic and phenotypic ratios. Students should be able to identify the various phenotypic ratios obtained from crossing homozygous and heterozygous parental genotypes.</i>		
2.10 <i>describe the mechanism of sex determination and inheritance of sex linked diseases in humans;</i>	<i>Include example of sex linked disease such as haemophilia and colour blindness.</i>		
3.1 <i>explain how genetic variation arises;</i>	<i>Sexual reproduction; mutation.</i>		
3.2 <i>explain why genetic variation is important;</i>	<i>Variation makes it less likely that a change in environmental conditions will wipe out an entire species.</i>	<i>Observe and record plant and animal variations in your community, for example, hibiscus flowers, frogs, fishes, birds. Stress variations within a species, for example, humans and tomatoes.</i>	<i>Adaptation.</i>



## SECTION C - CONTINUITY AND VARIATION (cont'd)

SPECIFIC OBJECTIVES	CONTENT/EXPLANATORY NOTES	SUGGESTED PRACTICAL ACTIVITIES	SKILLS AND INTER-RELATIONSHIPS
Students should be able to:			
3.3 <i>distinguish between continuous and discontinuous variation in populations;</i>	<i>Example: foot size, presence or absence of horns in cattle, pod size, tongue rolling, and leaf size. Mention genetic and environmental effects.</i>	<i>Carry out a survey on appropriate characteristics; for example, observe and record the range of variation in a particular feature of any kind of organism.</i>	<i>Skills: ORR; PD; AI.</i>
4.1 <i>define a species;</i>	<i>Include biological species concept (group of closely related organisms that are able to interbreed and produce fertile offspring). Give examples of species of birds, plants that can interbreed. When two unrelated species mate, their offspring are not viable or if survive will be infertile, for example, the mule. Refer to SO A2.1, 2.2.</i>		
4.2 <i>describe how new species are formed;</i>	<i>Two types: -Speciation caused by physical geographic separation such as a river forming, colonizing a new island or rise of a mountain range (occurs with loss of habitat or the formation of new habitat); -Speciation caused by ecological and behavioral differences such as courtship behaviour/ differences in coloration. Note: Over time, species can also go extinct due to hunting/habitat loss/disease, for example, Caribbean Monk Seal.</i>	<i>Make drawings to depict both types of speciation mechanisms.</i>	



## SECTION C - CONTINUITY AND VARIATION (cont'd)

SPECIFIC OBJECTIVES	CONTENT/EXPLANATORY NOTES	SUGGESTED PRACTICAL ACTIVITIES	SKILLS AND INTER-RELATIONSHIPS
Students should be able to:			
5.1 explain how natural selection plays a role in biological evolution;	<p><i>Natural selection as a process by which a population retains those genes which makes it adapted to its habitat. Natural selection normally preserves useful adaptations. Relate genetic variation to natural selection (variation provides the template for natural selection to act on).</i></p> <p><i>Mutation.</i></p> <p><i>The peppered moth, the Galapagos finches, bacterial resistance to antibiotics, pesticide resistance; the radiation of the Caribbean lizards. Use other local examples. For example, flower coloration: If a goat is attracted to red flowers and eats 75% of red flowers compared to the pink flowers in population, it acts as the selective force that leads to changes in the overall genetic diversity of the plant population.</i></p>	<p><i>Research how natural selection has played a role in the evolution of cassava plants, sea turtles, and Caribbean lizards.</i></p>	
5.2 distinguish between natural and artificial selection;	<p><i>Mention plant and animal breeding. Humans select traits to suit their needs. Cite local examples.</i></p>		<i>Agricultural Science</i>

## SECTION C - CONTINUITY AND VARIATION (cont'd)

SPECIFIC OBJECTIVES	CONTENT/EXPLANATORY NOTES	SUGGESTED PRACTICAL ACTIVITIES	SKILLS AND INTER-RELATIONSHIPS
Students should be able to:			
6.1 describe how genetic engineering can be used to change the traits of an organism;	Changing the traits of one organism by inserting genetic material from a different organism. <i>Include food production and medical treatment. For example, insulin production and incorporation of beta carotene producing gene in rice for areas that are affected by night blindness.</i> Refer to SO B2.11; B7.3.		<i>Agriculture and medicine.</i>
6.2 discuss the possible advantages and disadvantages of genetic engineering.	<i>Social, ethical and ecological implications; Fingerprinting, DNA tests, gene therapy, captive breeding programmes.</i>		

### **Suggested Teaching and Learning Activities**

To facilitate students' attainment of the objectives of this Section, teachers are advised to engage students in the teaching and learning activities below. These activities are designed to promote inquiry-based learning and cater to students with various learning styles.

1. Create a comic book that gives life to the following terms: DNA, chromosome, gene, allele, haploid, diploid, dominant, recessive, co dominance, genotype, and phenotype.
2. Take a trip to your local zoo or aquarium to identify local examples of biodiversity in the Caribbean. Discuss why genetic variation is important.
3. Discover the truth about and importance of Natural Selection. Navigate through the University of California at Berkeley's site on natural selection, natural selection at work, misconceptions about natural selection, mutations, genetic variation, adaptation and artificial selection. [http://evolution.berkeley.edu/evolibrary/article/evo\\_25](http://evolution.berkeley.edu/evolibrary/article/evo_25).
4. The Caribbean is regarded as one of the world's biodiversity "hotspots" (Myers et al. 2000). Interpret data on Biodiversity in the Caribbean presented in pages 51-56 in the Caribbean Environmental Outlook; [http://hqweb.unep.org/qeo/pdfs/Caribbean\\_EO\\_final.pdf](http://hqweb.unep.org/qeo/pdfs/Caribbean_EO_final.pdf). Make a collage showcasing the biodiversity in your country.



## SECTION C - CONTINUITY AND VARIATION (cont'd)

5. *Diversity and adaptations of organisms. Write a research paper on the evolution of domestic dogs from wolves. Video Resources: <http://www.pbs.org/wnet/nature/lessons/from-wolf-to-dog/video-segments-dogs-that-changed-the-world/4800/>*
6. *Critical thinking problem: A few of months ago, the shed in Mr. Farmer's backyard suddenly became infested with flies. It was sprayed with a solution of insecticide, which killed nearly all the flies. However, sometime later, the numbers of flies increased again. The spraying process with the insecticide was repeated five (5) times, but it was clear that every time spraying was done, the insecticide became less and less effective in killing the flies. Write a short explanation for these observations.*
7. *Research some of the species in the Caribbean are gone extinct (for example, Caribbean Monk Seal, Giant tortoises (*Geochelone spp*), and some primates). What caused the extinction of these species?*
8. *Write a one-page plea from the viewpoint of an endangered species in your country. Why is this species important and why should it be protected?*
9. *Research the role of natural selection in the evolution of Cassava plants, Sea Turtles, Green Monkeys and Caribbean Lizards in the Caribbean. Summarise the findings on one page.*





## ◆ GUIDELINES FOR THE SCHOOL-BASED ASSESSMENT

### RATIONALE

School-Based Assessment (SBA) is an integral part of student assessment in the course covered by this syllabus. It is intended to assist students in acquiring certain knowledge, skills and attitudes that are critical to the subject. The activities for the School-Based Assessment are linked to the “Suggested Practical Activities” and should form part of the learning activities to enable the student to achieve the objectives of the syllabus.

During the course of study of the subject, students obtain marks for the competencies they develop and demonstrate in undertaking their SBA assignments. These marks contribute to the final marks and grades that are awarded to students for their performance in the examination.

The guidelines provided in this syllabus for selecting appropriate tasks are intended to assist teachers and students in selecting assignments that are valid for the purpose of the SBA. These guidelines are also intended to assist teachers in awarding marks according to the degree of achievement in the SBA component of the course. In order to ensure that the scores awarded by teachers are not out of line with the CXC standards, the Council undertakes the moderation of a sample of SBA assignments marked by each teacher.

School-Based Assessment provides an opportunity to individualise a part of the curriculum to meet the needs of students. It facilitates feedback to the students at various stages of the experience. This helps to build the self-confidence of the students as they proceed with their studies. School-Based Assessment further facilitates the development of critical skills and that allows the students to function more effectively in their chosen vocation and in everyday life. School-Based Assessment therefore, makes a significant and unique contribution to the development of relevant skills by the students. It also provides an instrument for testing them and rewarding them for their achievements.

### PROCEDURES FOR CONDUCTING SBA

**SBA assessments should be made in the context of normal practical coursework exercises.** It is expected that the exercises would provide authentic learning experiences. Assessments should only be made after candidates have been taught the skills and given enough opportunity to develop them. **Eighteen** practicals over the two-year period would be considered the minimum number for candidates to develop their skills and on which to base realistic assessments. **These practicals MUST include all of the following:**

1. *Ecological study.*
2. *Movement at molecular level (diffusion, osmosis).*
3. *Photosynthesis/respiration.*
4. *Food tests.*
5. *Germination.*
6. *Nutrition and diseases.*
7. *Genetics*



Each skill with the exception of Drawing must be assessed **at least two times** over the two-year period. Candidates should be encouraged to do corrections so that misconceptions will not persist. As the assessments of certain skills, especially those requiring on-the-spot observation, involve looking at several behaviours or criteria, teachers are advised to select not more than two skills to be assessed in any activity. The practical exercises selected to be used for assessment should make adequate demands on the candidates and the skills assessed should be appropriate for the exercises done. For the assessment of written work, the practical selected should be one that can be completed in the time allotted for the class and the notebooks should be collected at the end of the period.

Candidates who have not been assessed over the two-year period will be deemed absent from the whole examination. Under special circumstances, candidates who have not been assessed at all points may, at the discretion of CXC, have their marks pro-rated (adjusted proportionately).

**1. In preparation for an SBA practical, the teacher should:**

- (a) select tasks which must include the **seven (7)** topics on page 45 and should be related to a given syllabus objective. These tasks may be chosen from the “Suggested Practical Activities” and should fit in with the normal work being done in that class;
- (b) list the materials including quantities and equipment that will be needed for each student;
- (c) carry out the experiment beforehand, if possible, to ascertain the suitability of materials and the kind of results (observations, readings) which will be obtained, noting especially any unusual or unexpected results;
- (d) list the steps which will be required by the candidates in performing the experiment. From this it will be clear to the teacher how the candidates should be arranged in the laboratory, whether any sharing of equipment or materials is necessary, the skills which can be assessed from the practical, and the instructions to be given;
- (e) list the skills that may be assessed (for example, observation/recording/reporting, analysis and interpretation). **No more than two practical skills should be assessed from any one activity;**
- (f) select the skills to be assessed on this occasion. Skills other than those required for that year should also be included for teaching purposes;
- (g) work out the criteria for assessing each skill. This will form the basis of a mark scheme and a checklist.

**2. The teacher should carry out the assessment and record the marks.**

This is the most critical step in the assessment process. For a teacher to produce marks that are reliable, the marking must be consistent for all candidates and the marks should reflect the standard of performance at the level. The teacher must be able to justify the marks, and this occurs when there is a fixed set of conditions, factors or criteria for which the teacher looks. Marks should be submitted electronically to CXC using the SBA form provided. *The forms should be dispatched through the Local Registrar by the Moderator to reach CXC by 30 April of the year of the examination.*



## ASSESSMENT OF PRACTICAL SKILLS

School-Based Assessment will assess skills under the profiles Experimental Skills and Use of Knowledge (Analysis and Interpretation only).

The assessment will be conducted during Terms 1 - 5 of the two-year period following the programme indicated in the Table below.

### SBA SKILLS TO BE ASSESSED FOR CXC MODERATION

PROFILE	SKILLS	YEAR 1		YEAR 2		MARKS	
		NO. OF TIMES SKILLS TO BE ASSESSED	MARKS	NO. OF TIMES SKILLS TO BE ASSESSED	MARKS		
XS	Manipulation/ Measurement	1	10	1	10	20	70  (30*)
	Observation/ Recording/ Reporting	1	10	1	10	20	
	Planning and Designing	1	10	1	10	20	
	Drawing	1	10	-	-	10	
UK	Analysis and Interpretation	1	10	1	10	20	20  (10*)
	<b>TOTAL</b>	5	50	4	40	90	40*

**\*Weighted mark**

#### Investigative project to be done in Year 2

The investigative project would be assessed for two skills, Planning and Designing and Analysis and Interpretation.

**Students who are pursuing two or more of the single science subjects (Biology, Chemistry, and Physics) may opt to carry out ONE investigation only from any of these subjects.**



## ASSESSMENT OF INVESTIGATION SKILLS

### Proposal (Planning and Design)

The maximum marks available for the Proposal is

**10 marks**

The format for this part outlined below:

Observation/Problem/Research question stated	
Hypothesis	2 marks
Aim	1 mark
Materials and Apparatus	1 mark
Method	2 marks
Controlled variable	1 mark
Expected Results	2 marks
Assumptions, Precautions/Sources of error/Limitations	1 mark

**TOTAL**

**10 marks**

### Implementation (Analysis and Interpretation)

The maximum marks available for the Implementation

**20 marks**

The format for this part is shown below:

Method	1 mark
Results	4 marks
Discussion	5 marks
Limitation	3 marks
Reflection	5 marks
Conclusion	2 marks

**TOTAL**

**20 marks**

## REPORTING FORMAT OF INVESTIGATION

### **PART A THE PROPOSAL (Planning and Design)**

**Statement of the Problem** – Can be an observation, a problem

**Hypothesis**

**Aim** – Should be related to the hypothesis

**Materials and Apparatus**

**Method** – Should also include variables

Assumptions/Precautions/Possible sources of errors

Expected Results

### **PART B THE IMPLEMENTATION (Analysis and Interpretation)**

**Introduction** – Background to the problem

**Method** - Linked to Part A (change of tense)

**Results**

**Discussion** – Explanations/Interpretations/Trends

**Limitations**

**Reflections**

**Conclusion**



## ASSESSMENT OF INVESTIGATIVE SKILLS

<b>A. PLANNING AND DESIGN</b>		<b>TOTAL (10)</b>
<b>HYPOTHESIS</b>		<b>2</b>
- Clearly stated	1	
- Testable	1	
<b>AIM</b>		<b>1</b>
- Related to hypothesis	1	
<b>MATERIALS AND APPARATUS</b>		<b>1</b>
- Appropriate materials and apparatus	1	
<b>METHOD</b>		<b>2</b>
- Suitable	1	
- At least one manipulated or responding variable	1	
<b>CONTROLLED VARIABLE</b>		<b>1</b>
- Controlled variable stated	1	
<b>EXPECTED RESULTS</b>		<b>2</b>
- Reasonable	1	
- Link with method	1	
<b>ASSUMPTIONS/PRECAUTIONS/POSSIBLE SOURCES OF ERRORS</b>		<b>1</b>
- Any one stated	1	
<b>B. ANALYSIS AND INTERPRETATION</b>		
<b>METHOD</b>		<b>1</b>
Linked to Proposal, Change of tense		
<b>RESULTS</b>		<b>4</b>
- Correct formulae and equations:	2	
Accurate (2)		
Acceptable (1)		
- Accuracy of data:	2	
Accurate (2)		
Acceptable (1)		
<b>DISCUSSION</b>		<b>5</b>
- Explanation	2	
Development of points:		
Thorough (2)		
Partial(1)		
- Interpretation	2	
Fully supported by data (2)		
Partially supported by data (1)		
- Trends	1	
Stated		



**LIMITATIONS** **3**

- Sources of error identified 1
- Precautions stated 1
- Limitation stated 1

**REFLECTIONS** **5**

- *Relevance between the experiment and real life (Self, Society or Environment)* 1
  
- *Impact of knowledge gain from experiment on self* 1
- *Justification for any adjustment made during experiment* 2
- *Communication of information*  
(Use of appropriate scientific language, grammar and clarity of expression all of the time (2); some of the time (1))

**CONCLUSION** **2**

- *Stated* 1
- *Related to the aim* 1

**TOTAL** **(20)**

(Scale down to 10 marks)

## EXEMPLAR OF INVESTIGATIVE PRACTICAL

### EXEMPLAR 1

#### PART A-THE PROPOSAL

##### Observation

Ten year old John observed that after his grandfather planted some bean seedlings, he immediately applied a blue liquid to them which he had carefully measured out into the watering can. He asked his older sibling what was the blue liquid their grandfather applied to the seedlings and why did he measure it.

##### Hypothesis

Increasing the concentration of fertilizer applied to bean seedlings increases the number of leaves produced in the bean seedlings.

**Aim:** To determine if increasing the concentration of artificial fertilizer increases the number of leaves produced in the bean seedlings.

**Materials:** Clean washed sand, distilled water, 5 beakers, red beans, 5 plastic trays of the same dimensions, foil trays, 4 measuring cylinders, a liquid fertilizer.

##### Method

All apparatus will be cleaned and dried before beginning the experiment.

The four trays will be labelled as follows: no fertilizer,  $\frac{3}{4}$  strength,  $\frac{1}{2}$  strength,  $\frac{1}{4}$  strength.

Take the fertilizer and make it up to full strength following the manufacturer's instructions. Make up to one litre. Label this full strength.

Make up dilute solutions of the fertilizer as follows.

Measure out 150 ml of the full strength into a beaker. Using a measuring cylinder measure 50 ml of distilled water and add to the beaker. Label this  $\frac{3}{4}$  strength.

Measure out 100 ml of the full strength into a beaker. Using a measuring cylinder measure 100 ml of distilled water and add to the beaker. Label this  $\frac{1}{2}$  strength.

Measure out 50 ml of the full strength into a beaker. Using a measuring cylinder measure 150 ml of distilled water and add to the beaker. Label this  $\frac{1}{4}$  strength.

Fill the trays with the washed dried sand. In each tray plant four (4) beans. Each bean should be planted no more than 1 cm below the surface and should be spaced as far away from each other as the container allows.

Saturate the soils in the tray labelled no fertilizer, by adding measured amounts of distilled water until sand is moist. Add the same volume of distilled water to each of the other trays.

To tray labelled no fertilizer add 15 ml of distilled water. To tray labelled full strength measure out 15 ml



and add to tray labelled full strength. Repeat the procedure for the remaining trays. Repeat the addition of the 15 ml of liquid to the appropriately labelled tray for the next ten days. Ensure that the solution is added the same time each day.

Place trays in a bright, well-ventilated area. Observe the trays each day. Record the day on which the beans germinated. Count the number of leaves on each seedling and record in a table. Observations such as the colour of the leaves and stem and the size of leaves can also be recorded.

### **Expected results**

It is expected that the tray containing the full strength fertilizer would have the greatest number of leaves, followed by the  $\frac{3}{4}$  strength, the  $\frac{1}{2}$  strength and the  $\frac{1}{4}$  strength. The tray containing no fertilizer should have the least number of leaves.

## **PART B- THE IMPLEMENTATION**

### **Introduction**

Plants take up water and mineral salts from the soil. The mineral salts are required to ensure proper growth of plants. Nitrates, phosphates, potassium, iron, calcium and sulfate are some of the minerals required and they can be found in artificial fertilizers but must be applied in the amounts required by the plant.

The number of leaves produced by seedlings in a given time, changes in length, mass and surface area can be used to demonstrate growth in plants.

In this experiment the relationship between the quantity of fertilizer added and the growth rate of the seedlings will be explored.

### **Method**

All apparatus was cleaned and dried before beginning the experiment.

The four trays were labelled:

1. no fertilizer;
2.  $\frac{3}{4}$  strength;
3.  $\frac{1}{2}$  strength; and
4.  $\frac{1}{4}$  strength.

The fertilizer was collected and made up to full strength following the manufacturer's instructions. 500 ml of solution was made up. This was labelled full strength.

Dilute solutions of the fertilizer were made up as follows:

1. 150 ml of the full strength was measured out and poured into a beaker. Using a measuring cylinder;
2. 50 ml of distilled water was measured out and added to the beaker. This beaker was labelled  $\frac{3}{4}$  strength;
3. 100 ml of the full strength was measured out and poured into a beaker. Using a measuring cylinder 100 ml of distilled water was measured out and added to the beaker. This beaker was labelled  $\frac{1}{2}$  strength;





4. 50 ml of the full strength was measured out and poured into a beaker. Using a measuring cylinder 150 ml of distilled water was measured out and added to the beaker. This beaker was labelled  $\frac{1}{4}$  strength.

The trays were filled with the washed dried sand. In each tray four (4) beans were planted. Each bean was planted no more than 1 cm below the surface and were be spaced as far away from each other as the container allowed.

The sand in the tray labelled no fertilizer was saturated with distilled water, by adding measured amounts of distilled water until sand was moist. The same volume of distilled water was added to each of the other trays.

To tray labelled no fertilizer 15 ml of distilled water was added. To tray labelled full strength 15 ml of the full strength solution was measured out and added to tray. The procedure was repeated for the remaining trays.

The addition of the 15 ml of liquid to the appropriately labelled tray was repeated for the next ten days. The solution was added the same time each day.

Trays were placed in bright, well-ventilated area. The tray was observed each day. The day on which the beans germinated was recorded. At the end of ten days the number of leaves on each seedling was counted and recorded in a table. Observations such as the colour of the leaves and stem and the size of leaves were also be recorded.

## **Results**

**TABLE SHOWING THE EFFECT OF VARIOUS CONCENTRATIONS OF FERTILIZER ON THE GROWTH OF BEAN SEEDLINGS**

<b>Tray</b>	<b>Total number of leaves after 10 days</b>	<b>Additional observations</b>
<b>No fertilizer</b>	18	Leaves were small and yellow. Stems were also yellow and were shortest.
<b>Full strength</b>	45	Leaves were large and dark green. Stems were also green and were the tallest.
<b><math>\frac{3}{4}</math> strength</b>	33	Leaves were larger than those in the tray with $\frac{1}{2}$ strength fertilizer but smaller than full strength. Stems were greener and taller than those in the tray with $\frac{1}{2}$ strength, $\frac{1}{4}$ strength and no fertilizer
<b><math>\frac{1}{2}</math> strength</b>	27	Leaves were larger than those in the tray with $\frac{1}{4}$ strength fertilizer but smaller than $\frac{3}{4}$ strength. Stems were greener and taller than those in the tray with $\frac{1}{4}$ strength and no fertilizer.
<b><math>\frac{1}{4}</math> strength</b>	22	Leaves were larger than those in the tray with no fertilizer but smaller than $\frac{1}{2}$ strength. Stems were greener and taller than those in the tray with no fertilizer

## **Discussion**

Plants need the minerals to provide the elements needed to make constituents such as proteins, DNA, chlorophyll and cellulose. Magnesium is an important part of the chlorophyll molecule, required by the



plant to photosynthesize. In the absence of magnesium and hence, chlorophyll leaves are yellow and smaller. Nitrates are required to make amino acids and proteins and DNA. If it is absent, the plant is stunted and the leaves are fewer in number and smaller.

Other minerals such as phosphates, potassium, iron, calcium and sulfate are also required for making DNA, parts of cell membranes, and enzymes for respiration and photosynthesis. In the absence of these chemicals plant growth is slowed, the numbers of leaves produced and the size of these leaves is lessened.

These chemicals are required in specific amounts and that is why when using artificial fertilizers that they must be applied in the amounts suggested by the manufacturer. Too much fertilizer can also have a negative effect on the growth of the seedlings but this was not investigated in this experiment.

Therefore, it is clear that increasing the concentration of fertilizer applied to bean seedlings increases the number of leaves produced in the bean seedlings. The seedlings have taller, greener stems, with more leaves which are larger and greener.

### **Conclusion**

Increasing the concentration of fertilizer applied to bean seedlings increases the number of leaves produced in the bean seedlings.

### **Limitations**

Every effort was made to reduce experimental error as much as possible. All conditions were kept constant. However, the following may have contributed to experimental error:

1. Whether all four beans in each tray germinated and continued to grow for the ten days of the experiment;
2. Whether the volumes of fertilizer added each day was enough provide the appropriate amounts of minerals required for growth for the ten days and contained enough water to compensate for the water loss due to evaporation.

### **Reflections**

From this investigation, I have a greater appreciation for the importance of minerals for plant growth. I also recognise the importance of following the manufacturer's instructions. I can now appreciate why farmers add fertilizers to increase the yield of the produce and why fertilizers are heavily used in countries/lands where the soils are not very fertile. I also learnt why the production of fertilizer is a billion dollar industry.

This practical is based on Section B Life Processes and Disease, Nutrition, Specific Objectives 2.5 and Growth Specific Objective 8.1

Please note that the demands of the practical can be adjusted depending on the capabilities of the class and the equipment/apparatus available at the school. Instead of counting the number of leaves students could:

1. measure the height of the four stems daily and calculate the average daily height for the four beans for each tray. A graph of average height against day number could be plotted for each tray on the same graph;



2. tag leaves and measure their surface area each day on square paper. The average surface area of the leaves for the four bean seedlings for each tray can be calculated and a graph plotted;
3. histograms could be plotted instead of line graphs;
4. germinate more beans using larger trays and calculate the dry mass daily for each tray. A graph can be plotted once again.

## EXEMPLAR 2

### Part A - THE PROPOSAL

#### Observation

Mary noticed several similarities and differences among her classmates but was particularly intrigued with the variation in earlobes. Some of her classmates had free hanging earlobes while some had attached earlobes. These observations led her to wonder about the general pattern of inheritance of this trait and how this trait is passed from parents to offspring.

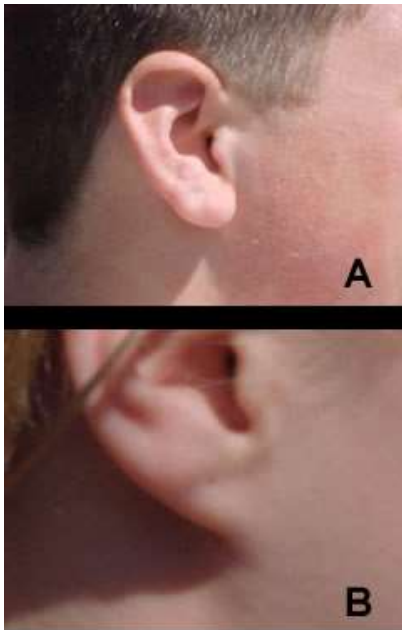

A. Free hanging earlobes

B. Attached earlobes

[http://www.windows2universe.org/earth/Life/genetics\\_puzzle.html](http://www.windows2universe.org/earth/Life/genetics_puzzle.html)

**Hypothesis:** Students with free hanging earlobes will have both parents with free hanging earlobes, while students with attached earlobes will have both parents with attached earlobes.

**Aim:** To investigate the pattern of inheritance for free hanging earlobes versus attached earlobes using data from classmates, their siblings and their parents.

**Materials:** paper; pencil; clip-board.

#### Method

1. Separate the class into two groups: those with free hanging earlobes and those with attached earlobes.



2. Record the presence or absence of free hanging earlobes versus attached earlobes for yourself, your siblings and your parents.
3. Select five additional classmates at random (if you have free hanging earlobes, select two (2) classmates from the “free hanging earlobes group” and three (3) from the “attached earlobes group”. If you have attached earlobes, select two (2) classmates from the “attached earlobes group” and three (3) from the “free hanging earlobes group”). Obtain earlobe information for them as well as their siblings and both of their parents.
4. Record the earlobe information for all six (6) students (include yourself), and their siblings and parents in a table.
5. Analyze the phenotypic information for both groups, assuming that the genes for this characteristic are inherited according to Mendelian genetics. Answer the following questions:
  - (a) Did all students with free hanging earlobes have both parents and all siblings with free hanging earlobes?
  - (b) Did all students with attached earlobes have both parents and all siblings with attached earlobes?
  - (c) Assign genotypes to the parents and use Punnet squares and Mendelian genetics to predict the genotypes of the offspring (students and their siblings). Based on your analysis, are free hanging earlobes a dominant or recessive trait? Why or why not?

### **Expected Results**

It is expected that students with free hanging earlobes will have both parents with free hanging earlobes and all sibling will free hanging earlobes. The same pattern is expected for those students with attached earlobes.

The critical analysis of this study will involve determining the genotype of the students, children and parents based on the phenotypes observed.

## **PART B- IMPLEMENTATION**

### **Introduction**

Genes control the physical appearance of an organism. Genotype represents the hereditary information or exact genetic makeup of an organism for a particular trait. The phenotype is the actual observed property resulting from the expression of those genes as a physical characteristic (For example, free hanging versus attached earlobes). For diploid organisms of which humans are an example, every gene comes in two copies or alternate forms known as alleles, one, which comes from the mother, and one, which comes from the father. The combination of these two alleles is called the genotype and it is this combination that controls our physical characteristics (phenotypes). The common means to express genotypes is to use a capital letter “E” for a dominant allele and a lower case letter “e” to represent a recessive allele.

Some physical traits are considered discrete traits because they are governed by one set of genes. The expression of those traits depends on whether the genotype is homozygous dominant (EE), heterozygous (Ee) or homozygous recessive (ee). In this experiment, the distribution and inheritance of those two discrete traits will be investigated. It will be assumed that only one pair of genes controls the traits free hanging versus attached earlobes and that this gene is inherited according to Mendelian Genetics.



## **Method**

1. The class was separated into two groups: those with free hanging earlobes and those with attached earlobes.
2. The presence or absence of free hanging earlobes versus attached earlobes was recorded for my siblings, my parents and myself.
3. Five additional classmates were selected at random (Given that I have free hanging earlobes, two (2) additional classmates were selected from the "free hanging earlobes" group" and three (3) from the "attached group". If I had had attached earlobes, 2 additional classmates would have been selected from the "attached group" and three (3) from the "free hanging earlobes group"). Earlobe information for my selected classmates as well as their siblings and both of their parents was collected.
4. The earlobe information for all six (6) students (including myself) and their siblings and parents were recorded in a table.
5. The phenotypic information for both groups was analyzed. The following questions were explored:
  - (a) Did all students with free hanging earlobes have both parents and all siblings with free hanging earlobes?
  - (b) Did all students with attached earlobes have both parents and all siblings with attached earlobes?
  - (c) Assign genotypes to the parents and use Punnett squares and Mendelian genetics to predict the genotypes of the offspring (students and their siblings). Based on your analysis, are free hanging earlobes a dominant or recessive trait? Why or why not?



**Results**

**TABLE 1 -SHOWING EARLOBE INFORMATION FOR THE 6 STUDENTS, THEIR SIBLINGS AND THEIR PARENTS**

#	Group 1: Free Hanging	Siblings	Parents	#	Group 2: Attached Earlobe	Siblings	Parents
1.	Michael*	Tyson- <i>Free</i>	Mom: <i>Free</i> Dad: <i>Free</i>	4.	Veronica	Ty- <i>Attached</i> Mike- <i>Attached</i>	Mom: <i>Attached</i> Dad: <i>Attached</i>
2.	Shawon	Nekisha- <i>Free</i> Yohan- <i>Free</i>	Mom: <i>Attached</i> Dad: <i>Free</i>	5.	Shantelle	Chris- <i>Attached</i> Leonnie- <i>Free</i>	Mom: <i>Free</i> Dad: <i>Free</i>
3.	Allison	Kevin- <i>Attached</i> Jacob- <i>Attached</i> Maxine- <i>Free</i>	Mom: <i>Free</i> Dad: <i>Attached</i>	6.	Tyson	Tanisha- <i>Free</i>	Mom: <i>Free</i> Dad: <i>Attached</i>

*Free*- Free hanging earlobes

*Attached*- Attached earlobes

(\*) Represents person conducting the experiment

Note: Not all children with attached earlobes had both parents with attached earlobes, nor did all children with free hanging earlobes have both parents with free hanging earlobes.

**TABLE 2 SHOWING COMMENTS BASED ON PHENOTYPE OF PARENTS AND CHILDREN.**

#	Student	Comments
1.	Michael	Both of Michael's parents have free hanging earlobes and both children including Michael have free hanging earlobes. This would support free hanging earlobes being a dominant trait. This would support the hypothesis and expected results.
2.	Shawon	Shawon's mom has attached earlobes while her dad has free hanging earlobes. However, all the children have free hanging earlobes. This would suggest that free hanging earlobes are dominant to attached earlobes
3.	Allison	Allison's mom has free hanging earlobes while her father has attached earlobes. However, two of the children have attached earlobes and two of the children have free hanging earlobes. This would indicate that free hanging is dominant but that the parent (mom) with free hanging earlobes would have to be heterozygous (Ee). That is the only way they could have children that are have both free hanging and attached.
4.	Veronica	Veronica's parents both have attached earlobes. Veronica and her two siblings also have attached earlobes. This would support that attached earlobes is recessive and that if both parents have it (ee) then all children will be born homozygous recessive (ee) and have attached earlobes.
5.	Shantelle	Both of Shantelle's parents have free hanging earlobes. However, only one of the three children has free hanging earlobes. Two have attached earlobes. These observations indicate that both parents have to be heterozygous dominant (Ee). This would make it possible that two parents with free hanging earlobes would still be able to have children with free hanging and attached earlobes.
6.	Tyson	Tyson's mom has free hanging earlobes while his dad has attached earlobes. One of the children has free hanging earlobes while the other has attached earlobes. This would indicate that Tyson's mother has to be heterozygous (Ee) and his dad has to be homozygous recessive (ee). That would be the only combination of genotypes that would result in children with attached or free hanging earlobes

PUNNET SQUARES: Based on the observations, we will assume free hanging earlobes to be a dominant trait. Homozygous dominant (AA) as well as heterozygous (Aa) will represent Free Hanging Earlobes; while homozygous recessive (aa) can only represent Attached Earlobes.

1. Possible Genotype of Michael's parents and those of the children.

		<b>DAD: Free</b>	
		E	E
<b>MOM: Free</b>	E	EE	EE
	E	EE	EE

All children would have free hanging earlobes.

2. Possible Genotype of Shawon's parents and those of the children.

		<b>DAD: Free</b>	
		E	E
<b>MOM: Attached</b>	e	Ee	Ee
	e	Ee	Ee

All children would still have free hanging earlobes but their genotype would be heterozygous (Ee). Because free hanging is dominant to attached, having one copy of the "E" would be enough to have children with free hanging earlobes.

3. Possible Genotype of Allison's parents and those of the children.

		<b>DAD: attached</b>	
		e	e
<b>MOM: Free</b>	E	Ee	Ee
	e	ee	ee

Half of the children could have free hanging and half could have attached. The Mendelian ratio would be 1:1.

4. Possible Genotype of Veronica's parents and those of the children.

		<b>DAD: attached</b>	
		e	e
<b>MOM: Attached</b>	e	ee	ee
	e	ee	ee





If both parents are homozygous recessive (ee)/Attached earlobes, then all children would have attached earlobes.

5. Possible Genotype of Shantelle’s parents and those of the children.

		<b>DAD: Free</b>	
		E	e
<b>MOM: Free</b>	E	EE	Ee
	e	Ee	ee

If both parents were heterozygous, they would still show free hanging earlobes. However, their children could either display free hanging or attached earlobes. The ratio would be 3:1

6. Possible Genotype of Tyson’s parents and those of the children.

		<b>DAD: Attached</b>	
		e	e
<b>MO M:</b>	E	Ee	Ee
	e	ee	ee

If the mom is heterozygous (Ee) and the dad homozygous recessive (ee), then they could have children with free hanging ear lobes or attached earlobes in a ratio of 1:1.

### Discussion

Simple dominance is a case where a single dominant allele will mask the expression of a single recessive allele. As such, persons with a physical characteristic only need one parent to show that trait for it to show up in the children. In the case of simple dominance, a person with the dominant trait could either be (EE or Ee) because only 1 of the dominant alleles is necessary to show the trait.

Information on phenotypes of parents can be used to create monohybrid crosses using Punnet squares to determine Mendelian ratios regarding possible expression of traits in offspring. The prediction is simply a matter of listing all the possible combinations of alleles in for a given offspring/child. From these results it will be possible to determine whether free hanging or attached earlobes is a dominant trait.

From the phenotypic data and Punnet square crosses it was clear that our hypothesis was not fully supported. Two parents with free hanging earlobes can still have children with attached earlobes because they could both be heterozygous dominant. A cross between Ee x Ee would result in a 3:1 phenotypic ratio of “Free-Hanging” to “Attached”. However, two parents with homozygous dominant genotype EE x EE could only produce children with free hanging earlobes. Two parents with attached earlobes (homozygous recessive alleles) ee x ee could only have children with attached earlobes. Other combinations are also possible, e.g. example, Ee x ee or EE x ee.

### Conclusion

“Free Hanging” earlobe is a dominant trait. For a child to have free hanging earlobes, he only needs at least one parent to have free hanging earlobes because the “E” allele masks the “e” allele. For a person to show attached earlobes, he/she would need to get an “e” allele from each parent. Both parents will have to carry the recessive form of the gene, even though both may have ‘free hanging’ ear lobes



### **Limitations**

Every effort was made to reduce experimental error in this experiment. However, the experiment may be improved by:

1. Including information on grandparents;
2. Also, care must be taken with obtaining accurate information on the phenotype of their siblings and parents, from classmates.

### **Reflections**

From this investigation, I have acquired a better understanding of genetics including genes, alleles, genotype versus phenotype, and Mendelian ratios. I can now appreciate how traits are passed on from one generation to another using information from a simple survey. I now realize that some traits are dominant while others are recessive and that it is our genotype that determines whether a trait will be expressed as a physical characteristic (for example, hair color, freckles, dimples, free hanging versus attached earlobes). This investigation also has applications to the study of genetic diseases, which can also be passed on from parent to offspring. One of the most striking things I learned from this investigation is that both parents can have free hanging earlobes but their child could still be born with attached earlobes. This could apply to cases where parents appear normal but a child is born with a genetic disorder. Overall, this was an interesting practical where I got to apply critical thinking skills to answer questions about heredity.

This practical is based on Section C, Continuity and Variation, Specific Objectives 1.1 and 2.7-2.10.

**Note to the teacher:** For discrete traits, students don't have to be limited to the ear lobe phenotype. They can use traits including dimples, hairline and, tongue rolling. They can also use data from continuous traits such as height. Also, if the practical is overwhelming with 6 students, it can be done with 4 students.

### **Safety**

Teachers should observe all the following safety precautions before conducting laboratory work:

1. Investigations involving human blood and other fresh human material (for example, cheek cell, saliva) should NOT be conducted;
2. Extreme care should be taken when handling live animals. Wild rodents should not be handled since they pass on disease by biting or through their urine. These diseases include leptospirosis;
3. A fire extinguisher or fire blanket must be readily accessible. Teachers and students should know how to use them. The extinguisher purchased should be appropriate for a biology laboratory;
4. A first-aid kit should be kept in the laboratory and should be checked regularly for *replenishment of supplies*;
5. Corrosive solutions and inflammable solvents (for example, concentrated acids, alcohols) should be clearly labelled as such and handled with great care and should be locked away when not in use.
6. Candidates should know the correct way to light and use a Bunsen burner. Flints rather than matches are safer to use;
7. Electrical equipment and fittings should be regularly checked and serviced. Electrical outlets should be properly labelled (for example, 110v and 220v);
8. A laboratory safety manual *must* be available.



## **Audio-Visual Aids**

The dynamic nature of biology requires the teacher to make use of a variety of resource materials as teaching aids. Audio-visual aids are particularly useful to reinforce and deepen understanding.

Resource materials are available for use with:

1. Film projectors;
2. Slide projectors;
3. Multimedia projectors;
4. CD-ROM and other interactive media.

Cost might prohibit departmental ownership but hardware may be kept in a common pool for use within a school or among a group of schools.

Sources of materials include:

1. Overseas information services, for example, USIS, UNESCO, High Commissions;
2. Tertiary institutions;
3. Government ministries;
4. The media: - television, radio, newspapers;
5. The Internet.

## ***Moderation of School-Based Assessment***

*The reliability (consistency) of the marks awarded by teachers on the School-Based Assessment is an important characteristic of high quality assessment. To assist in this process, the Council undertakes on-site moderation of the School-Based Assessment, conducted by visiting external Moderators.*

*During the Term 2 of Year 2, the Moderator will visit. Teachers must make available to the Moderator **ALL** Assessment Sheets (Record of Marks and the report on the Investigation). **Teachers are NOT required to submit to CXC samples of candidates' work, unless specifically requested to do so by the Council BUT will be required to submit the candidates' marks electronically.***

*The Moderator will remark the skills, and investigation reports for a sample of five candidates, who are selected using the guidelines listed below.*

1. *Candidates' total marks on the SBA are arranged in descending order (highest to lowest);*
2. *The candidates scoring the:*
  - (a) *highest Total mark;*
  - (b) *middle Total mark;*
  - (c) *lowest Total mark;*
  - (d) *mark midway between the highest and middle Total mark;*
  - (e) *mark midway between the middle and lowest Total mark;*

*are selected to perform some practical skills.*

*Teachers' marks may be adjusted as a result of the moderation and feedback will be provided by the Moderator to the teachers.*



The Moderator may re-mark additional candidates. Where the total number of candidates is five or fewer, the Moderator will remark ALL.

On this visit, the Moderator will also re-mark a sample of the laboratory books of Year 1 candidates, as well as provide assistance and guidance to the teachers of the Year 1 students. A copy of this report must be retained by the teacher, and be made available to the Moderator during the second term of Year 2.

The Moderator will submit the Assessment Sheets, moderation of SBA Sample and the moderation reports to the Local Registrar by April 30 of the year of the examination. A copy of the Assessment Sheets and candidates' work must be retained by the school, until three months after publication, by CXC, of the examination results.

School-Based Assessment Record Sheets are available online via the CXC's website [www.cxc.org](http://www.cxc.org).

All School-Based Assessment Record of marks must be submitted online using the SBA data capture module of the Online Registration System (ORS). A sample of assignments will be requested by CXC for moderation purposes. These assignments will be re-assessed by CXC Examiners who moderate the School-Based Assessment. Teachers' marks may be adjusted as a result of moderation. The Examiners' comments will be sent to schools. All samples must be delivered to the specified marking venues by the stipulated deadlines.

Copies of the students' assignment that are not submitted must be retained by the school until three months after publication by CXC of the examination results.

### **Criteria for the Assessment of Each Skill**

This syllabus is grounded in the philosophy and methodology of all science disciplines. The teaching strategies that are recommended for its delivery are dictated by the scientist's approach to a task. A problem to be identified will be examined in the light of available evidence and suggestions or hypotheses as to its solution formulated. These will then be tested by repeated practical observations, modified or discarded as necessary, until a hypothesis that does offer a solution is found.

The history of scientific thought shows that new ideas replace old ones that were previously accepted as factual. Students must be made to realise that no solution is final and infallible since modifications are continually made in light of new knowledge and technology.

The following are examples of how to conduct assessments of the *skills listed under Experimental Skills and Use of Knowledge (Analysis and Interpretation)*

#### **TASKS**

#### **ASSESSMENT CRITERIA**

##### **Experimental Skill:**

##### **1. Observation/Recording/Reporting**

Candidates should be able to make observations and record/report them by:

- (a) presenting diagrams of apparatus, models and specimens;

Descriptions, tables or diagrams:  
Method clearly described, logical sequence of activities, adequate details; tables, diagrams appropriately neat.



## **TASKS**

- (b) summarising data, using mean, median and range; by constructing tables, graphs, histograms, maps and pie charts;
- (c) presenting written reports of investigations.

(Candidates are to be encouraged to use all senses or extensions of them, for example, hand lens).

### **2. Drawing**

Candidates should be able to:

make large, clear, accurate line representations of specimens, with appropriate labeling and annotations.

### **3. Manipulation/Measurement**

Candidates should be able to:

- (a) use basic laboratory equipment with competence and skill, handle selected measuring devices and take accurate readings;
- (b) prepare biological materials for observation or investigation;
- (c) handle living things with care.

## **ASSESSMENT CRITERIA**

Accuracy of observations/recordings:  
Significant changes recorded; extent or degree of change recorded; original and final condition compared; condition of control included (if relevant).

Format:  
Aims, apparatus, materials. All present in the correct sequence; correct content under each heading.

Language and expression:  
Correct tense and voice. Few or no grammatical errors.

Clarity:

Clean continuous lines of even thickness in pencil with no shading or unnecessary details; reasonable size.

Accuracy:  
Faithfulness of reproduction; structures are typical of specimen; proportions are reasonable.

Labeling/Labeling lines:  
Neat, drawn with a ruler; labeling lines are straight and do not cross one another. There is the inclusion of magnification, view or section where appropriate; there is a title.

Extent of facility in using pH paper, thermometer, metre rule, quadrat, measuring cylinder, watch or clock or other timing device, cobalt chloride paper and balances.

Correct handling of equipment for collecting specimens.



## TASKS

## ASSESSMENT CRITERIA

### 4. Planning/Designing

Candidates should be able to:

- (a) suggest hypotheses on the basis of observation(s);
- (b) design methods to test their own or other hypotheses.

Hypotheses should include an identification of the problems on which they are based.

Inclusion of apparatus and materials to be used; Description of procedures; suggestions of controls where appropriate; Statement of expected results and limitations.

### Use of Knowledge:

### 5. Analysis and Interpretation

- (a) identify and explain relationships and patterns;
- (b) draw logical conclusions and make predictions from observations and data.

Include labels and annotations of structures.

Inclusion of the following:

- (a) the limitations of the observations and data;
- (b) the relationship between results and original hypothesis.

**Example of Possible SBA Practical for Experimental Skill:**

**1. Manipulation and Measurement**

**STEP I - Select an appropriate practical activity, for example:**

Investigating osmosis in living tissue (Specific Objective B1.5)

**STEP II - Decide what Manipulation and Measurement tasks are appropriate for assessment, for example:**

**TASKS**

**ASSESSMENT CRITERIA**

**Experimental Skill:**

**Manipulation/Measurement (cont'd)**

Candidates should be able to:

- |  |  |
|--|--|
| (a) cut strips of potato each 4cm x 1cm x 1cm;   | All peel removed from strips.<br>All four strips of equal dimensions ( $\pm 1\text{mm}$ ).<br>Edges of strips straight to ensure accurate measurement. |
| (b) immerse two strips in a dish A containing water and two strips in dish B containing salt solution; | Strips completely immersed in solutions.<br>All strips placed in dishes at the same time.  |
| (c) remove strips after 30 minutes;  | Ability to cut strips neatly to given dimensions.<br>Accurate measurement of strips.   |
| (d) dry strips on tissue and measure dimensions.   | Handling of apparatus and materials competently.   |

**STEP III - Construct a Mark Scheme based on Assessment Criteria, for example:**

Each criterion satisfactorily done (2 marks)

**STEP IV - Record Marks**

Enter marks in teacher's mark book.

**2. Planning and Design**

**STEP I - Select an appropriate practical activity, for example:**

Suggesting an hypothesis and designing an investigation based on the following observation: A farmer notices that the grass is greener in the areas of a field where animals have been tied for grazing.



**STEP II - Decide what Planning and Designing skills are appropriate for assessment, for example:**

**TASKS**

**ASSESSMENT CRITERIA**

**Experimental Skill:**

**Planning and Design**

Candidates should be able to:

- |   |  |
|---|--|
| (a) suggest a suitable hypothesis;                          | Hypothesis statement relates directly to observation.  |
| (b) state the hypothesis appropriately;                     | Makes sense (is logical) and testable.   |
| (c) design a suitable investigation to test the hypothesis. | Aim of investigation relates to hypothesis.<br>Materials and apparatus appropriate.<br>Method suitable, includes reasonable control.<br>Attempt made to control other conditions or variables.<br>Size of samples reasonable and procedure repeated for accuracy.<br>Expected results and how they will be interpreted.<br>Limitations noted.<br>Format suitable for planning and design activity. |

**N.B.: Investigations showing no evidence of planning and design (no observations or hypothesis stated, written in the past tense, and including results and conclusions will not be accepted for SBA.**

**STEP III - Construct a Mark Scheme based on Assessment Criteria, for example:**

Hypothesis acceptable	2 marks
Aim related to hypothesis	1 mark
Materials and apparatus	1 mark
Method suitable	2 marks
Control included	1 mark
Expected result and interpretation stated	1 mark
Limitations noted	1 mark
Suitable format	1 mark

Note different criteria carry different weights. Marks out of a total of less or more than 10 must be converted to the appropriate scale. An acceptable variation of the above mark scheme and how the marks are converted is shown on page 47.

**STEP IV - Record marks and enter in teacher's mark book.**

N.B.: Practical exercises that may be found in textbooks will not be accepted as Planning and Designing exercises.





Example of Possible SBA Practical for Use of Knowledge:

1. Analysis and Interpretation

**STEP I** - Select an appropriate practical activity, for example:

Investigate the effect of solutions of different concentrations on carrot tissue (SO. B1.6)

**STEP II** - Decide what Analysis and Interpretation skills are appropriate for assessment, for example:

**TASKS**

**ASSESSMENT CRITERIA**

**Use of Knowledge:**

**Analysis and Interpretation**

Candidates should be able to:

- |     |  |  |
|-----|--|--|
| (a) | establish that there are three strips of carrot of the same dimensions in three (3) different concentrated solutions ; | Background information provided.                               |
| (b) | observe the length of the strips after leaving them in the solutions for the same amount of time;                      | The effect of the different solutions on the strips of carrot. |
| (c) | discuss the results of the investigation;  | Include limitations.<br>Expectations or interpretations.       |
| (d) | draw logical conclusions.  | Conclusions based on data.<br>Conclusions related to aim.      |

**STEP III** - **Construct a Mark Scheme based on Assessment Criteria, for example:**

Background information	2 marks
Explanations or interpretation	3 marks
Conclusion	2 marks
Limitations	<u>1 mark</u>
<b>Total</b>	<b>8 marks</b>

**STEP IV** - **Record marks**

Marks converted to two-point scale.

$$\frac{\text{Students mark} \times 10}{8}$$

Adjusted mark recorded.

Enter marks in teacher's mark book.



### Conversion of Marks

Name	Proposed Hypothesis (2)	Suitable method (2)	Reasonable control (1)	Sources of error (1)	Expected results (1)	Logic for inference (2)	Out of 9 marks	Out of 10 marks
V. Allen	2	2	0	0	1	1	6	7
A. Williams	1	1	0	1	1	1	5	6
B. Cuthbert	1	2	1	0	0	0	4	4
J. Moore	2	1	1	1	1	1	7	8
S. Worte	1	1	0	0	1	0	3	3

### Conversion from Teacher's Rating Scale to CXC Standard 11-point Scale

V. Allen	$6/9 \times 10 = 6.67 = 7$
A. Williams	$5/9 \times 10 = 5.56 = 6$
B. Cuthbert	$4/9 \times 10 = 4.44 = 4$
J. Moore	$7/9 \times 10 = 7.78 = 8$
S. Worte	$3/9 \times 10 = 3.33 = 3$

### **Validity and Reliability of Teachers' Marks**

The reliability of marks awarded is a significant factor in SBA and has far-reaching implications for the candidate's final grade. Teachers are asked to note the following:

1. the criteria for assessing a skill should be clearly identified. A mark scheme must be submitted with the sample of books sent for moderation. Failure to do this could result in the candidates being unavoidably penalised;
2. the relationship between the SBA marks in the practical workbooks and those submitted to CXC on the SBA forms must be clearly shown. It is important that the marks awarded reflect the degree of mastery of the skills assessed;
3. workbooks should contain all practical work and those exercises used for SBA marks should be clearly identified. At least *ten* exercises should be undertaken;
4. the standard of marking must be consistent, hence the need for a mark scheme;
5. collaboration among teachers especially in the same centre is urged to minimise the discrepancy in the standard of assessment between teachers.

### **Record Keeping**

Each candidate is required to keep a practical workbook containing all practicals done over the two-year period prior to the examination. Those assessed for CXC will be used to determine the standard of marking by the teacher. **A mark scheme must be sent with each set of books.** All practicals should be dated and an index made by the candidates of the practicals done. Those assessed for CXC should be clearly indicated along with the marks awarded for each skill.

Candidates' workbooks should be durable and neatness should be encouraged. The pages should be numbered and all exercises should be dated. The workbook should contain a contents page providing the following information concerning the practicals:

1. page number;
2. date;
3. aim of practical;
4. an indication by an asterisk, of which practicals were assessed for CXC;
5. the skills assessed.

### **Teachers**

An example of the teacher's records follows:



## Recording Marks for SBA

### TEACHER'S MARK BOOK

SKILLS	OBSERVATION RECORDING/ REPORTING			DRAWING			MANIPULATION/ MEASUREMENT			PLANNING AND DESIGN				ANALYSIS AND INTERPRETATION			TOTAL YR1
	31/11	14/4	Avg. (10)	2/12	23/2	Avg. (10)	15/10	1/5	Avg. (10)	15/1	3/3	14/5	Avg. (10)	11/3	9/5	Avg. (10)	
NAMES																	50
Allen, Veronica	6	8	7	2	8	5	8	10	9	5	7	8	7	6	7	7	35
Williams, Ann	4	4	4	7	7	7	6	9	8	4	7	7	6	7	9	8	33
Cuthbert, Bryan	5	5	5	3	10	7	9	7	8	6	6	7	6	3	8	6	32
Moore, Jason	9	9	9	2	3	3	0	8	7	8	9	8	8	5	7	6	33
Worte, Stewart	3	6	5	9	0	5	3	5	4	5	8	8	7	4	5	5	26

**Note that no special assessment exercises need to be planned.** The teachers will, as is customary, be recording periodic "marks" for all students. The difference is that, since these "marks" will now contribute to an assessment external to the school, they need to be more carefully arranged to clearly stated criteria.



## ◆ RECOMMENDED MINIMUM EQUIPMENT LIST (for a class of 25 students)

Several of the items listed may be produced within the school.

- |  |  |
|--|--|
| 1. 1 Aquarium or glass trough                                      | 28. Nets for collecting specimens                        |
| 2. 1 Balance (top pan or triple beam)                              | 29. 1 Oven, access to                                    |
| 3. 25 Beakers 400 cm <sup>3</sup> /500 cm <sup>3</sup> (graduated) | 30. 5 Pooters with spare specimen tubes (not ready made) |
| 4. 25 Beakers 250 cm <sup>3</sup> (graduated)                      | 31. 2 Potometers (not ready made)                        |
| 5. 2 Bell jars with bungs  | 32. 1 Pump, filter                                       |
| 6. 50 Bottles reagent, assorted                                    | 33. Quadrats, assorted                                   |
| 7. 3 Buckets, plastic, with covers                                 | 34. Racks, test tube                                     |
| 8. 15 Burners, Bunsen  | 35. 1 Box Razor Blades, single-edged                     |
| 9. 1 set Borers, cork  | 36. 1 Refrigerator, small                                |
| 10. Charts and models  | 37. 5 Rules, metre                                       |
| (a) 1 Eye, human   | 38. 1 Pair Scissors                                      |
| (b) 1 Skeleton, human  | 39. 1 Pair Secateurs                                     |
| (c) 1 Skin, human  | 40. 2 Shelves, beehive                                   |
| (d) 1 System, female reproductive, human                           | 41. 12 Slides, cavity                                    |
| (e) 1 System, male reproductive, human                             | 42. 1 Box Slides, microscope                             |
| 11. 100 Coverslips or cover glasses                                | 43. 10 Stands, retort with 20 clamps                     |
| 12. 10 Crucibles with lids   | 44. 15 Stands, tripod                                    |
| 13. 10 Cylinders, measuring, assorted                              | 45. 5 Stop Clocks  |
| 14. 1 Desiccator   | 46. Stoppers or bungs, assorted cork, rubber             |
| 15. 5 Dishes, evaporating, porcelain                               | 47. 2 Tapes, measuring (30 metres)                       |
| 16. 25 Dishes, Petri   | 48. 15 Thermometers, -100 to 110°C (Spirit)              |
| 17. 10 Flasks, conical 250 ml                                      | 49. 10 pairs of Tongs, crucible                          |
| 18. 10 Funnels, filter (assorted)                                  | 50. 5 Triangles, pipe-clay                               |
| 19. 25 pairs of Forceps  | 51. 2 Troughs, pneumatic, glass                          |
| 20. 25 Holders, test tube  | 52. 25 Tubes, boiling                                    |
| 21. 2 Jars, gas with cover plates                                  | 53. Tubing, glass, assorted                              |
| 22. 25 Jars, gas with screw-top lids                               | 54. Tubes, test, assorted                                |
| 23. 12 Knives or scalpels  | 55. 2 Tubes, Y-piece connector                           |
| 24. 25 Lenses, hand  | 56. Tubing, capillary, select lengths                    |
| 25. 1 Microscope, dissecting                                       | 57. Tubing, rubber, normal and heavy wall                |
| 26. Microscope, light. Magnification x 40 objective, x 10 eyepiece | 58. 15 Wire Gauzes, with insulated centers               |
| 27. 15 Mirrors, plane  |  |

◆ **RECOMMENDED MATERIAL LIST** (for a class of 25 students for 2 years)

- |   |  |
|---|--|
| 1. 2½L Alcohol or ethanol                           | 17. Plasticine                         |
| 2. Bags, plastic                                    | 19. 50 Pipettes, teat (droppers)       |
| 3. Balloons   | 18. 1kg Sodium Chloride (table salt)   |
| 4. Bands, rubber, assorted sizes                    | 19. 250g Sodium Hydrogen Carbonate     |
| 5. 500 cm <sup>3</sup> Benedict's solution          | 20. 100g Sodium Hydroxide (pellets)    |
| 6. 500g Calcium Hydroxide                           | 21. 2½L Spirits, methylated            |
| 7. Cobalt Chloride paper                            | 22. 1 roll Tubing, Dialysis or Visking |
| 8. 250g Copper II Sulphate                          | 23. 1 bottle Vaseline                  |
| 9. 250 ml Methylene blue solution 1%                | 24. Slides, prepared                   |
| 9. 2½L Hydrochloric acid (conc.)                    | (a) 6 Leaf, T.S.                       |
| 10. Indicator, Universal pH paper                   | (b) 6 Root tip, L.S.                   |
| 11. 250 ml Indicator, Universal pH, solution        | (c) 6 Dicot Stem, T.S.                 |
| 12. 250 ml Iodine in potassium iodide (KI) solution | (d) 6 Dicot root, T.S.                 |
| 13. Litmus paper, neutral                           | (e) 6 Human blood smear                |
| 14. Masking tape                                    | (f) 6 Onion tips                       |
| 15. Paper, absorbent or cotton wool                 | (g) 6 Xylem, T.S.                      |
| 16. Paper, filter                                   | (h) 6 Phloem, L.S.                     |
|   | (i) 6 Frog Blood Smear                 |
|   | 25. Skeleton                           |
|   | (a) 1 Skeleton, mammalian, complete    |
|   | (b) Vertebrae                          |
|   | (c) Girdles                            |
|   | (d) Long bone                          |
|   | (e) Skulls                             |
|   | (f) Teeth                              |

## ◆ RESOURCE MATERIALS

### Texts

- Atwaroo-Ali, L. *CXC Biology*, Oxford: Macmillan Caribbean, 2003.
- Bradfield, P. and Potter, S. *Longman Biology for CSEC*, 2<sup>nd</sup> edition, England: Pearson Education Limited, 2008.
- Kirby, P., Madhosingh, L. and Morrison, K. *Biology for CSEC*, United Kingdom: Nelson Thornes, 2008.

### Journals and Periodicals

- |                                 |                       |
|---------------------------------|-----------------------|
| American Biology Teacher        | School Science Review |
| Biologist                       | Science Digest        |
| Cajanus                         | Scientific American   |
| Discover                        | The Science Teacher   |
| Journal of Biological Education |                       |
| New Scientist                   |                       |

### Websites

- Barbados Action Plan UNEP  
<http://www.un.org/documents/ga/conf167/aconf167-9.htm>  
<http://www.unep.ch/regionalseas/partners/sids.htm>
- Caribbean Environmental Outlook Report  
[http://hqweb.unep.org/geo/pdfs/Caribbean\\_EO\\_final.pdf](http://hqweb.unep.org/geo/pdfs/Caribbean_EO_final.pdf)
- Understanding Evolution – University of California, Berkeley  
<http://evolution.berkeley.edu/>
- National Evolutionary Synthesis Center (NESCENT)  
<http://www.nescent.org/eog/archivednews.php>
- Biological Sciences Curriculum Study (BSCS)  
<http://www.bscs.org/curriculumdevelopment/highschool/evolution/>



## ◆ GLOSSARY

<u>WORD/TERM</u>	<u>DEFINITION/MEANING</u>	<u>NOTES</u>
account for	Present reason for action or event	UK
annotate	add a brief note to a label	Simple phrase or a few words only. KC
apply	use knowledge of principles to solve problems	Make inferences and conclusions; UK
assess	present reasons for the importance of particular structures, relationships or process	Compare the advantages and disadvantages or the merits and demerits of a particular structure, relationship or process; UK
calculate	arrive at the solution to a numerical problem	steps should be shown; units must be included; UK
classify	divide into groups according to observable characteristics	UK
comment	state opinion or view with supporting reasons	UK
compare	state similarities and differences	An explanation of the significance of each similarity and difference stated may be required for comparisons which are other than structural; UK/KC
construct	use a specific format to make and draw a graph, histogram, pie chart or other representation using data or material provided or drawn from practical investigations, build (for example, a model), draw scale diagram	Such representations should normally bear a title, appropriate headings and legend; UK, XS
deduce	make a logical connection between two or more pieces of information; use data to arrive at a conclusion	UK
define	state concisely the meaning of a word or term	This should include the defining equation or formula where relevant; KC
demonstrate	show; direct attention to...	KC

<b><u>WORD/TERM</u></b>	<b><u>DEFINITION/MEANING</u></b>	<b><u>NOTES</u></b>
describe	provide detailed factual information of the appearance or arrangement of a specific structure or a sequence of a specific process	Description may be in words, drawings or diagrams or any appropriate combination. Drawings or diagrams should be annotated to show appropriate detail where necessary; KC
determine	find the value of a physical quantity	UK
design	plan and present with appropriate practical detail	Where hypotheses are stated or when tests are to be conducted, possible outcomes should be clearly stated and/or the way in which data will be analyzed and presented; XS
develop	expand or elaborate an idea or argument with supporting reasons	KC/UK
diagram	simplified representation showing the relationship between components.	KC/UK
differentiate	state or explain briefly those differences between or among items which can be used to define the items or place them into separate categories.	UK
discuss	present reasoned argument; consider points both for and against; explain the relative merits of a case	UK
draw	make a line representation from specimens or apparatus which shows an accurate relation between the parts	In the case of drawings from specimens, the magnification must always be stated; KC/XS
estimate	make an approximate quantitative judgement	
evaluate	weigh evidence and make judgements based on given criteria	The use of logical supporting reasons for a particular point of view is more important than the view held; usually both sides of an argument should be considered; UK
explain	give reasons based on recall; account for	KC/UK



<b><u>WORD/TERM</u></b>	<b><u>DEFINITION/MEANING</u></b>	<b><u>NOTES</u></b>
find	locate a feature or obtain as from a graph	UK
formulate	devise a hypothesis	XS
identify	name or point out specific components or features	KC
illustrate	show clearly by using appropriate examples or diagrams, sketches	KC/UK
investigate	use simple systematic procedures to observe, record data and draw logical conclusions	XS
label	add names to identify structures or parts indicated by pointers	KC
list	itemise without detail	KC
measure	take accurate quantitative readings using appropriate instruments	XS
name	give only the name of	No additional information is required; KC
note	write down observations	XS
observe	pay attention to details which characterise a specimen, reaction or change taking place; to examine and note scientifically	Observations may involve all the senses and/or extensions of them but would normally exclude the sense of taste; XS
outline	Give basic steps only	XS
plan	prepare to conduct an investigation	XS
predict	use information provided to arrive at a likely conclusion or suggest a possible outcome	UK
record	write an accurate description of the full range of observations made during a given procedure	This includes the values for any variable being investigated; where appropriate, recorded data may be depicted in graphs, histograms or tables; XS



<b><u>WORD/TERM</u></b>	<b><u>DEFINITION/MEANING</u></b>	<b><u>NOTES</u></b>
relate	show connections between; explain how one set of facts or data depend on others or are determined by them	UK
sketch	make a simple freehand diagram showing relevant proportions and any important details	KC
state	provide factual information in concise terms outlining explanations	KC
suggest	offer an explanation deduced from information provided or previous knowledge. (... a hypothesis; provide a generalisation which offers a likely explanation for a set of data or observations.)	No correct or incorrect solution is presumed but suggestions must be acceptable within the limits of scientific knowledge; UK
test	to find out, following set procedures	XS

#### **KEY TO ABBREVIATIONS**

KC	-	Knowledge and Comprehension
UK	-	Use of Knowledge
XS	-	Experimental Skills

**Western Zone Office**  
13 August 2013



**CARIBBEAN EXAMINATIONS COUNCIL®**

**Caribbean Secondary Education Certificate  
(CSEC)®**



# **BIOLOGY**

**Specimen Papers and Mark Schemes/Keys**

Specimen Papers:	Paper 01 Paper 02 Paper 03/2
------------------	------------------------------------

Mark Schemes/Keys:	Paper 02 Paper 03/2
--------------------	------------------------

**FORM SPEC 2015****CARIBBEAN EXAMINATIONS COUNCIL****SECONDARY EDUCATION CERTIFICATE®  
EXAMINATION****BIOLOGY****Paper 01 – General Proficiency***1 hour 15 minutes***READ THE FOLLOWING INSTRUCTIONS CAREFULLY.**

1. This test consists of 60 items. You will have 1 hour and 15 minutes to answer them.
2. In addition to this test booklet, you should have an answer sheet.
3. Each item in this test has four suggested answers lettered (A), (B), (C), (D). Read each item you are about to answer and decide which choice is best.
4. On your answer sheet, find the number which corresponds to your item and shade the space having the same letter as the answer you have chosen. Look at the sample item below.

Sample Item

Which of the following diseases is due to a dietary deficiency?

Sample Answer

- (A) Malaria  
(B) Diabetes  
(C) Influenza  
(D) Anaemia

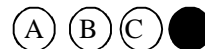

The best answer to this item is “Anaemia,” so answer space (D) has been shaded.

5. If you want to change your answer, erase it completely before you fill in your new choice.
6. When you are told to begin, turn the page and work as quickly and as carefully as you can. If you cannot answer an item, go on to the next one. You may return to this item later. Your score will be the total number of correct answers.
7. Figures are not necessarily drawn to scale.

---

**DO NOT TURN THIS PAGE UNTIL YOU ARE TOLD TO DO SO.**

---

Copyright © 2012 Caribbean Examinations Council  
All rights reserved.

Items 1–2 refer to the following diagrams labelled I, II, III, IV and V found in a school garden.

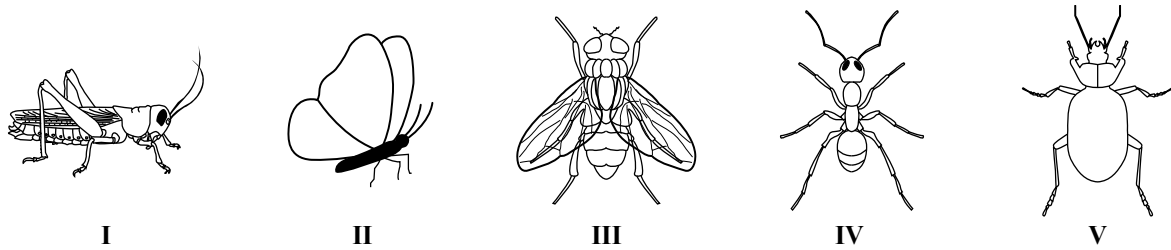

- Which of the following characteristics could be used to classify these organisms into two groups?
  - Number of wings
  - Segmented body
  - Number of legs
  - Antennae
- The distribution of the organism labelled I could be studied using
  - quadrats
  - sieves
  - line transects
  - nets

Item 3 refers to the following food web from a tropical forest.

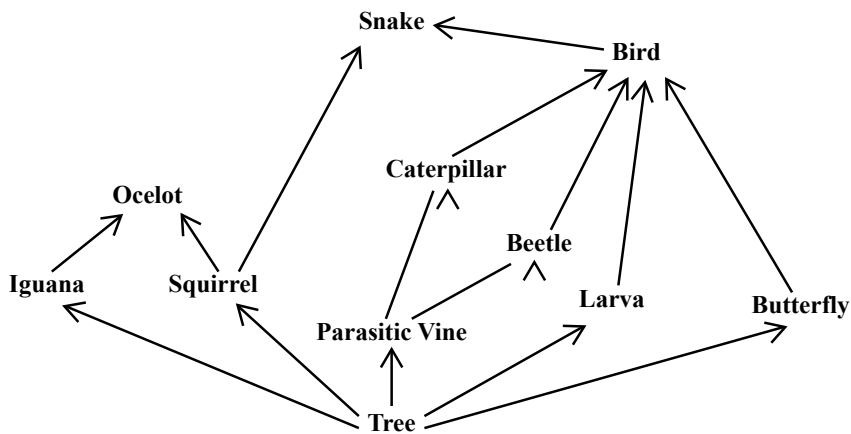

- The list of herbivores in the food web includes
  - iguana, parasitic vine, larva, butterfly
  - iguana, beetle, larva, butterfly
  - iguana, caterpillar, larva, bird
  - iguana, squirrel, snake, bird

GO ON TO THE NEXT PAGE

Item 4 refers to following relationships between some organisms.

- I Barnacles on a shark's back
- II Shark/man
- III Man/malaria protozoan

4. Which of the following correctly identifies these relationships?

	I	II	III
(A)	Commensalism	Predator/prey	Mutualism
(B)	Commensalism	Predator/prey	Parasitism
(C)	Predator/prey	Commensalism	Mutualism
(D)	Predator/prey	Mutualism	Parasitism

5. Which of the following statements about a food chain is true?

- (A) Energy from the sun is transferred from one organism to subsequent organisms.
- (B) Each of its members depends on heat energy obtained directly from the sun.
- (C) Energy changes from heat to light to chemical.
- (D) The sun traps light energy at the start of the food chain.

6. For which of the following would plants NOT compete?

- (A) Space
- (B) Light
- (C) Food
- (D) Water

Items 7–8 refer to the following diagram which represents an animal cell seen under an electron microscope. Some cell structures are labelled (A), (B), (C) and (D).

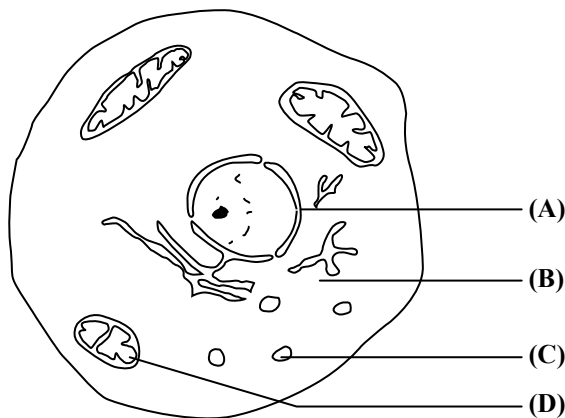

In answering items 7–8, each option may be used once, more than once or not at all.

Which of the structures

7. is responsible for energy production?

8. consists mainly of water?

GO ON TO THE NEXT PAGE



9. Which of the following pairs of phrases does NOT distinguish between plant and animal cells?

	<b>Plant Cells</b>	<b>Animal Cells</b>
(A)	Have chloroplasts	Do not have chloroplasts
(B)	Contain large vacuoles	Have few vacuoles
(C)	Have no cell membranes	Have cell membranes
(D)	Contain cellulose cell walls	Do not have cellulose cell walls

Items 10–11 refer to the following graph which shows the activity of two enzymes in the human digestive system.

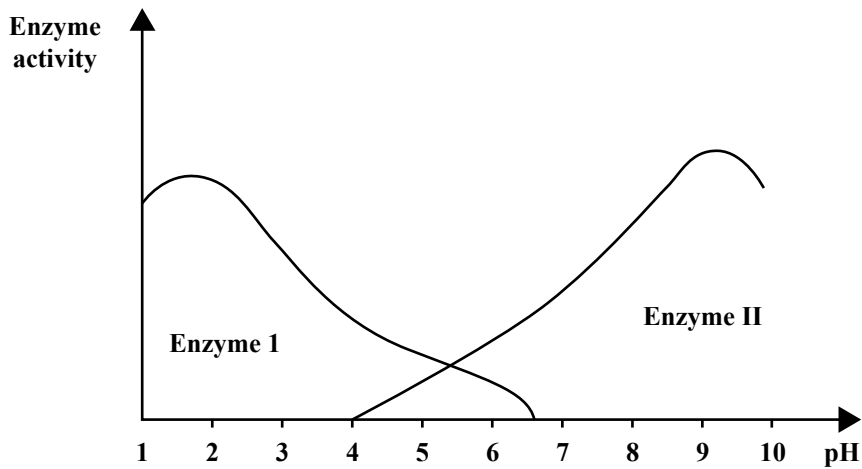

10. Enzyme I will function BEST in the

- (A) mouth
- (B) stomach
- (C) small intestine
- (D) large intestine

11. Which of the following is MOST likely Enzyme II?

- (A) Pepsin
- (B) Renin
- (C) Trypsin
- (D) Amylase

Items **12–13** refer to the following diagram which represents a metabolic process carried out in plants.

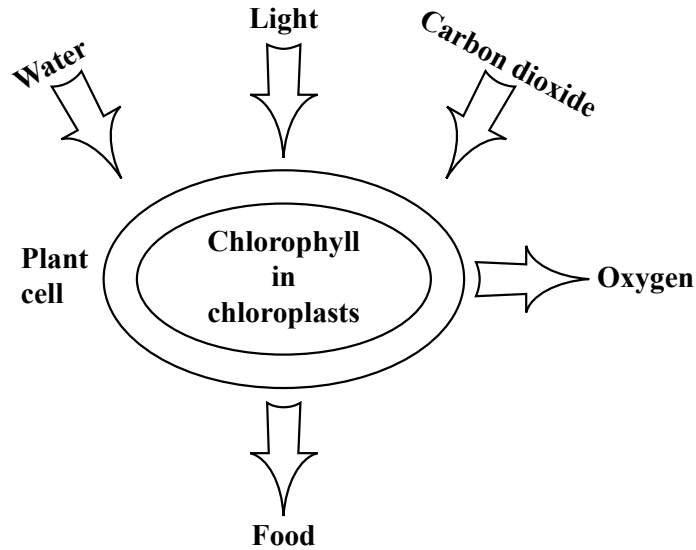

12. The oxygen shown in the diagram comes from the
- (A) atmosphere
  - (B) chlorophyll
  - (C) carbon dioxide
  - (D) water
13. To which of the following groups does the food produced belong?
- (A) Sugars
  - (B) Proteins
  - (C) Starches
  - (D) Fats

GO ON TO THE NEXT PAGE

Items 14–15 refer to the following diagrams, X and Y, which illustrate an experiment on a metabolic process taking place in light.

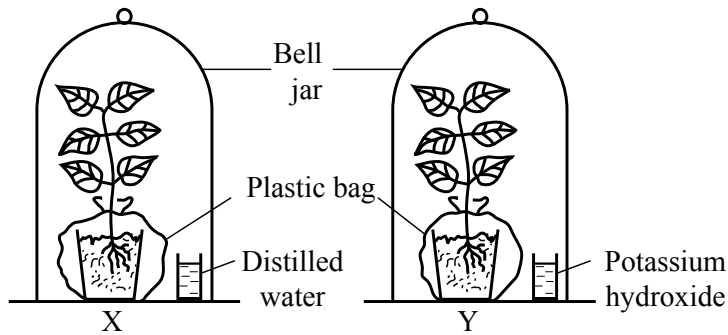

14. The aim of the experiment is to investigate
- (A) the effect of potassium hydroxide on the growth of plants
  - (B) the effect of water on the growth of plants
  - (C) if carbon dioxide is necessary for photosynthesis
  - (D) if oxygen is necessary for photosynthesis
15. Before the experiment is set up, the plants are placed in a dark cupboard for about twenty-four hours. This step is necessary to
- (A) reduce the quantity of sugar produced during photosynthesis
  - (B) allow the plant to get its store of carbon dioxide
  - (C) ensure that any starch produced is removed from the leaves
  - (D) stop further reduction of carbon dioxide to carbohydrate
16. Which of the following is important in a diet to develop strong bones and teeth?
- (A) Iron
  - (B) Vitamin C
  - (C) Vitamin D
  - (D) Calcium
17. Which of the following organs involved in digestion produces NO digestive enzymes?
- (A) Stomach
  - (B) Pancreas
  - (C) Liver
  - (D) Ileum
18. The products of aerobic respiration are
- (A) carbon dioxide and water
  - (B) carbon dioxide and lactic acid
  - (C) carbon dioxide and alcohol
  - (D) carbon dioxide only

GO ON TO THE NEXT PAGE

19. After vigorous exercise, the muscles involved show a marked increase in the concentration of
- (A) glucose
  - (B) glycogen
  - (C) lactic acid
  - (D) citric acid

Items 20–22 refer to the following diagrams of a model showing how breathing takes place.

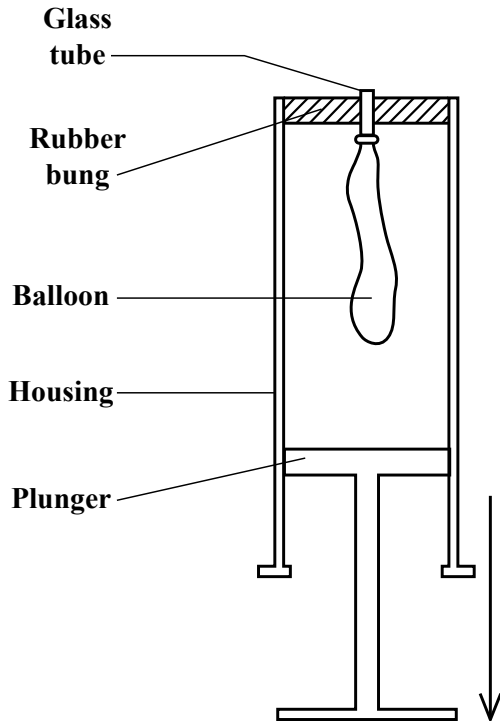

20. The part of the model which represents the diaphragm is the
- (A) rubber bung
  - (B) plunger
  - (C) balloon
  - (D) housing
21. Which of the following would MOST likely occur when the plunger is moved in the direction of the arrow shown in the diagram above?
- (A) The balloon will expand.
  - (B) A vacuum will be created.
  - (C) The volume of the apparatus would decrease.
  - (D) The pressure within the housing will increase.
22. When the plunger is moved, the balloon functions like the
- (A) alveolus
  - (B) bronchus
  - (C) diaphragm
  - (D) trachea

GO ON TO THE NEXT PAGE

23. The following are descriptions of blood vessels.
- I. Thin wall, large lumen, takes blood away from organs and tissues
  - II. Thin-walled vessel adapted for diffusion; close to cells
  - III. Thick wall, small lumen, takes blood to organs and tissues

Which of the following correctly identifies the blood vessels described above?

	I	II	III
(A)	Artery	Vein	Capillary
(B)	Vein	Capillary	Artery
(C)	Capillary	Vein	Artery
(D)	Artery	Capillary	Vein

24. The function of valves in veins is to
- (A) lower the pressure of blood
  - (B) increase the pressure of blood
  - (C) prevent the back flow of blood
  - (D) push blood forward
25. When a person receives a vaccine, his/her immune system is stimulated to produce
- (A) antigens
  - (B) antibiotics
  - (C) antibodies
  - (D) antitoxins
26. On what type of day is the rate of transpiration likely to be LOWEST?
- (A) Cool and sunny
  - (B) Cloudy and windy
  - (C) Hot and windy
  - (D) Cloudy and cool
27. In the kidney, blood vessels absorb most water from the
- (A) first (proximal) convoluted tubule
  - (B) loop of Henlé
  - (C) second (distal) convoluted tubule
  - (D) collecting duct

Items **28–29** refer to the following section through a kidney, with parts labelled (A), (B), (C) and (D).

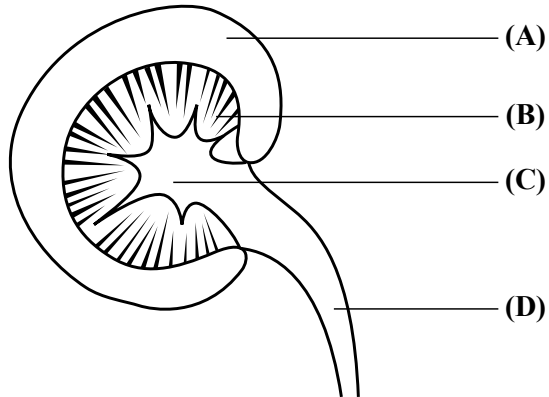

Match each of the items below with one of the parts labelled above. Each part may be used once, more than once or not at all.

- 28. Site of urine collection
- 29. Site of osmoregulation

Item **30** refers to the following diagram which represents a seedling growing in the dark.

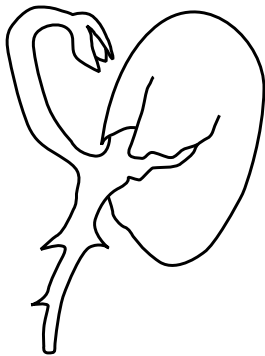

- 30. The plumule of the seedling is showing a
  - (A) negative response to gravity
  - (B) negative response to light
  - (C) positive response to gravity
  - (D) positive response to light

Item 31 refers to the following diagram which shows the skeleton of a human arm.

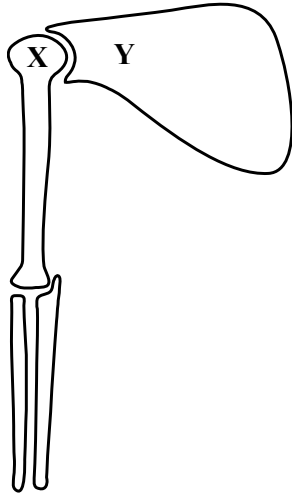

31. During performance of vigorous exercise, Bone X slips out of the socket in Bone Y. Besides experiencing pain, the individual would MOST likely be UNABLE to
- (A) flex the arm
  - (B) straighten the arm
  - (C) swing the arm
  - (D) pick up a pencil
32. Which part of the body do drugs affect MOST?
- (A) Stomach
  - (B) Brain
  - (C) Blood vessels
  - (D) Lungs

Item 33 refers to the following diagram of a reflex arc, with parts labelled (A), (B), (C) and (D).

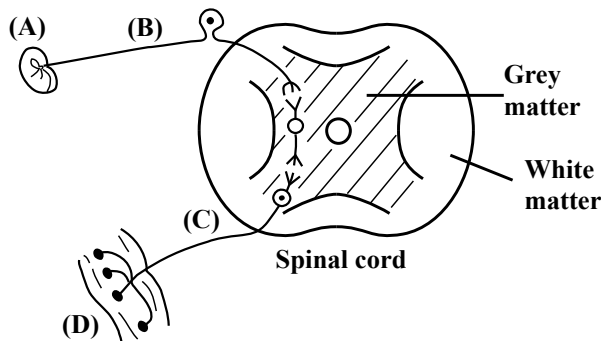

33. Which part of the reflex arc takes messages to the central nervous system?

34. Which of the following sequences is the correct pathway of a reflex action?
- (A) Receptor → Stimulus → Effector → Response
  - (B) Stimulus → Receptor → Effector → Response
  - (C) Effector → Stimulus → Receptor → Response
  - (D) Response → Stimulus → Effector → Receptor
35. The central nervous system consists of
- (A) the brain and the spinal cord
  - (B) the cerebrum, cerebellum and hypothalamus
  - (C) sensory, motor and relay neurones
  - (D) sight, smell, taste, hearing, touch
36. Which of the following is NOT true about drugs?
- (A) They are addictive.
  - (B) All are legally available to citizens.
  - (C) They alter normal bodily functions.
  - (D) They may cause liver damage and heart disease.
37. Which of the following structures are involved in the regulation of body temperature in humans?
- (A) Arterioles, sweat glands, hair erector muscles
  - (B) Epidermis, dermis, hypodermis
  - (C) Sebaceous gland, hair follicle, pain receptor
  - (D) Adipose tissue, sweat pores and hair
38. During the menstrual cycle, the egg is MOST likely to be released on Day
- (A) 5
  - (B) 11
  - (C) 14
  - (D) 28
39. When one side of the stem of a plant is illuminated the plant grows
- (A) thin and spindly
  - (B) away from the light
  - (C) towards the light
  - (D) and becomes etiolated
40. Which of the following is associated with germination?
- (A) Increased water content
  - (B) Increased food store
  - (C) Decreased metabolic activity
  - (D) Decreased water content



41. Which of the following is NOT used to measure growth in plants?
- (A) Total volume of all the organs
  - (B) Total number of leaves on the plant
  - (C) Changes in the fresh mass of all the organs
  - (D) Changes in the dry mass of all the organs
42. A seed develops from the
- (A) ovary
  - (B) embryo
  - (C) ovule
  - (D) pollen grain
43. Which of the following is a requirement for sexual reproduction?
- (A) Mitosis
  - (B) An aquatic habitat
  - (C) Optimal environmental conditions
  - (D) Production of gametes
44. Asexual reproduction gives rise to genetically identical offspring because
- (A) a single cell divides by meiosis
  - (B) only half the chromosomes are involved
  - (C) all the chromosomes are from one parent
  - (D) all cell divisions are by mitosis
45. After leaving the vas deferens, spermatozoa enter the
- (A) testes
  - (B) epididymis
  - (C) urethra
  - (D) ureter
46. Fertilization of the ovum takes place in the
- (A) vagina
  - (B) uterus
  - (C) oviduct
  - (D) ovary
47. Which of the following is considered a male hormone?
- (A) Oestrogen
  - (B) Progesterone
  - (C) Testosterone
  - (D) Follicle-stimulating hormone

48. Which of the following means of birth control is MOST effective in preventing sexually transmitted infections?
- (A) A condom
  - (B) The pill
  - (C) A diaphragm
  - (D) A spermicide
49. Animals assist with
- (A) pollination and seed dispersal
  - (B) pollination only
  - (C) seed dispersal only
  - (D) asexual reproduction in plants
50. The observable physical/biochemical characteristics or traits of an organism are referred to as its
- (A) genotype
  - (B) monotype
  - (C) phenotype
  - (D) prototype
51. Which of the following is an example of a discontinuous trait?
- (A) Foot size
  - (B) Height
  - (C) Intelligence
  - (D) Presence or absence of horns
52. Genetic variation is important because it
- (A) provides a basis for natural selection
  - (B) allows for survival against disease
  - (C) provides antibiotic resistance
  - (D) forms the basis for vaccines
53. Which of the following isolation mechanisms could lead to speciation (splitting into two different species)?
- I. Geographical
  - II. Behavioral
  - III. Ecological
- (A) I only
  - (B) II only
  - (C) II and III only
  - (D) I, II and III

54. Which of the following terms BEST describes two or more forms of the same gene?
- (A) Alleles
  - (B) Diploid
  - (C) Chromatids
  - (D) Chromosomes
55. Which of the following processes does NOT form part of meiosis?
- (A) Recombination
  - (B) Segregation
  - (C) Independent assortment
  - (D) Dependent assortment
56. Which of the following describes the sex chromosomes in humans?
- |     | <b>Females</b> | <b>Males</b> |
|-----|----------------|--------------|
| (A) | XX             | XXX          |
| (B) | XO             | XY           |
| (C) | XX             | XY           |
| (D) | XX             | Y            |
57. Which of the following BEST describes the process of evolution?
- (A) Development of characteristics in response to need
  - (B) Change of populations through time
  - (C) Development of populations due to natural selection
  - (D) Change from simple to complex organisms
58. Biological evolution is BEST defined as the
- (A) changes in species towards greater complexity over time
  - (B) changes in gene frequencies in a population over time
  - (C) ability of individuals to survive and produce offspring
  - (D) ability of individuals to respond to natural selection
59. Which of the following provide supporting evidence for biological evolution?
- I. Fossil record
  - II. DNA/genetic material
  - III. Vestigial traits (appendix, wisdom teeth)
- (A) I and II only
  - (B) I and III only
  - (C) II and III only
  - (D) I, II and III

60. Which of the following is the first step in the production of insulin using recombinant DNA?
- (A) Plasmid removed from *E. coli*.
  - (B) DNA coding for human insulin inserted in the plasmid.
  - (C) Plasmid closed by a special enzyme.
  - (D) Plasmid opened by a special enzyme.

**END OF TEST**

**IF YOU FINISH BEFORE TIME IS CALLED, CHECK YOUR WORK ON THIS TEST.**

TEST CODE **01207020**

**FORM SPEC 01207020/2015**

**C A R I B B E A N E X A M I N A T I O N S C O U N C I L**

**CARIBBEAN SECONDARY EDUCATION CERTIFICATE®  
EXAMINATION**

**BIOLOGY**

**Paper 02 – General Proficiency**

*2 hours*

**SPECIMEN PAPER**

**READ THE FOLLOWING INSTRUCTIONS CAREFULLY.**

1. This paper consists of SIX questions in two sections. Answer ALL questions.
2. For Section A, Write your answers in the spaces provided in the booklet.
3. For Section B, write your answers in the spaces provided at the end of each question, in this booklet.
4. Where appropriate, answers should be illustrated by diagrams.

---

**DO NOT TURN THIS PAGE UNTIL YOU ARE TOLD TO DO SO.**

**Copyright © 2012 Caribbean Examinations Council**

**All rights reserved**

**SECTION A**

**Answer ALL questions. Write your answers in the spaces provided in this booklet.**

1. A Biology class goes on a field trip to study a small coastal ecosystem along a busy highway. A student's sketch of the area investigated is shown in Figure 1.

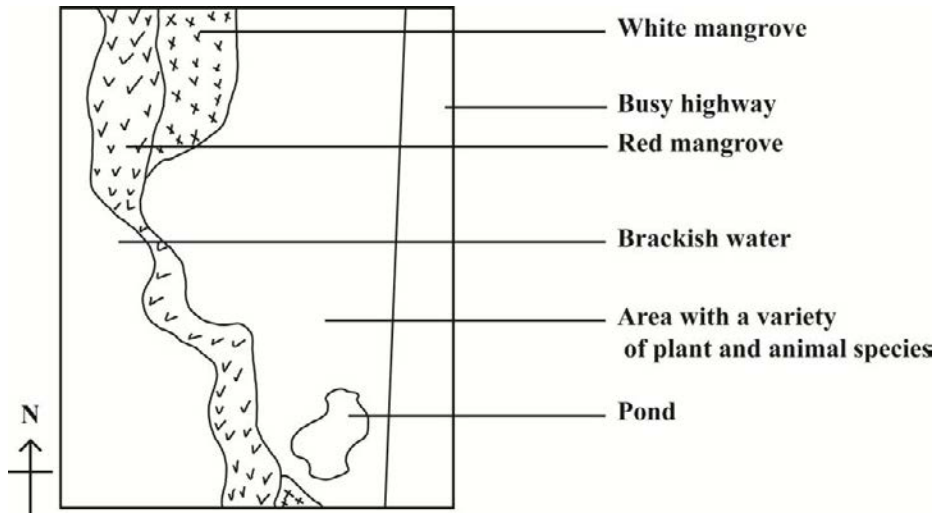

**Figure 1. Map of the area studied**

- (a) One group of students is given a 1 m<sup>2</sup> quadrat to study the area shown in Figure 1.
- (i) The distribution of the different plant and animal species changes from the water's edge to the highway. Name TWO additional pieces of apparatus the students will need to investigate the changing distribution of plant and animal species.

---

---

**(2 marks)**

- (ii) Describe how EACH piece of apparatus you named in (a) (i) can be used to study the distribution of plant species in this area.

---

---

---

**(2 marks)**

- (b) One group of students is given a 1 m<sup>2</sup> quadrat to determine the distribution of three plant species in the area behind the mangroves. The results are shown in Table 1.

**TABLE 1: RESULTS FROM QUADRAT THROWS**

Plant Organisms	Quadrat Number									
	1	2	3	4	5	6	7	8	9	10
Small flowering shrub	5	2	3	2	2	1	2	1	3	1
Grass growing in clumps	4	2	3	2	0	1	2	4	0	0
Succulent plant	10	10	12	15	20	25	15	22	5	18

- (i) State ONE precaution that should be taken when using the quadrat to determine the distribution of the plant species.

---

**(1 mark)**

- (ii) Calculate the species density of the small flowering shrub in the area. **(Show your working.)**

**(2 marks)**

GO ON TO THE NEXT PAGE

- (c) Another group of students observes the feeding relationship among the organisms found in and around the pond. The data recorded is shown in Table 2.

**TABLE 2: FEEDING RELATIONSHIPS OF ORGANISMS IN THE POND**

<b>Organism</b>	<b>Food Eaten</b>
Crab	Decaying plant matter
Guppy (fish)	Mosquito larvae, tadpoles
Water bird	Guppy, frog, crab
Water snail	Algae, water weed
Mosquito larvae	Moss, decaying plant matter
Water weed	Makes own food
Frog	Dragonfly, mosquito larvae
Tadpoles	Water weed

- (i) Using the information in Table 2, construct a food web with TEN organisms.

**(3 marks)**



- (ii) Explain why there are usually no more than four trophic levels in a food web.

---

---

**(2 marks)**

- (iii) State TWO physical (abiotic) factors that could affect the population of the organisms that live in the pond.

---

**(2 marks)**

- (d) Different groups of students collected data on the frog population from 1997 to 2004. Table 3 shows this data.

**TABLE 3: FROG POPULATION OBSERVED  
FROM OCTOBER 1997 TO OCTOBER 2004**

<b>Year</b>	<b>Population Size of Frogs (number of individuals)</b>
2004	5
2003	5
2002	35
2001	80
2000	110
1999	No data (No field trip due to hurricane)
1998	75
1997	125

- (i) Plot a graph to represent the data shown in Table 3, on the grid provided on Page 6. **(4 marks)**



- (ii) Account for the trend in the frog population before and after the hurricane.

---

---

---

**(3 marks)**

- (iii) Suggest ONE reason why it is useful to study the distribution of frogs.

---

---

**(2 marks)**

- (iv) Explain why frogs from this location were found to be unable to mate with frogs from another coastal location 10 km away.

---

---

---

---

**(2 marks)**

**Total 25 Marks**

2. (a) Figure 2 shows the structure of the human eye.  
Label the parts numbered 1 to 6 on the diagram in Figure 2.

**(6 marks)**

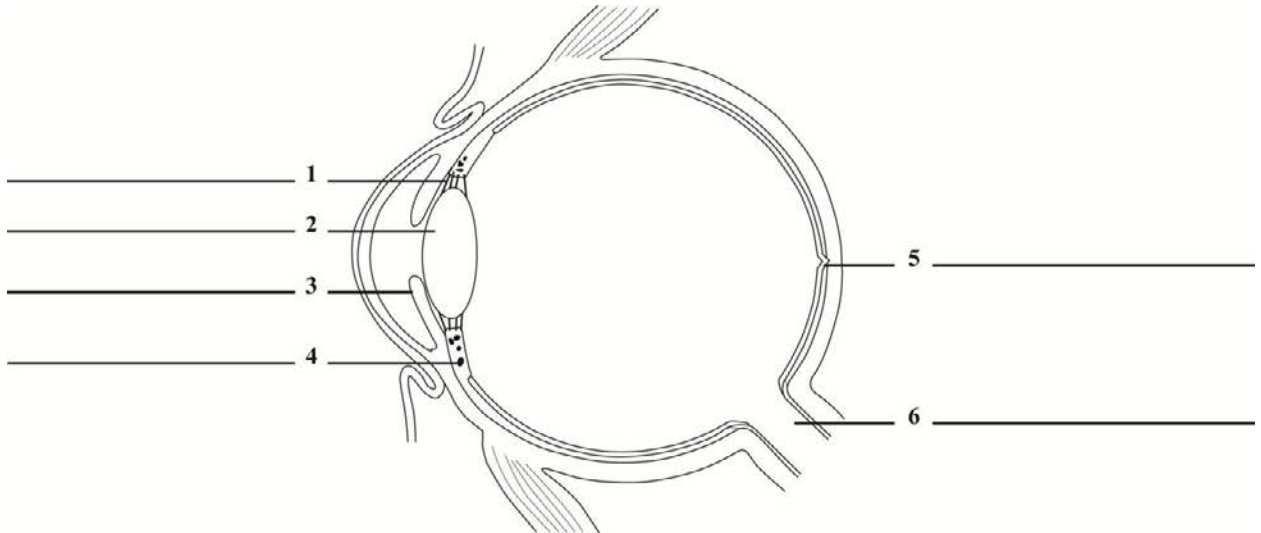

**Figure 2. A section through the human eye**

- (b) The rods and cones are specialised cells of the retina which are stimulated by light. What biological term describes such cells?

---

**(1 mark)**

- (c) Severe lack of Vitamin A can result in the cornea of the eye becoming dry and thickened. Explain how this condition would affect a person's ability to see.

---

---

**(2 marks)**

- (d) (i) Diagrams C and D in Figure 3 show two common eye defects, while Diagrams 7, 8 and 9 show three types of lenses that can be used to correct eye defects.

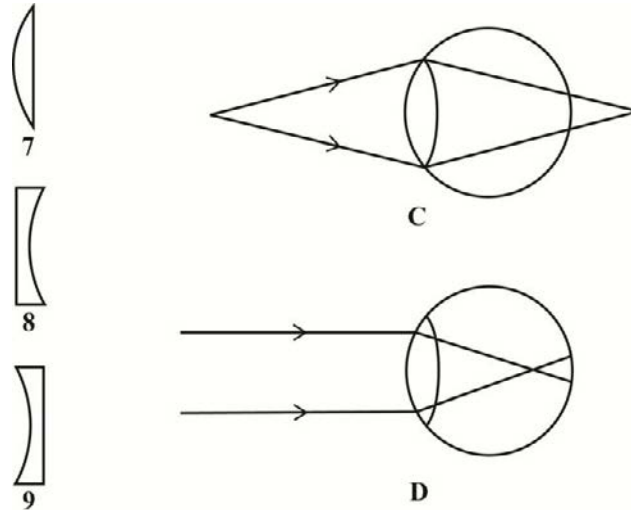

**Figure 3. Common eye defects and corrective lenses**

Identify the eye defects and the lenses in Figure 3 that can be used to correct the defects.

Diagram C Eye defect:

---

Corrective lens:

---

Diagram D Eye defect:

---

Corrective lens:

---

**(4 marks)**



- (ii) Sometimes contact lenses are used to correct eye defects. Suggest TWO precautions one should take when using contact lenses.

---

---

(2 marks)

**Total 15 marks**

3. (a) Figure 4 shows two flowers, each from two different plant species.

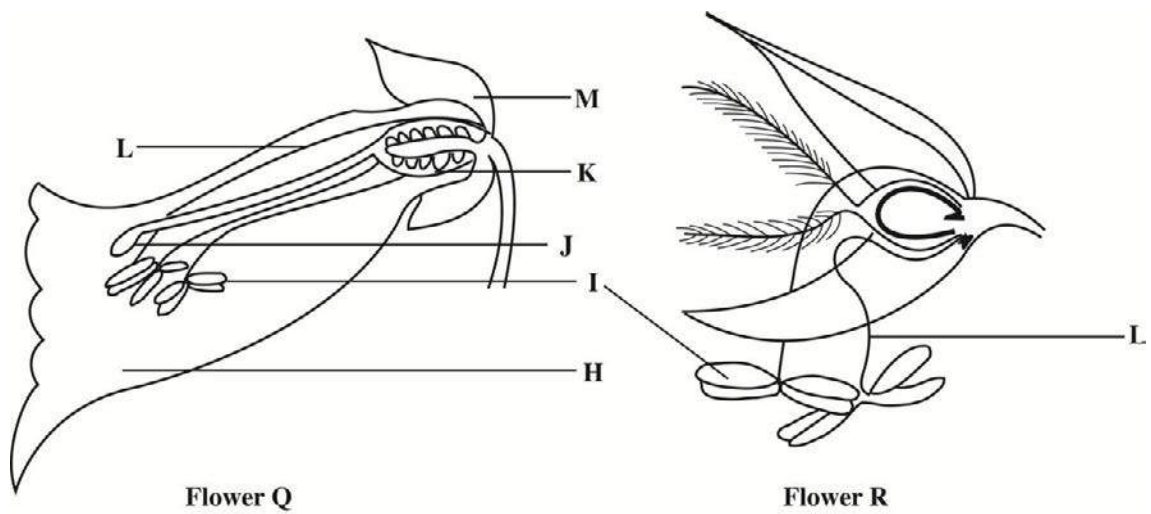

**Figure 4. Sections of flowers from different species**

- (i) Identify the parts of the flowers, labelled H to M.

H \_\_\_\_\_

I \_\_\_\_\_

J \_\_\_\_\_

K \_\_\_\_\_

L \_\_\_\_\_

M \_\_\_\_\_

(3 marks)

(ii) a) What is the likely pollinating agent of Flower R?

---

**(1 mark)**

b) Based on the information in Figure 4, give TWO reasons for your answer.

---

---

---

---

**(2 marks)**

(iii) Describe ONE characteristic of the mature fruit of Species Q that can be deduced from the diagram, and say why it is important for the survival of the species.

---

---

---

**(2 marks)**

(iv) The seeds from the mature fruit of Flower Q are not dispersed by animals or water but are found far away from the parent plant. Explain how this is possible.

---

---

---

**(2 marks)**

- (v) Suggest ONE reason why some plants have no dispersing seeds.

---

---

**(1 mark)**

- (b) Describe the events which result in the development of a seed, after pollination.

---

---

---

---

---

---

**(4 marks)**

**Total 15 marks**



**SECTION B**

**Answer ALL questions.**

**Write your answers in the spaces provided at the end of each question in this booklet.**

- 4. (a) (i) Describe the mechanisms by which air is moved into the lungs during inhalation in humans.  
  
(ii) Why is gaseous exchange important in the human body?  
  
**(6 marks)**
  
- (b) Compare the characteristics of the structures involved in gaseous exchange in humans and in flowering plants. You must state the name of EACH of the structures.  
  
**(5 marks)**
  
- (c) Explain TWO ways in which smoking tobacco may reduce the efficiency of gaseous exchange in the lungs.  
  
**(4 marks)**

**Total 15 marks**

**Write your answer to Question 4 here.**

---

---

---

---

---

---

---

---

---

---



















TEST CODE **01207032**

**FORM SPEC 01207032/2015**

**C A R I B B E A N E X A M I N A T I O N S C O U N C I L**

**CARIBBEAN SECONDARY EDUCATION CERTIFICATE<sup>®</sup>  
EXAMINATION**

**BIOLOGY**

General Proficiency

**Paper 032 – Alternative to SBA**

*2 hours 10 minutes*

**SPECIMEN PAPER**

**READ THE FOLLOWING INSTRUCTIONS CAREFULLY.**

- 1. Answer all questions.**
- 2. You are advised to take some time to read through the paper and plan your answers.**
- 3. Use this answer booklet when responding to the questions. For EACH question, write your answer in the space provided and return the answer booklet at the end of the examination.**

---

**DO NOT TURN THIS PAGE UNTIL YOU ARE TOLD TO DO SO.**

**Copyright © 2012 Caribbean Examinations Council**

**All rights reserved**

**Answer ALL questions.**

**Write your answers in the spaces provided in this booklet.**

1. (a) (i) You are provided with the following materials and apparatus:  
3 petri dishes  
A spatula  
Water  
Salt  
A piece of cucumber in a covered container  
Small knife/scalpel

**PROCEDURE**

- A. Label the petri dishes as X, Y and Z.
- B. Make a concentrated solution of salt and water, and divide it into two equal parts. Pour one half into Dish X to a height of at least 1 cm.
- Dilute the remaining half with tap water to make a solution of half the concentration of that in Dish X. Pour this solution into Dish Y. Use the same volume as you used in Dish X.
- Into Dish Z pour the same volume of tap water as used in Dishes X and Y.
- C. Cut the piece of cucumber in half as shown in the diagram below.

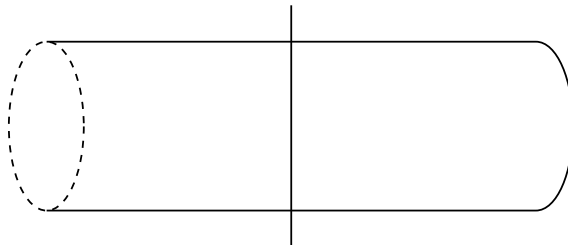

- D. Put one half of the piece of cucumber into the covered container for use in answering Part (b).
- E. Peel off the skin from the other half of the cucumber and cut THREE slices 0.5 cm thick and record your answer in Table 1 on page 3. Insert the correct headings in Table 1.
- F. Place ONE slice of the cucumber in EACH dish and leave undisturbed for at least 30 minutes.
- You may begin working on Part (b) while waiting for results from Part (a).**
- G. Remove the slices and dry them by patting gently between two sheets of paper. Record in Table 1 any changes in the size, appearance or texture of the slices in EACH solution.

**TABLE 1: RESULTS OF EXPERIMENT**

**(9 marks)**

- (ii) Describe how you made up the solution that was put in Dish Y, to the required concentration.

---

---

---

**(2 marks)**

- (iii) State the control and the manipulated variable in the experiment.

Control variable:

---

Manipulated variable:

---

**(2 marks)**

- (iv) Explain fully the differences noted between the slices in Dish X and Dish Z after 30 minutes.

---

---

---

---

---

**(2 marks)**

- (v) State ONE conclusion that could be drawn about the effect of the concentration of a solution on plant tissues.

---

---

---

**(2 marks)**

- (vi) Suggest THREE ways in which the experiment could be improved to provide more accurate data to support the conclusion drawn in (v) above.

---

---

---

**(3 marks)**

- (b) Remove the second piece of cucumber from the closed container.  
Make a large labelled drawing to show the CUT END ONLY of the cucumber.

Diameter of cut end: \_\_\_\_\_

Magnification: \_\_\_\_\_

**(8 marks)**

**Total 28 marks**

2. A Biology class carried out an investigation of the amount of water lost from two plants species over a 10-hour period. The two potted plants were kept in the laboratory under very dim light and were weighed at hourly intervals after the initial masses were obtained. The change in mass of each plant was recorded and used to calculate the percentage water-loss, shown in Table 2.

**TABLE 2: PERCENTAGE WATER-LOSS PER UNIT AREA IN TWO PLANT SPECIES OVER A 10-HOUR PERIOD**

Time(hour)	Percentage Water-loss	
	Species P	Species Q
0	0.0	0.0
1	5.0	9.0
2	8.5	11.0
3	11.0	12.5
4	12.0	14.0
5	13.5	15.0
6	13.5	16.5
7	14.0	17.0
8	14.5	18.5
9	14.5	20.0
10	15.0	22.0

- (a) Represent the data collected on the two plant species on the following grid.

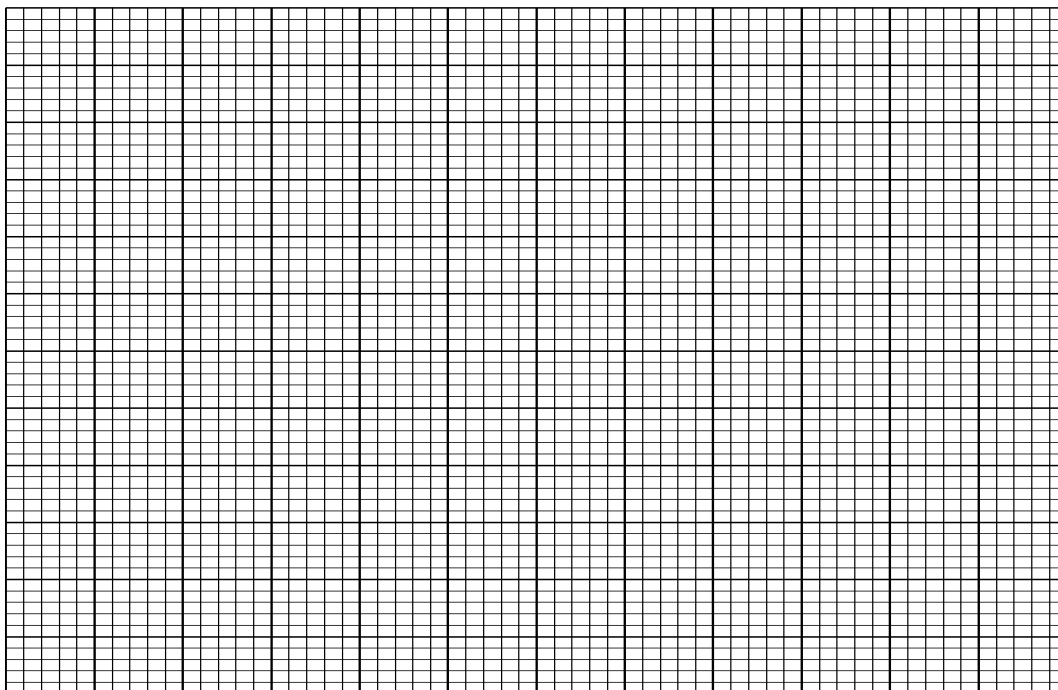

(8 marks)

(b) Suggest TWO sources of error in the investigation.

---

---

**(2 marks)**

(c) Explain the differences observed in the percentage of water lost from the two plant species over the 10-hour period.

---

---

---

---

**(2 marks)**

(d) The apparatus shown in Figure 1 were used to collect the data for the investigation of water-loss in the two plant species.

In the box provided on page 8, illustrate how the apparatus shown in Figure 1 were arranged to collect the data in Table 2.

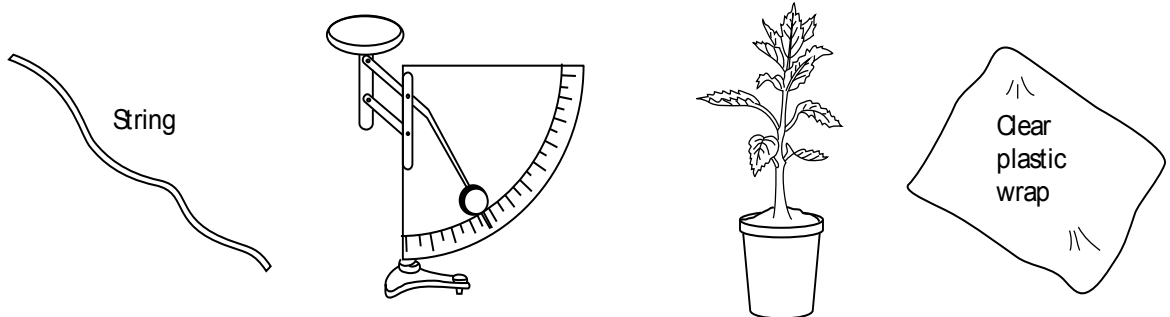

**Figure 1. Apparatus and materials used to determine water-loss in two plant species**



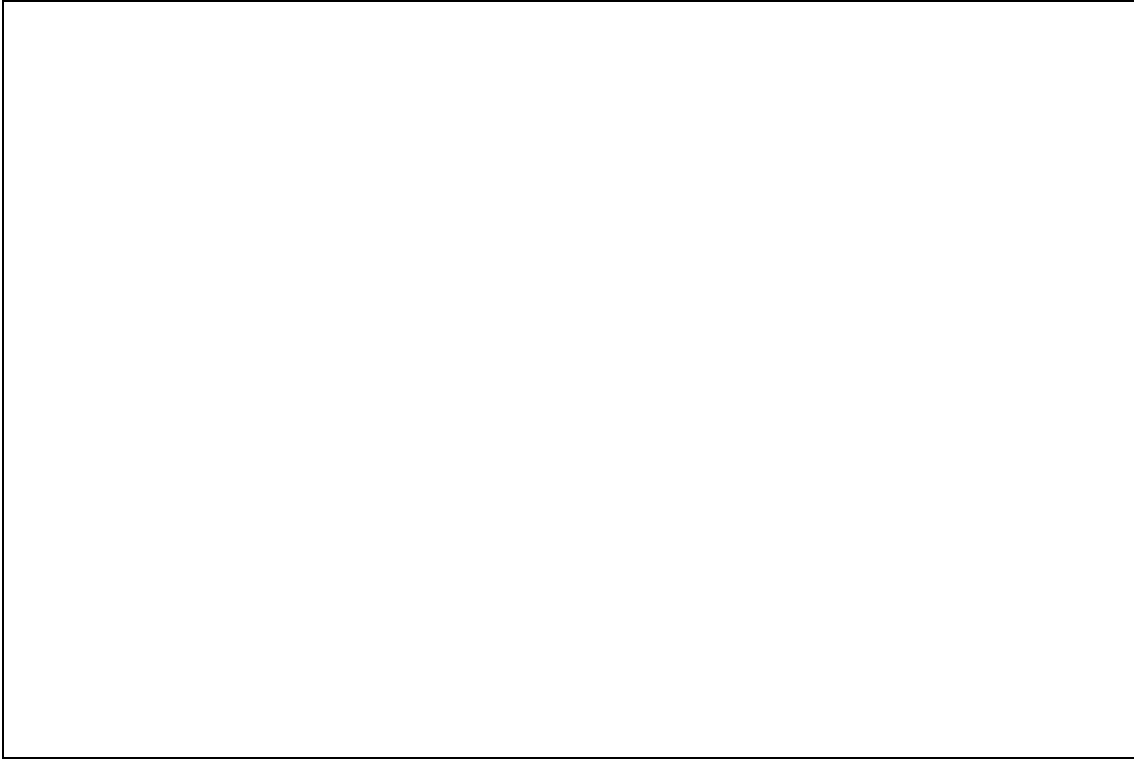

**(3 marks)**

(e) Suggest TWO adaptations that a plant may have to conserve water.

---

---

---

**(2 marks)**

**Total 17 marks**

3. (a) (i) In the space below, draw a surface view of the apparatus and materials in Figure 2, to show how an investigation into the response of invertebrates to differences in light intensity could be set up.

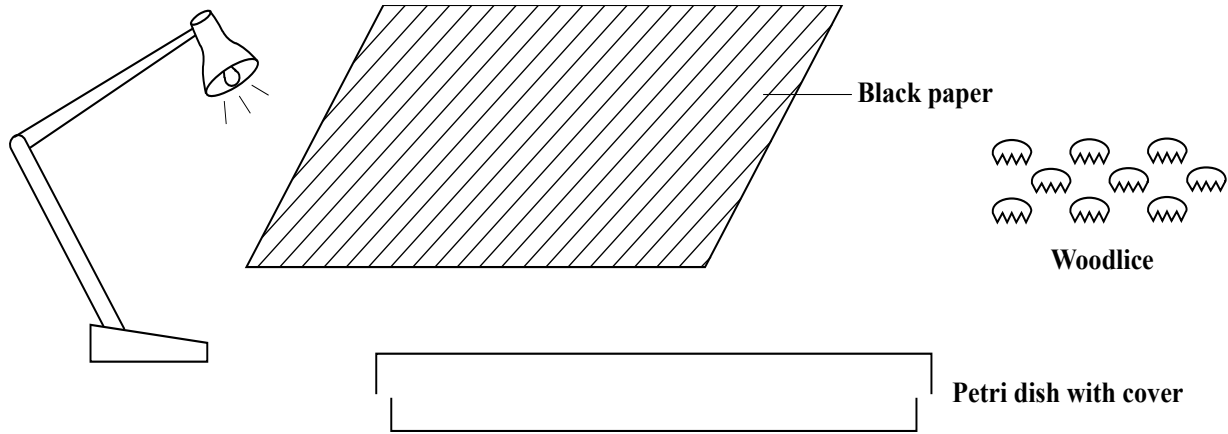

**Figure 2. Apparatus and materials for the investigation**

**(2 marks)**

- (ii) State TWO precautions that should be taken when handling live animals to ensure their safety.

---

---

---

---

**(2 marks)**

(iii) State TWO limitations of this investigation.

---

---

---

---

**(2 marks)**

(iv) Describe the actual observations a scientist may make which would lead him/her to set up this experiment.

---

---

**(2 marks)**

(v) State a hypothesis that a scientist could have used as a basis for this investigation.

---

---

**(2 marks)**

- (b) All the woodlice were placed in the centre of each of four chambers at the start of the investigation. Table 2 shows the distribution of the woodlice in the chambers at different times.

**TABLE 2: DISTRIBUTION OF WOODLICE IN THE CHAMBERS AT DIFFERENT TIME INTERVALS**

Time(min)	Conditions in Each Chamber			
	A	B	C	D
	Wet and Light	Wet and Dark	Dry and Light	Dry and Dark
5	4	14	2	10
10	3	24	1	2
20	1	28	1	0
40	0	29	1	0

- (i) To which TWO conditions were the woodlice responding positively in the first five minutes?

---

---

**(2 marks)**

- (ii) Which TWO conditions did the woodlice seem to avoid?

---

---

**(2 marks)**

- (iii) Given the results after 40 minutes, suggest ONE natural habitat in which woodlice are likely to be found.

---

**(1 mark)**

**Total 15 marks**

**END OF TEST**

**CSEC BIOLOGY**

**Specimen - Paper 01**

**2015**

<b>QUESTION NUMBER</b>	<b>KEY</b>	<b>SYLLABUS OBJECTIVE</b>
1	A	A1.1
2	D	A2.1
3	B	A3.3
4	B	A3.7
5	A	A4.1
6	C	A7.1
7	D	B1.3
8	B	B1.3
9	C	B1.4
10	B	B2.8
11	C	B2.9
12	D	B2.2
13	A	B2.2
14	C	B2.4
15	C	B2.4
16	D	B2.11
17	C	B2.7
18	A	B3.1
19	C	B3.2
20	B	B3.3
21	A	B3.3
22	A	B3.3
23	B	B4.3
24	C	B4.3
25	C	B4.6
26	D	B4.9
27	B	B5.4
28	C	B5.4
29	B	B5.4
30	A	B6.1

<b>QUESTION NUMBER</b>	<b>KEY</b>	<b>SYLLABUS OBJECTIVE</b>
31	C	B6.4
32	B	B7.8
33	B	B7.6
34	B	B7.6
35	A	B7.5
36	B	B7.8
37	A	B7.11
38	C	B9.3
39	C	B7.2
40	A	B8.3
41	A	B8.1
42	C	B8.2
43	D	C9.1
44	D	C9.1
45	C	B9.2
46	C	B9.2
47	C	B9.2, 9.3
48	A	B9.5
49	A	B9.9
50	C	C4.7
51	D	C2.2
52	A	C2.1
53	D	C1.2
54	A	C3.1
55	D	C4.4
56	C	C4.10
57	B	C5.1
58	B	C5.4
59	D	C6.1
60	A	C7.1

C A R I B B E A N      E X A M I N A T I O N S      C O U N C I L

CARIBBEAN SECONDARY EDUCATION CERTIFICATE®  
EXAMINATION

BIOLOGY

PAPER 02 - GENERAL PROFICIENCY

MARK SCHEME

SPECIMEN PAPER 2015

## BIOLOGY

## PAPER 02 - GENERAL PROFICIENCY

## SPECIMEN

## MARK SCHEME

<u>Question 1.</u>	KC	UK	XS
<p>(a) (i) Rope/String Tape measure Bottles Traps Any other reasonable suggestion</p> <p><b>Any 2 = 2 marks</b></p> <p>(ii) <u>Rope/String</u> Use a line transect Secure the rope at one end of the habitat <b>(1)</b> Extend in a straight line to the other end <b>(1)</b></p> <p><b>Any 1 = 1 mark</b></p> <p><u>Use the tape/measure</u> to mark the transect <b>(1)</b> Record the species of plants touching the line at regular intervals <b>(1)</b></p> <p><b>Any 1 = 1 mark</b></p> <p><u>Bottles/traps</u> - laid along transect lines/pitfalls for catching mobile organisms (small/large)</p> <p><b>Any 1 = 1 mark</b> <b>Max mark = 2</b> <i>Explanation to include how the apparatus will be used</i></p>			2
<p>(b) (i) Throw the quadrat randomly Repeat throws</p> <p><b>Any 1 = 1 mark</b></p> <p>(ii) Sum all the quadrat results = 22 <b>(1)</b> Divide by 10 Species density = 2.2 shrubs/m<sup>2</sup> <b>(1)</b></p>			1
<p>(c) (i) <u>Food web</u></p> <p>Producer <b>(1)</b> Arrows pointing in the right direction Organisms used in logical sequence Interconnected food chains shown</p> <p><b>Any 2 = 2 marks</b></p>			3

## BIOLOGY

## PAPER 02 - GENERAL PROFICIENCY

## SPECIMEN

## MARK SCHEME

<u>Question 1. (continued)</u>	KC	UK	XS
(c) (ii) Less energy available at higher trophic levels Energy lost at each successive trophic level Respiration activity, excretory losses at each level Competition for food  <b>Any 1 explained = 2 marks</b>	2		
(ii) Temperature Turgidity Rainfall  Any other reasonable suggestion  <b>Any 2 = 2 marks</b>	2		
(d) (i) <u>Line graph</u> : (see graph on Page 5) Title <b>(1)</b> Axis labeled appropriately <b>(1)</b> Accurate plot <b>(2)</b> - scale - all points accurate  (ii) Decline before hurricane <b>(1)</b> Limited availability of food Killed by vehicles/humans Use of insecticides  <b>Any 1 = 1 mark</b>  Increase after the hurricane <b>(1)</b> Pond expands due to rainfall More tadpoles/increased fertility  <b>Any 1 = 1 mark</b>  Decline after the hurricane <b>(1)</b> Competition Limited availability of food Killed by vehicles Use of insecticides Destruction of habitat by man  Accept any other reasonable explanation  <b>Any 1 = 1 mark</b>			4
		3	



## BIOLOGY

## PAPER 02 - GENERAL PROFICIENCY

## SPECIMEN

## MARK SCHEME

<u>Question 1. (continued)</u>	KC	UK	XS
<p>(d) (iii) Good indicator species Population changes in frogs indicate changes in the environment</p> <p>Frog population will change with the:</p> <ul style="list-style-type: none"> <li>- amount of food available</li> <li>- the number of predators in the ecosystem</li> <li>- the suitability of the habitat for the survival of the organisms</li> <li>- their numbers give an indication of how well the ecosystem is doing</li> </ul> <p>Any other reasonable suggestion</p> <p><b>Any 1 explained = 2 marks</b></p>		2	
<p>(iv) - Geographic isolation - organisms from one population spreading into the other</p> <ul style="list-style-type: none"> <li>- No gene flow between them /separate gene pools</li> <li>- Separate mutations and selections taking place so both populations become genetically different</li> </ul> <p>Any reasonable suggestion</p> <p><b>Any 1 explained = 2 marks</b></p>		2	
<p><b>Specific Objectives: A. 1.3, 2.1, 3.5, 2.3, 7.1; B. 4.10; C. 1.2</b></p>			
	4	12	9

## BIOLOGY

## PAPER 02 - GENERAL PROFICIENCY

## SPECIMEN

## MARK SCHEME

Question 1. (continued)

Graph for Question 1. (d) (i)

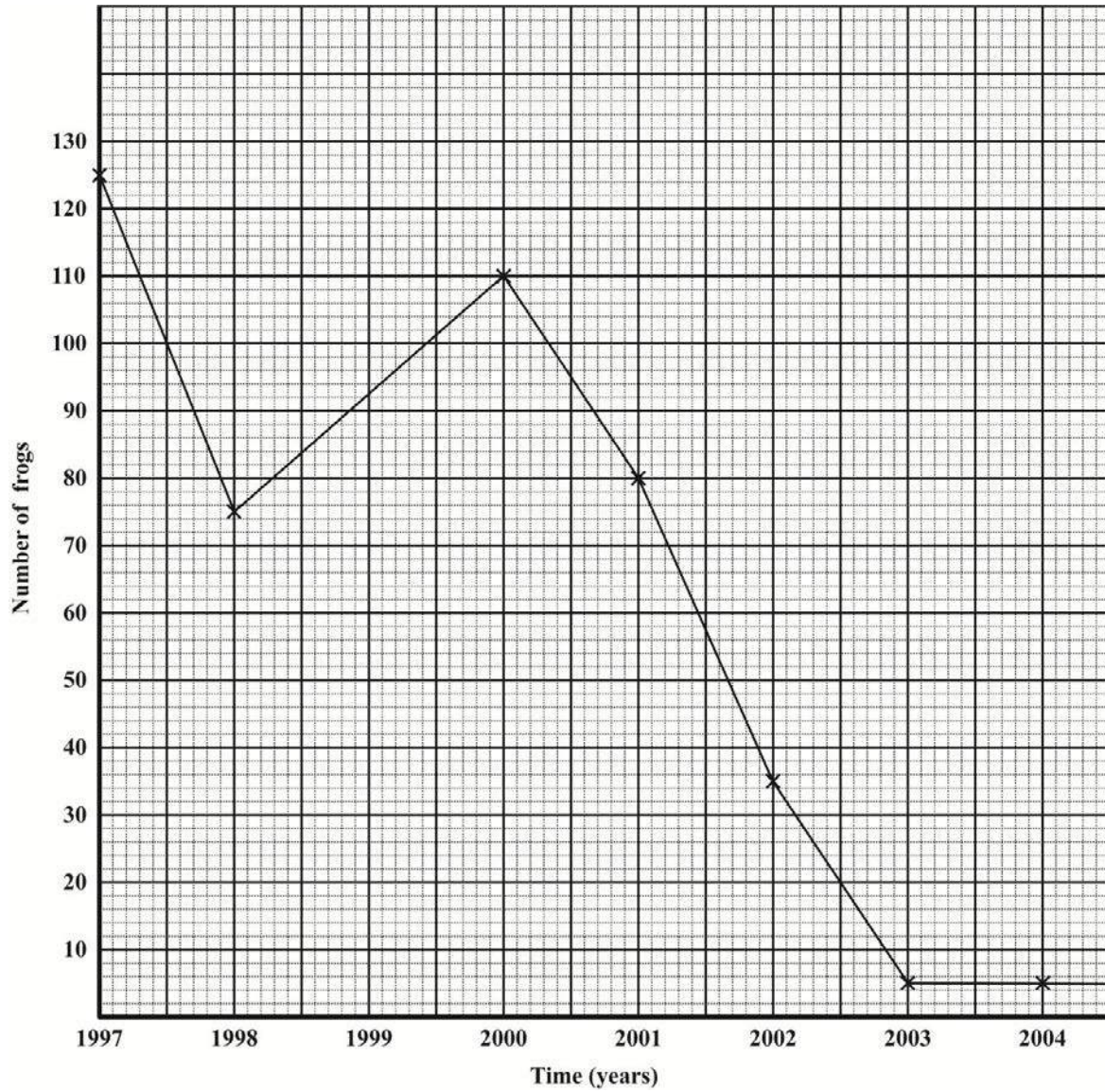

## BIOLOGY

## PAPER 02 - GENERAL PROFICIENCY

## SPECIMEN

## MARK SCHEME

<b>Question 2.</b>	<b>KC</b>	<b>UK</b>
(a) 1      Suspensory ligament 2      Lens 3      Iris 4      Ciliary muscle 5      Fovea (Yellow spot) 6      Optic nerve	6	
<b>1 mark each</b>		
(b)            Receptors/sense cells <b>(1)</b>	1	
(c)            • Passage of light through cornea blocked • Cornea needs to be transparent • Could cause blindness /impaired vision  <b>Any 2 = 2 marks</b>		2
(d) (i)        C      long sightedness/far D      short sightedness/near  7 - C 8 - D		4
(ii)           - Remove lenses from eyeball from time to time - Wash in antiseptic lotion - Wash hands before applying  Any other reasonable suggestion  <b>Any 2 = 2 marks</b>		2
<b>Specific Objectives: B. 7.9, 2.11, 7.10</b>		
	7	8

## BIOLOGY

## PAPER 02 - GENERAL PROFICIENCY

## SPECIMEN

## MARK SCHEME

<u>Question 3.</u>	KC	UK
<p>(a) (i) H - Petals I - Anther J - Stigma K - Ovary L - Filament M - Sepal</p> <p><b>6 correct = 3 marks</b> <b>4-5 correct = 2 marks</b> <b>2-3 correct = 1 mark</b></p> <p>(ii) a) Wind <b>(1)</b></p> <p>b) - Feathery stigma - Reduced/no corolla - Long filaments</p> <p>Any other reasonable suggestions</p> <p><b>Any 2 = 2 marks</b></p> <p>(iii) Many ovules visible so several seeds will be present in the fruit, increasing chances of survival of offspring <b>(2)</b></p> <p>(iv) Self-dispersal/mechanical or explosive mechanism releases seeds far away from origin <b>(2)</b></p> <p>(v) Reproduce asexually <b>(1)</b></p> <p>(b) - Pollen germinates on stigma - Pollen grain nucleus divides into 2 male nuclei - Pollen tube forms - Pollen tube grows down the style - Pollen tube carries 2 male nuclei - Pollen tube enters micropyle - Nuclei fuse with ovum/fertilization - Embryo develops - Seed store/cotyledon</p> <p><b>Any 4 = 4 marks</b></p>	<p>3</p> <p>1</p> <p>2</p> <p>2</p> <p>2</p> <p>1</p> <p>4</p>	<p></p> <p>1</p> <p>2</p> <p>2</p> <p>1</p> <p></p> <p></p>
<b>Specific Objectives: B.9.7 - 9.11</b>	<b>7</b>	<b>8</b>

## BIOLOGY

## PAPER 02 - GENERAL PROFICIENCY

## SPECIMEN

## MARK SCHEME

<u>Question 4.</u>	KC	UK
<p>(a) (i) Inhalation</p> <ul style="list-style-type: none"> <li>- Rib cage raised up and out</li> <li>- Intercostal muscles contract</li> <li>- Diaphragm contracts/flattens</li> <li>- Volume inside lungs increases, pressure inside lungs decreases</li> <li>- Air pulled in</li> </ul> <p><b>Any 4 = 4 marks</b></p>	4	
<p>(ii) - Allows oxygen from air to get into blood; oxygen is required for aerobic respiration</p> <ul style="list-style-type: none"> <li>- Removes carbon dioxide from blood</li> </ul> <p><b>Any 2 = 2 marks</b></p>		2
<p>(b) Humans - alveoli Flowering plants - leaves</p> <p><b>1 mark each</b></p> <p><u>Similarities:</u></p> <ul style="list-style-type: none"> <li>- Thin</li> <li>- Large surface area</li> <li>- Moist</li> <li>- Transport system</li> </ul> <p><u>Differences:</u></p> <ul style="list-style-type: none"> <li>- Gases travel across membrane in humans while in plants gases diffuse along a concentration gradient in air spaces.</li> <li>- In humans, blood take gases to and from the surface while in plants gases move by diffusion away from the surface.</li> </ul> <p><b>Any 3 = 3 marks</b> (must include both similarity and difference)</p>	2	3
<p>(c) Cigarette smoke:</p> <ul style="list-style-type: none"> <li>- Breaks down walls of alveoli</li> <li>- Reduces surface area for gas exchange</li> <li>- Reduces moisture lining alveoli wall</li> <li>- Makes breathing difficult</li> <li>- Reduces oxygen available for diffusion</li> </ul> <p>Any other reasonable suggestion</p> <p><b>Any 4 = 4 marks</b></p> <p><b>Specific Objectives: B.3.3, 3.4, 3.5</b></p>		4
	6	9

## BIOLOGY

## PAPER 02 - GENERAL PROFICIENCY

## SPECIMEN

## MARK SCHEME

<u>Question 5.</u>	KC	UK
<p>(a) (i) Name of pathogen - Plasmodium, dengue virus, yellow fever virus, West Nile virus <b>(1)</b></p> <p>Name of disease - malaria, dengue, Yellow fever West Nile fever <b>(1)</b></p> <p><u>Role in transmission</u></p> <ul style="list-style-type: none"> <li>- Bites infected person</li> <li>- Hosts pathogen</li> <li>- Mosquito not affected by pathogen</li> </ul> <p><b>Any 4 = 4 marks</b></p> <p><u>Social Implications</u></p> <ul style="list-style-type: none"> <li>- Loss of productivity</li> <li>- Isolation of infected persons</li> <li>- Increased demand on human services</li> </ul> <p>Any other reasonable suggestion</p> <p><b>Any 2 = 2 marks</b></p>	<p>2</p> <p>4</p> <p>2</p>	<p></p> <p></p> <p>2</p>
<p>(b) <u>Adult</u></p> <p>Breeding in stagnant water - removing stagnant water prevents breeding site</p> <p>Feeding pattern - feeds at dusk so take measures to prevent contact, for example, spraying insecticide or using repellent</p> <p><b>1 explained = 2 marks</b></p> <p><u>Eggs</u></p> <p>Eggs produced in stagnant water - prevent formation or drain stagnant pools of water <b>(1)</b></p> <p><u>Larva/Pupa</u></p> <p>Live in stagnant water - chemicals can be used to destroy them</p> <p>Small fish feeds on this stage</p> <p>Oil on surface of water prevents air getting to pupa</p> <p><b>Any 1 explained = 2 marks</b></p>		<p>5</p>

## BIOLOGY

## PAPER 02 - GENERAL PROFICIENCY

## SPECIMEN

## MARK SCHEME

<u>Question 5. (continued)</u>	KC	UK
<p>(c)</p> <ul style="list-style-type: none"> <li>- Passive/Active immunity</li> <li>- Antibodies present from vaccine/previous infection</li> </ul> <p>Any other reasonable suggestion</p> <p><b>1 mark each</b></p> <p><b>Specific Objectives: B.4.6, 8.4, 10.2, 10.3, 10.5</b></p>		2
	6	9

## BIOLOGY

## PAPER 02 - GENERAL PROFICIENCY

## SPECIMEN

## MARK SCHEME

<u>Question 6.</u>	KC	UK
<p>(a) Natural selection</p> <ul style="list-style-type: none"> <li>- Process by which allele frequency changes</li> <li>- Species better adapted to the environment</li> <li>- Environmental selection pressure</li> </ul> <p><b>Any 2 = 2 marks</b></p> <p>Genetic variation allows for differences among populations Adaptive traits passed on to the next generation</p> <p>Any other reasonable suggestion</p> <p><b>Any 2 = 2 marks</b></p>	4	
<p>(b)</p> <ul style="list-style-type: none"> <li>- Dog breeding is a form of artificial selection</li> <li>- Man selects traits considered favourable</li> <li>- Faster than natural selection</li> </ul> <p>Any other reasonable suggestion</p> <p><b>Any 2 = 2 marks</b></p>		2
<p><u>Disadvantages</u></p> <p>Traits selected by man may not allow species to adapt well/survive if environment becomes unfavourable Loss of genetic variation/density</p> <p>Any other reasonable suggestion</p> <p><b>Any 2 = 2 marks</b></p>		2





01207032/MS/SPEC/2015

C A R I B B E A N      E X A M I N A T I O N S      C O U N C I L

CARIBBEAN SECONDARY EDUCATION CERTIFICATE®  
EXAMINATION

BIOLOGY

PAPER 032 - GENERAL PROFICIENCY

MARK SCHEME

SPECIMEN PAPER 2015

BIOLOGY  
 PAPER 03/2 - GENERAL PROFICIENCY  
 SPECIMEN  
 MARK SCHEME

Question 1

	UK	XS
(a) (i) <u>Table</u> Table headings (3) Observations (6)		9
(ii) Equal amounts of tap water and the solution were mixed (1) Description of how water was measured (1)		2
(iii) Control: plain tap water (1) Manipulated variable: salt concentration (1)		2
(iv) <u>Dish X</u> - Concentration of solution outside greater than that of cucumber cell sap - Water moves out of cucumber by osmosis - Cell lose turgidity <u>Dish Z</u> - Concentration of cell sap greater than water - Water moves into the cucumber by osmosis - Cells become turgid <b>Any 2 = 2</b>	2	
(v) <u>Degree of turgidity</u> of plant tissue is related to <u>concentration of solution</u> in which it is placed. (2)	2	
(vi) - Accurate measurement of concentration - Wider range of concentrations - Use several slices - Leave for a longer time, until no further change - Different types of plant tissue must be used <b>Any 3 = 3</b>		3
(b) (ii) <u>Drawing</u> Title (1) Mag. (1) Label (3) Drawing (3)		8
<b>TOTAL</b>	<b>4</b>	<b>24</b>



BIOLOGY  
PAPER 03/2 - GENERAL PROFICIENCY  
SPECIMEN  
MARK SCHEME

Question 2 continued

- (e)      Adaptation
- Fewer stomata
  - Thick cuticle
  - Smaller leaves
- Any other reasonable suggested**
- Any 2 = 2**

	UK	XS
	2	
<b>TOTAL</b>	<b>6</b>	<b>11</b>
	UK	XS

BIOLOGY  
 PAPER 03/2 - GENERAL PROFICIENCY  
 SPECIMEN  
 MARK SCHEME

Question 3

- (a) (i) - Dish half-covered with black paper  
 - Woodlice in centre of dish  
 - Labels/title  
**Any 2 = 2**

(ii)

Precautions

- Use only slight pressure to avoid crushing them/removing limbs  
 - Keep them away from harsh/unfavourable conditions  
**Any other reasonable suggestion**  
**Any 2 = 2**

(iii)

Limitations

- One petri dish, so complete darkness not possible  
 - Woodlice may require additional stimulus to respond  
 - Difficult to maintain conditions/other physical conditions may affect woodlice  
**Any other reasonable suggestion**  
**Any 2 = 2**

(iv)

- Woodlice live in dark areas  
 - Tend to avoid light  
**1 mark each**

(v)

Hypothesis

When exposed to light woodlice move into darkened areas  
**Well stated = 2 marks**

(b) (i)

- Wet and dark  
 - Dry and dark  
**1 mark each**

(ii)

- Wet and light  
 - Dry and light  
**1 mark each**

(iii)

Under stones/litter / damp areas

**Any other reasonable suggestion**

**TOTAL**

	2
	2
	2
	2
	2
2	
2	
1	
5	10

**CARIBBEAN EXAMINATIONS COUNCIL**

**REPORT ON CANDIDATES' WORK IN THE  
CARIBBEAN SECONDARY EDUCATION CERTIFICATE**

**JANUARY 2004**

**BIOLOGY**

Copyright © 2004 Caribbean Examinations Council  
St Michael, Barbados  
All rights reserved

## **BIOLOGY**

### **CARIBBEAN SECONDARY EXAMINATIONS CERTIFICATE**

**JANUARY 2004**

#### **GENERAL COMMENTS**

The January 2004 examination in Biology at the General Proficiency level was the 23<sup>rd</sup> sitting of this CXC examination. The examination consisted of four papers: **Paper 01 – Multiple Choice; Paper 02 – Structured Questions; Paper 03 – Extended Essay and Paper 04 – Alternative to the SBA.** The number of candidates registered for this year's January sitting of the examination was 527.

General trends which were previously noted, were again evident at this sitting of the examination. For example: improved quality of writing was again produced in the extended essays. However, reading and interpreting questions remain problematic for most candidates and test-taking techniques continue to be inadequate. Too often candidates lost marks because of lack of attention to highlighted instructions in the questions. Candidates continue to pay insufficient attention to commonly used words with which they should be familiar. For example, the terms 'describe' and 'explain' were intended to guide them to the depth and breadth of answers required by particular questions. Candidates showed a trend of not reading the questions carefully as seen in, for example, questions where they were asked to make observations but gave descriptions instead. In addition, when asked to describe, some candidates gave explanations and found themselves repeating their answers when subsequently asked to explain. This was particularly noticeable in questions on Paper 04.

#### **PAPER 01 – Multiple Choice**

Paper 01 consisted of 60 multiple-choice items. Performance on this paper followed the trend of previous years in that this was the theory paper in which candidates performed best.

In Paper 01 topics that seemed most problematic for candidates included osmosis and diffusion; endocrine secretion; genetics; some aspects of the relationship between organisms and their environment.

#### **PAPER 02 - Structured Questions**

Paper 2 consisted of five short-answer structured questions of which the first was the data analysis question worth 30 marks. This paper tested the spectrum of skills outlined in the syllabus.



Candidates should be advised to wisely use the writing spaces provided in the answer booklet and not re-write any part of the question. They should focus directly on providing their responses succinctly in words and phrases in the limited spaces provided.

### Question 1

Question 1 tested a range of experimental skills associated with investigating water absorption rates in transpiring plants. Among the skills candidates were expected to demonstrate in their responses were means of representing and interpreting data and planning and designing investigations to achieve specific aims. Candidates were generally able to convert data from tabular to graphical form but were often weak in planning and designing investigations from selected materials and apparatus and in using biological concepts and principles to explain phenomena. Therefore, overall performance of candidates on this question was fair with the mean for the question at approximately 12.53.

Part (a): candidates were required to examine the results of an experiment to estimate the rate of transpiration and answer a number of relevant questions. These questions required a description of the water absorption rate over the period of the investigation, identification of the environmental factor likely to be responsible for the changes and how such an investigation would be set up given the apparatus. Candidates generally gave a good description of the water absorption rate required in (a) (i) noting the slow start of the process at the beginning of the day increasing to the highest rates in the afternoon followed by a lowering of the rate towards night. A few candidates had the misconception that the higher rate was in the morning when the reverse was the case. While candidates were generally able to identify the environmental factor that was likely to be responsible for the change in water absorption rate required in part (a) (ii), few candidates were able to provide a reason for identifying sunlight. Candidates were generally unable to link the significance of the reduction in the rate after noon and the role of the stomata in transpiration and water absorption. Performance in part (a) (iii) was unsatisfactory. Few candidates were able to show how the apparatus could be used for a simple investigation in transpiration even though all relevant materials and apparatus were given in diagrammatic form.

Candidates knew the first step which was to put the water and the twig in the measuring cylinder. The majority, however, were unaware of the purpose of the oil and incorrectly suggested the following: “place the oil on the leaf surfaces/twig base; cut the twig in two; place one in the oil and the other in the water”. In addition, most candidates failed to mention that the apparatus should have been placed in sunlight when set up.

Part (a) (iv) required two precautions when setting up the investigation. Here, as in several investigations presented in similar questions on previous papers, candidates interpreted precautions in terms of themselves and not the investigation. Some candidates mentioned not damaging the leaves, but by and large candidates failed to mention cutting the twig underwater or other condition that would adversely affect the investigation and to which the term 'precautions' would refer. It was noted that several candidates mentioned that the twigs should have no spines which they did not recognise as a characteristic of a species.

Part (a) (v): candidates were required to indicate the difference the presence of roots on the twigs might have on the processes under investigation. While candidates often felt that roots would have enhanced water absorption, they were unable to make the link with the increased surface area to volume ratio and simply stated that it was a function of roots. It is reiterated here that the study of biology must include as a major tenet the relationship between structure and function. *The essence of the study of any structure of an organism must be in relation to how that structure enables the function to be effectively and efficiently carried out.* Part (a) (vi) asked candidates to describe the type of soil that would be ideal for plants that require a good supply of water. It was expected that candidates would have used their knowledge of soil particle size, pore spaces and water-holding capacity in their descriptions. Candidates often identified a soil type loam or clay without giving its description and were thus unable to gain full marks.

Part (b): candidates were required to use data provided in tabular form to construct graphs and to interpret and account for trends shown in the graphs. Most candidates were able to correctly and appropriately plot the graphs of water absorption rate at specific wind velocity and relative humidity over a specified period of time required in part (b) (i), and more often than not gained all available marks for this section. Candidates were often able to gain the relevant mark awarded to (b) (ii) which asked for one disadvantage of conducting the investigation on water absorption outdoors and for (b) (iii) which asked a similar question for conducting the investigation on factors that influence water absorption indoors. One response to the latter question which was mentioned by no candidate, but which should be noted, is the difficulty (potential inaccuracy) in making decisions based on observations of plant behaviours made indoors.

Part (b) (iv): several candidates noted the steady increase in transpiration rate throughout the period of the investigation at the specified wind velocity, while it increased only for the first five hours at the specified humidity. However, far too many candidates felt that it was the wind speed increasing rather than the water absorption rate. Candidates had even greater difficulty responding accurately to part (b) (v) in which they

were asked to account for the response to relative humidity. Very few candidates mentioned the concentration of water inside the plant becoming similar to the concentration of water vapour in the atmosphere outside the plant after the 5th hour and no one mentioned the term 'equilibrium'.

Part (c): this question tested candidates' ability to manipulate the design of the investigation to meet specific aims as well as their understanding of water relations in plants. Part (c) (i) required an identification of three factors to be considered if one wanted to repeat the experiment to test accuracy. This simply required candidates to identify the variables in the investigation and those conditions that must be kept similar. In part (c) (ii) candidates were asked why water absorption was used to estimate transpiration rate in the investigations. One major misconception of candidates was that the amount of water transpired was determined by the amount of water absorbed. This indicated a major flaw in their conceptualization of the role of transpiration in facilitating water uptake, that is, ***water lost by transpiration will cause water absorption*** and not the other way around. Further, many candidates could not offer a sound explanation for the water being absorbed by the plant not being the same as that transpired. Candidates were expected to indicate that water is used by the plant for processes such as photosynthesis as well as forms part of the plant's structure e.g. cells.

## Question 2

This question tested candidates' knowledge of cellular structure and specialisation characteristics. Candidate performance on this question was fair.

Part (a) required candidates to label an unspecialised plant cell and to identify ways in which the cell would be adapted to suit certain functions. Part (a) (i) was well done as most candidates could identify at least two main parts of the unspecialised plant cell. However, candidates need to pay attention to spelling basic terms like 'nucleus' and to ensure that the label lines touch the structure being identified. Also, candidates should adhere to the convention on drawing biological drawings and avoid using arrows for labelling. Part (a) (ii) was also well done, as candidates were generally able to give three ways in which the unspecialised cell would be different from an animal cell. Part (a) (iii) was not as well done. In this question candidates were to give two ways in which the unspecialised cell was different from a light-absorbing cell. Many candidates identified the presence of chloroplasts (some stated chlorophyll), but few mentioned starch grains, one of the expected responses. Too many candidates incorrectly identified the presence of mitochondria and glycogen as distinguishing features. Part (a) (iv) was fairly well done with a large number of candidates correctly identifying the layer as palisade or mesophyll.

Part (b): candidates were required to use their knowledge of the events involved in cell specialisation in plants as occurs in the region behind the root and shoot tips as well as their knowledge of the need for cell specialisation and division of labour in multicellular organisms. In part (b) (i) candidates were asked to explain the changes that the unspecialised cell would have to undergo to become a water-carrying cell. Performance on this question was very unsatisfactory. Many candidates gave very simplistic responses that showed little understanding of the processes involved in growth and development in plants. Some referred to increase/decrease in vacuole size to hold water, others described the root hair and generally described one change. Candidates were expected to identify the characteristics of xylem vessels that facilitate the transport of water. These included *elongation to form hollow tubes, loss of cross walls, death of cell contents and lignification of the walls*. Part (b) (ii) seemed even more challenging to candidates and most were unable to determine the consequences to a multicellular organism of having only one type of cell. Candidates simply responded by stating that this was not possible or that the organism would die, and failed to indicate reasons why, such as, *difficulties with transport, loss of efficiency, slower reaction rates, no division of labour or specialisation*. One candidate wrote the following comprehensive response:

*...having only one type of cell means that each function of the body would not be carried out efficiently and there would be confusion between the cells and reactions would not take place when they are supposed to. The cells would become less efficient and they may die in multitasking and fighting off diseases.*

### Question 3

This question tested candidates' knowledge of the adaptations of the lungs for gaseous exchange, the differences between an artery and a vein and the differences between inhaled and exhaled air. This question was fairly well done with a mean score of 5.6 from a total of 14.

In part (a) candidates were required to identify components of the lungs on a stylised diagram. Part (a) (i): candidates were asked to identify an alveolus and most were able to do so, gaining the available mark. Candidates were less readily able to identify a bronchiole which was asked in part (a)(ii).

Part (b)(i): candidates were required to distinguish between an arteriole and a venule from cross-sectional diagrams. The majority of candidates were able to label the diagrams correctly but were hard pressed to identify the features that facilitated this identification which were the thinner wall and wider lumen of the venule compared

with the thicker wall and smaller lumen of the arteriole. In addition, many candidates did not recognise that the walls of the blood vessels consist of a fibrous outer layer and a muscle and elastic inner layer.

Part (b)(ii): candidates were asked in a) to identify two other components of the circulatory system aside from those illustrated in the diagram (arteries and veins). Too many candidates referred to parts of the heart such as the atria and ventricles and failed to name capillaries or blood constituents. Candidates failed in b) to give a satisfactory explanation for why the circulatory system was made up of different types of structures. It is very clear that candidates did not understand that *the circulatory system consisted of different structures to control the rate of blood flow to and from parts of the body*. Poor responses included: 'different structures have different functions, thus making the system function efficiently' and 'so that not just one organ would withstand the pressure.'

Part (c) examined candidates' knowledge of the characteristics of lungs that make them efficient and differences between exhaled and inhaled air. Part (c) (i): candidates were asked for three lung characteristics that make it suited to its function. Although this is quite a common question and one which also underscores the relationship of structure to function, many candidates were unable to grasp this idea. It should thus be stressed to biology students that a structure, like the lung, which has as its primary function the diffusion of substances must bear characteristics of *large surface area to volume ratio, thin walls, rich blood supply and moist surface*. Part (c) (ii): candidates were asked to compare the composition of inhaled and exhaled air. Performance on this question was unsatisfactory. Many responses merely mentioned that inhaled air contained oxygen and exhaled air contained carbon dioxide, but no comparison was made. In fact it should be noted that both inhaled and exhaled air contain oxygen and carbon dioxide and it is the relative proportion of these elements in the two types of air that distinguishes them. Other misconceptions in this question included: 'inhaled air is oxygen' and 'exhaled air is carbon dioxide'.

#### Question 4

This question examined candidates' knowledge of cell division in plants and aspects of response in plants and animals. Performance on this question was also fair with a mean of approximately 6 where the total score was 16.

Part (a) examined mitosis in plant cells. Candidates were given stimulus material which showed different stages in cell division in a plant and in (a)(i) were asked to identify the type of cell division illustrated and in (a)(ii) to place the stages in correct sequence. While many candidates were able to correctly identify the type of cell division as mitosis, they were unable to place the stages in the correct sequence showing



that the process of mitosis was not clear to them. In part (a)(iii) candidates were asked to give a characteristic of a cell produced by mitosis. This was fairly well done although many candidates used terms like 'haploid' and 'diploid' when they were quite unclear about their meanings. In part (a)(iv) candidates were asked to identify parts of the plant where mitotic divisions would occur. This performance was disappointing. Many candidates incorrectly cited the anthers and ovaries. Other candidates were unspecific and cited the 'root' and 'stem' rather than *root tip*, *shoot tip* and/or *cambium/meristem*. For part (a)(v) in which candidates were asked to identify two plant processes in which mitosis was used, they were generally able to identify growth but few were able to again the additional mark for asexual reproduction.

In part (b)(i) the question asked for two reasons why plumules bend towards a unilateral light source. Candidates generally recognised the need for the plant to obtain light for photosynthesis but did not link this with the role of the plumule in forming the shoot and/or photosynthesising organs. For part (b)(ii) candidates were asked to explain how bending occurs in the plant. This question was fairly well done. Some candidates, however, repeated the answer given in part (b)(i). One good response was: *"Bending is caused by auxins. They accumulate in the dark side causing the plumule to grow unevenly and bend towards the light."*

Part (c)(i) required candidates to give two features of the response system in humans. This was well done with several candidates gaining the 2 available marks. Part (c)(ii) was more challenging for candidates and very few were able to obtain the 3 marks allotted. Candidates were required to explain why it was important for humans to respond differently from plants to external stimuli. Very few candidates showed an appreciation of the fact that because humans are active and mobile they encounter widely different types of environments to which they must appropriately respond to preserve their lives. This is in addition to their need to pursue prey or escape predators. One candidate wrote the following acceptable response: *"Humans move to obtain food and must escape danger. They are more active and need to be more aware of their environment."*

### Question 5

This question tested candidates' knowledge of aspects of disease spread and control. Candidate performance on this question was good with a mean score of 8 where the total was 16 marks.

Part (a) required candidates to read a table of statistics of the incidence of certain communicable diseases in the Americas and draw some conclusions about the diseases. Performance of this section was moderate as many candidates failed to draw

conclusions and attempted only to read off the statistics. Data interpretation skills demonstrated were thus rather weak and suggest the need for more emphasis to be placed on developing this skill in the classroom.

Part (b): candidates were asked to suggest why it is important to obtain data as given in the stimulus material. This part was not well done. There are several reasons for obtaining such data and candidates were expected to include among their suggestions: *for monitoring purposes /awareness of trends; for corrective/preventative measures to be taken; to reduce the potential of spread/epidemics; reduce cost of treatment by early detection; reduce loss of life/work hours.*

Part (c): candidates were asked to give two ways to control a contagious disease. Most candidates gave a response that included the use of a vaccine to prevent contraction of the disease. They could also have included means of preventing the spread of the disease such as sanitary conditions, hygiene practices and isolating patients.

Part (d) addressed issues of AIDS. In part (d)(i) candidates were asked to consider certain AIDS statistics and indicate what the figures meant. Candidates often did not give a full interpretation of the data and unwittingly lost a mark. They were expected to note that the increase in incidence was marked, rapid or doubled in a short space of time, not only that it increased. Responses for part (d)(ii) showed that almost every candidate knew ways in which the AIDS virus is spread and were able to gain all the marks for this part of the question. However, they generally believed that a cure was difficult to find because ‘no one knew where the virus came from.’ Candidates therefore need to know that the difficulty in finding a cure for the disease, aside from its peculiarities such as its mutative strength, were similar to reasons for the lack of cure of any viral disease including that *it acts at the level of the cell/gene; it requires/ responds primarily to natural defense system and the difficulty of replacing the natural immune response.* Part (d)(iii) was generally well done by candidates. They were often able to suggest two consequences of AIDS being a disease of the immune system. Candidates’ responses included *the breakdown of the body’s defence system; susceptibility to other diseases* and that *minor diseases can become very harmful.*

### **PAPER 03 - Extended Essay**

The performance on this paper showed the continuing trend of improvement and some candidates attained full marks on a number of questions. Generally candidates continue to demonstrate that they have a wealth of biological knowledge. However, several weaknesses were observed in their ability to use what they do know to construct effective responses.

Comments noted in previous reports are restated to further highlight areas of persistent weakness in candidate performance due mainly to poor test-taking techniques. Some candidates do not answer questions satisfactorily as they do not develop the points they do make. Very often they fail to give appropriate examples to illustrate their points even when asked to do so. Perhaps the most obvious weakness is that they consistently failed to select appropriate material to answer questions. It is therefore important for teachers to note that, apart from knowing biology content, candidates must also be equally well prepared to provide appropriate responses to the specific questions that they select. Further, candidates must be taught to use the guidance provided by the questions such as highlights and numbering in order to answer questions more effectively. For example, the relatedness of the sub-parts of a question can be deduced from the way the questions are numbered.

### Question 1

This question tested candidates' knowledge of energy flow through a food chain, recycling methods, natural cycles, as well as their awareness of conservation methods. Almost two-thirds of the candidate population selected this question compared to its counterpart. Candidate performance was creditable.

Part (a) required candidates to explain how energy flows through a food chain - part (a)(i), and suggest one way in which energy flow is similar to and different from the movement of carbon - part (a)(ii). Most candidates understood the role of the plant in trapping sunlight but few mentioned the conversion of light energy to chemical energy in clear terms. There was also a general understanding of the movement of food energy through the food chain. Many candidates were able to elucidate the process of the trapping of light by chlorophyll and the conversion of carbon dioxide and water to carbohydrate. They were able to make the link of herbivores feeding on plants to obtain food and carnivores feeding on herbivores in the food chain. However, it was often not clear to candidates that 'food' was really the vehicle for energy which was used up in the process(es) and the chemical elements were recycled to provide a continual supply of energy. The fate of the energy was also not very clear to candidates. They seldom mentioned the role of respiration in getting at the energy trapped in food molecules and the utilisation of that energy by organisms to do work or for growth and repair. Hence they had difficulty in citing similarities between the movement of energy and the movement of carbon for example, in the same direction or through the food chain and the difference in the fact that energy was being spent or used up while carbon using different forms would reappear to once more take up new energy.

Part (b) explored candidates' knowledge of the effects of certain conditions on decomposition as occurs in a compost heap. In part (b)(i) candidates were expected to



explain the importance of damp conditions and time on the process of decomposition. Candidates were generally unable to identify the need for moisture by decomposers to be used as a solvent for enzymes and in other metabolic processes as well as the need for time for processes to occur. As in many previous papers, many candidates included earthworms among decomposers and made reference to their need for moisture to avoid drying out.

Part (b)(ii) was generally well done. Candidates more often than not were able to identify two products of the recycling processes taking place in the compost heap.

Part (c) required candidates to apply their knowledge of aspects of natural relationships and conservation. Part (c)(i) asked candidates to suggest why a sugary solution is used in bird feeders at a nature centre that focusses on conservation. While several candidates were able to compare the sugary solution with the nectar of flowers, many others failed to make that connection referring instead to the role of birds in pollination. Part (c)(ii) was generally well done. Candidates perceived the nature centre as an aid to conservation even though a number of candidates erroneously believed that the birds were going to interbreed and create new hybrid species as a matter of course.

## Question 2

This question attempted to elicit from candidates their understanding of the effects of air pollution on humans using the contexts of heavy smoking and volcanic emissions. Part of the question also dealt with population growth and recycling of nutrients. Although less popular than its counterpart, candidate performance on this question was good with a mean score of about 9.3.

Part (a) asked candidates to discuss the likely effects on the human body of long-term exposure to volcanic emissions, given that residents in the area of an active volcano were displaying effects similar to those of heavy smokers. This part of the question was very well done with several candidates obtaining full marks. Candidates seemed familiar with the consequences of heavy smoking and were able to link the effects with those caused by pollution from the volcano. However, there were some candidates who referred to tar and nicotine and were therefore not quite distinguishing differences between the effects of the volcanic ash and cigarette smoke.

Part (b) generally sought to determine whether candidates could apply their knowledge of plants and how they function to their existence in an environment polluted from volcanic emissions. In part (b)(i) candidates were to explain how ash covering the leaves of trees might affect their functioning. Candidates were particularly adept at highlighting the reduction in photosynthesis due to reduction in the availability of

light. They were less clear about the effects on transpiration where it was expected that they would have indicated blockage to the stomata; and on the reduction in the rate of gaseous exchange. In part (b)(ii) candidates were asked to name two nutrients that were present in the emissions and give their role in the plant. Most candidates failed to give two appropriate mineral nutrients, when it was expected that they would have least been familiar with nitrogen and magnesium containing nutrients.

Part (c) explored candidates' knowledge of the factors that affect population growth and the ways in which the effects might be shown. Part (c)(i) asked candidates what would happen if the population inhabited a new confined area and growth continued unchecked. It appeared that those candidates who recognised that the question concerned overpopulation and overcrowding provided adequate responses and some gained full marks. However, several candidates confined their responses to the effects of volcanic emissions on the population and were unable to score many marks here. Part (c)(ii) built on the previous question and asked about the possibility of growth continuing indefinitely. Candidates were expected to provide one of a number of reasons for example: *growth will not continue since resources will become inadequate; subject/susceptible to disease spread and some will die.*

### Question 3

This question tested candidates' knowledge of enzymes and their properties as well as how they function in digestion. It also tested their knowledge of digestion process and the importance of nutrition in children. This was the more popular of the question pair in this section. Candidate performance on this question was fairly good with a mean score of 8.2

In part (a) of the question, candidates were asked about enzymes and their properties. While this part of the question was fairly well done a number of misconceptions held by candidates came to light. In part (a)(i) where candidates were asked to define the term 'enzyme' and to state why they are important, some candidates made erroneous claims such as "enzymes breakdown food," or "are inorganic catalysts." Other candidates failed to gain full marks for the question by stating only that "enzymes are organic catalysts" without adding further that *they are protein in nature* or are *made by living cells* and without explaining their importance by stating, for example: *without enzymes reactions would be too slow to sustain life.* In part (a)(ii) candidates were required to use examples from different parts of the alimentary system to illustrate specificity of enzymes. Candidates generally did not score well on this part of the question. Their responses mainly focussed on specificity as regards substrate. Few mentioned specificity with respect to the temperature and pH of which there are several examples along the alimentary canal. For example, as regards pH, *salivary amylase in the mouth requires an alkaline pH as opposed to pancreatic amylase.*

Part (b) of the question required candidates to explain the fate of chyme while in the duodenum. The majority of candidates were aware of the constituents of chyme and were able to identify the changes they undergo in the duodenum under the influence of enzymes, for example, *fats to fatty acids and glycerol with lipase, starch to maltose with amylase*. Mention was made of the *emulsifying of fats by bile*.

Part (c) of the question was well done. The question asked for reasons for candidate opinion about allowing children to choose what they like to eat. As expected, candidate responses included the importance of a balanced diet and problems of malnutrition and the likelihood of obesity. Surprisingly though, no candidate mentioned *the importance of certain nutrients at different stages of development*, which is an important consideration in the diet of a child.

#### Question 4

This question explored candidates' knowledge of hormones in humans; and plant growth substances. Candidates' performance on this question was comparable to that of its counterpart as evidenced by a mean score of 8.3.

Part (a) of the question tested candidates' knowledge of hormones; their importance; and their role in the development and functioning of the human reproductive organs. Candidate often did not obtain full marks for part (a)(i) because their definition of hormones stopped at "substances secreted by glands." They needed to include that they are secreted *by endocrine glands, directly into the blood stream and affected target organs*. Many candidates did not indicate the importance of hormones. Candidates were generally able to define one role for hormones including their *coordinating function; their role in development; homeostasis; maintenance or preparation for emergencies*. Part (a)(ii) asked candidates to describe the role of hormones in the development and functioning of the human reproductive organs. Few candidates included in their descriptions the role of the pituitary in activating gonads to produce sex hormones, but were well versed in describing the roles of testosterone in the male, oestrogen and progesterone in development of secondary sexual characteristics in females, as well as the roles of the latter hormones in ovulation and menstruation.

Several candidates obtained full marks for part (b) of the question which required them to explain what knowledge one needs to have to use birth control methods effectively. Candidates were particularly clear about how a condom worked and thus should be used. Their knowledge of the working of the pill and other methods was not as precise. In explaining about the pill, for instance, candidates were expected to indicate that it *contains hormones similar to those produced in the menstrual cycle and prevented release of eggs from the ovary*.

Part (c) asked candidates about plant growth substances. In part (c)(i) candidates were asked to explain the differences and similarities between plant 'hormones' and hormones found in humans. Very few candidates recognised that there are differences in where they are secreted and how they reach target sites. Candidates should have noted that plant 'hormones' are not *secreted by special glands* and they *diffuse directly to their target tissue*. Identifying similarities also posed a problem for many candidates whose response should have included the fact that *these substances control development* and that *they are produced in one site and have an effect elsewhere*. Part (c) (ii) asked candidates their opinion about spraying unripe fruit with plant growth substances. Candidates performed well on this part of the question indicating that the high concentrations may be harmful to fruit consumers. Few candidates considered a positive response such as *benefit to the farmers/retailers*.

### Question 5

This question required knowledge of the structure of the kidney and the way in which immunity in humans functions in relation to organ transplant. This question was not at all popular and the performance of candidates was very unsatisfactory. The mean for this question was approximately 2.9.

Part (a) of the question asked students to describe the arrangement of the tubules that make up the kidney. Candidates were expected to highlight the location of Bowman's capsule and convoluted tubules in the cortex, Loop of Henle and collecting duct in the medulla with the pelvis connecting to the ureter. This was a question for which candidates could have used a diagram to illustrate the relationship among the components of the kidney and in particular the gross with the fine structure. Where candidates gave illustrations, however, there was no indication of the relationship between the tubule and the kidney. Further candidates often failed to give accurate functions of the parts of the kidney and kidney tubule which they identified. Candidates have a general impression that the kidney filters out the waste but the processes, particularly reabsorption, are not clearly understood. In general performance on this part of the question was poor.

Part (b) asked candidates to explore the necessity for properly functioning kidneys and some of the risks involved in kidney transplants. Part (b)(i) was fairly well done as candidates recognised that if the kidneys do not work well *toxins could build up*; or the *osmotic balance could be difficult to attain*. Part (b)(ii) which asked candidates to relate the rejection of transplanted tissue to the immune reaction in the body was well done by a number of candidates who recognised that the transplanted kidney would be *detected as a 'foreign' antigen by white blood cells*. Many candidates did not fully explain their answer and omitted from their response the implications of being detected as a foreign antigen such as: *production of antibodies; attempt to*

*destroy kidney; inhibition of kidney function; inhibition of integration of the kidney into the body.*

In part (c) candidates were asked to whether grafting tissues in plants would meet a similar obstacle of rejection of transplanted organs in humans. Candidates perceived that the grafting process in plants was less complex than transplanting organs in humans. They generally felt that the plants were of the same species so that there would be no problem. Candidates failed to make use of thread of the question and relate their responses to the *absence of a detection system in the plants* or *absence of an immune reaction* alluded to in section (b). In part (c)(ii), candidates were asked why a grafted part of a plant may have different characteristics from the rest of the plant. Surprisingly candidates did not relate the characteristics of the plant to its genotype.

### Question 6

This question tested candidates' knowledge of the structure and function of the skeleton, plant adaptation to certain environments and plant breeding. Part (a) of the question dealt with the human skeleton and selected functions as well as support mechanisms in plants. In part (a)(i) candidates were asked to state features important in locomotion and protection and describe how these features facilitated the functions indicated. Candidates generally gained the marks for identifying skeletal features important in locomotion but failed to do so effectively for protection. Candidates were expected to describe features such as *hollow casings, dense hard bone, girdles and cages for housing delicate tissues*. Some candidates simply identified the skeletal part, such as, the ribs, without mention of the cage they formed for protection.

Part (a)(ii) was poorly done. Candidates were asked to compare the support provide by the human skeleton with the support mechanism in terrestrial plants. Responses generally showed no comparison. Some candidates repeated ideas expressed in (a)(i) which gained no marks. Candidates were expected to highlight features such as the hard, rigid bones of the human skeleton that keep soft parts in place compared with *the thick, lignified walls of xylem that provide rigidity and hold the rest the stem and leaves in place*.

In part (b) candidates were asked about the similarity between the characteristics of plants growing on a hillside and those in the desert. They were to identify two of the characteristics they would have in common and explain the similarities. Candidates' performance was fair and several of them indicated features such as: long roots for water absorption; small reduced/rolled leaves to reduce transpiration. One common misconception was that big leaves trap more sunlight.



For part (c) candidates were asked to suggest advantages and disadvantages of plant breeding programmes. This part of the question was well done. Candidates suggested advantages such as: timing of flowering, ripening of fruit, colour uniformity, increased production, disease resistance. They suggested disadvantages such as, 'large numbers could be susceptible to new disease'. Generally candidates failed to gain full marks in this section because they listed the advantages/disadvantages without an explanation.

### **PAPER 04 – Alternative to the SBA**

As the alternative to the SBA, this paper tests the practical skills that Biology students are expected to develop. Candidates are thus required to demonstrate in the examination the same range of skills as candidates writing the June examinations. Candidates' responses suggested that a significant number of them were still unfamiliar with some basic laboratory techniques, apparatus and reagents and that candidates were unable to demonstrate adequate skill in technical areas such as drawing.

#### Question 1

This question tested candidates' ability to make observations about the characteristics of leaves and to draw one leaf specimen, measure leaf area using graph/ruled paper. Candidates' performance on this question was good with a mean core of 8.5 out of 14.

Part (a) of the question required that candidates draw one leaf specimen, measure and record its length and calculate the magnification of the drawing. This question was generally well done as candidates were able to demonstrate drawing conventions including the use of clean, clear lines and with good accuracy.

Part (b) required candidates to describe how they would measure the surface area of the drawn specimen. Candidates generally understood that they could determine the leaf area by counting the squares on the graph/ruled paper. This part of the question was also well done.

In part (c) candidates were asked to identify the leaf with the larger surface area. Most candidates gained the marks allotted to this part of the question.

In part (d) candidates were required to compare the characteristics of the two leaves in tabular format. Almost all candidates were able to construct a table and enter the table contents but citing the similarities and differences between the leaves proved difficult for far too many of them. Candidates tended to limit their comparison to leaf surface area and ignore obvious features of venation, petiole and leaf shape.

## Question 2

This question required candidates to demonstrate their ability to carry out a simple investigation of the process of osmosis on cut petioles. Candidates were expected to follow instructions; make observations and illustrate changes using drawings; draw conclusions as well as describe a method for improving the investigation. Performance was only fair with a mean score of **5.4** out of a total of **12**.

In Part (a) candidates were required to make simple line drawings of cut petioles to record their appearance before an investigation in which the petioles were placed in solutions of different concentrations. Candidates generally made poor drawings in which one could not distinguish the epidermal region from the inner tissues. This was essential for effective comparison.

Part (b), was also not well done. It required candidate to make drawings of the petiole to show the appearance at the end of the investigation. Candidates often showed in their illustrations that there was some curvature of the petiole, but one could not distinguish the direction of the curvature due to the poor representations

In part (c), candidates were asked to explain the differences in appearance observed in the petioles at the end of the investigation. A fairly large number of candidates were unable to explain that *the petiole in the salt water lost water by osmosis so that the inner tissue shrank causing an inward curvature of the petiole*. Conversely, *petioles in the plain water gained water by osmosis the inner tissues became swollen causing bending outwards*.

In part (d) candidates were asked to suggest two ways in which the design of the experiment could be improved. This question was well done by candidates whose suggestions included: 'measuring the salt and water more accurately'; 'timing'; 'using different concentrations'.

Part (e) asked candidates whether the extra piece of petiole left on the desk could be considered a control. Candidates could have responded in the positive or negative, the important factor being the supporting reason. Several candidates did not feel that it could be considered a control, but were unable to give a sound reason such as: *the conditions different; water lost by evaporation*. Similarly, *if they responded in the affirmative they were often did not state that it was left in a normal state for the same length of time*.

### Question 3

This question tested candidates' knowledge of germination and the factors that affect this process. Candidate abilities in the areas of observation, data collection, presentation, analysis and interpretation were also assessed. Candidate performance on this question was good with a mean score of 21 out of 34.

Part (a) of the question required that candidates complete a table of results of a germination experiment aimed at identifying certain conditions that affect the process. In part (a)(i) candidates were required to complete total and mean germination under different conditions. While most candidates were able to accurately provide the totals, they too often had difficulty computing the means. In part (a)(ii) candidates were asked to identify two errors that could have contributed to one group obtaining results that were markedly different from the others. Few candidates did this question well. While some candidates were able to identify errors they offered no explanation as was required by the question. In response to part (a)(iii) which asked why it is advantageous to use the class means rather than individual means to draw conclusions, candidates tended to provide vague answers. The expected response included: *to limit the effect of individual variations; to improve accuracy*. For part (a)(iv) candidates were required to write the aim for the investigation. Most candidates responded well to this question by including the effects of specified conditions on germination. Candidates in part (a)(v) were asked to identify, based on the investigation, the conditions that facilitate successful germination. Most candidates were able to identify light and water. Some did not mention oxygen as should have been indicated by the results obtained with boiled water. In part (a)(vi) candidates generally had difficulty in relating the requirements identified in the previous part of the question to the life of an aquatic plant. For example, *oxygen is important for respiration and seeds will not germinate in stagnant water; seeds are light sensitive, thus, with less light under water, seedlings would germinate only near to the surface*.

Part (b) required candidates to plan an investigation to find the ideal temperature for the seeds to germinate. In part (b) (i), most candidates were able to state an appropriate aim but faltered in defining an appropriate method. Candidates were expected to consider in their method: *equal number of seeds; seeds from the same plant; same conditions; ideal conditions; unboiled water and light; temperature differences and how maintained; and appropriate control*. Part (b)(ii) required candidates to read off from illustrations of thermometers, the temperature at which germination was the fastest. Most candidates gained full marks in this exercise.

Part (c) explored candidates' ability to apply their basic biological knowledge to unique conditions. In part (c)(i) candidates were required to describe an illustration of



seedlings subjected to growth in the dark for a brief period. Many candidates failed to gain marks here because they gave a reason for what they observed rather than a description of the *observations* as the question asked. While part (c)(ii) was done much better than the previous question, several candidates repeated their response from part (c)(i). Candidates generally performed well on part (c)(iii) which required them to interpret the results of data collected from food tests on cotyledons of the seeds used in the investigation. However, they were generally unable to use the information gleaned in the food test to explain why the storage product identified was useful to the plant. Candidates were expected to relate the storage of fats to providing buoyancy since the plant grows in water.

**CARIBBEAN EXAMINATIONS COUNCIL**

**REPORT ON CANDIDATES' WORK IN THE  
SECONDARY EDUCATION CERTIFICATE EXAMINATION**

**JUNE 2004**

**BIOLOGY**

**Copyright © 2004 Caribbean Examinations Council  
St Michael, Barbados  
All rights reserved.**

## BIOLOGY

JUNE 2004

### GENERAL COMMENTS

The June 2004 examination in Biology at the General Proficiency level was the 24<sup>th</sup> sitting of this subject conducted by CXC. Biology continues to be offered at both the January and June sittings of the examinations. The biology examination is the most popular of the single sciences offered by the CXC at the CSEC level and assesses the performance of approximately 13 000 candidates annually. The examination comprised four papers: **Paper 01 – Multiple Choice; Paper 02 – Structured questions; Paper 03 – Extended essays; Paper 04 – the School Based Assessment (SBA)**. The mean score across all papers for this sitting fell below the mean for the June 2003 examination.

The overall performance of candidates in June 2004 was lower than expected, and lower than the performance in June 2003. Apart from the effects of examining a new syllabus this year, the lower performance of candidates is in part also due to a lack of attention to several suggestions which the Biology examiners have repeatedly made over the past years, and candidates' inability to display skills they are supposed to acquire in pursuing practical work. *Particular attention should be paid to these comments in preparing candidates for the examination, if the desired improvement in performance is to be realized and **sustained**.* These comments relate both to test-taking techniques and means of addressing the content of questions, and are as follows:

- In papers where limited spaces are provided for short answers, candidates should NOT **repeat the questions asked**. This leaves insufficient room and leads to the writing of responses in the margins which wastes valuable writing time.
- Candidates wasted time providing information that was irrelevant to the question, gaining no marks. This was particularly notable in Paper 3. Candidates should make better use of the time allotted for reading through the paper by selecting their questions and **planning** their responses BEFORE starting to write.
- Teachers should remind candidates that in preparing for the examination, they should do more than memorize the content. When preparing candidates for an examination, time should be spent practicing how to interpret questions and how to answer questions clearly, concisely and to the point.
- Too many candidates did **not read** the questions carefully. They should be advised to take special note of the cues given in the questions and to underline key words to focus attention on what the question requires. For example, when the question asked for TWO items many candidates gave ONE and lost marks unnecessarily through apparent carelessness.
- The manner in which a question is numbered may be used as a guide to how parts of a question are linked. Candidates should note that the numbering changes when there is a change in concept or context. They should also make every attempt to use the information given in the various parts of a question to help focus the context and content of their responses.
- Biological jargon should be used where appropriate and **spelling** of biological terms must be correct.

### PAPER 01 – Multiple Choice

Paper 1, as is customary, consisted of 60 multiple-choice items. Performance on this paper was surprisingly lower than that of June 2003. The mean for the paper was **34.32** (57 per cent) compared with 37.20 (62 per cent) in 2003.

Topics that were *most* problematic for candidates were:

- General knowledge of common chemical reactions in the body e.g. hydrolysis, oxidation, glycolysis
- Aspects of nutrition
- Aspects of respiration and excretion
- Bones and their functions
- The eye as a receptor and effector organ
- Metabolic rate and effect on the body temperature
- Distinction between meiosis and mitosis

### PAPER 02 – Structured Questions

Paper 2 consisted of five short-answer structured questions of which the first was the data analysis question worth 30 marks. This paper tested all skill areas identified in the biology syllabus. Performance on this paper was much lower than anticipated and fell below the performance in 2003.

Reports over the last few years have highlighted the need for candidates to pay attention to examination techniques when writing this paper. In particular, attention is drawn to the use of the stimulus material in responding to the questions and the guidance provided by the space allotted to each question. Candidates also continue to display weak practical skills especially in planning and designing, describing experimental methods and in drawing conclusions from data. These observations suggest that **teaching for developing practical skills must include discussions, explanations and rationalizing of procedures and outcomes on the part of students** so that they become capable of developing and manipulating experiments and experimental data on their own. Simply having students write up experiments without orally communicating what they are doing and thinking squanders the opportunity practicals provide for **teaching and learning**.

#### Question 1

Question 1 tested a range of experimental skills associated with investigating the properties of visking tubing and movement of particles across this membrane. Among the skills candidates were expected to demonstrate in their responses were means of eliciting information from an experimental procedure, interpreting data, drawing conclusions and modifying/ manipulating an experimental design using the same apparatus but different reactants. The question also required candidates to consider the components of a balanced diet presented in a chart and work out the relationships between the components. Candidate performance on this question was poor. Candidates displayed particular weaknesses in describing the method of the experiment illustrated; explaining the events of the experiment that the apparatus illustrated; and were unable to modify the procedure for a similar type of investigation. *Teachers are thus advised that their students should not only be required to write up experiments in the conventional scientific format, but must also be able to explore the experimental procedures and outcomes to ensure understanding and to determine outcomes of adjusting the experimental procedure. Further, students must be encouraged to express themselves more fully so that they also develop skill in communicating experimental procedures; analyzing data and drawing conclusions **independently**.* Further suggestions for teaching practical work are contained in SBA Biology modules, 1996, in previous schools' reports as well as in the notes contained in the syllabus.

Part (a) tested the candidates' ability to interpret data. In Part (a) (i) many candidates recognized that the substance in the visking tubing was starch but they provided no evidence for arriving at their conclusion. Far too many candidates do not seem to know that the change of iodine to a blue-black colour is a defining test for starch. Their responses included substances such as water, iodine, alcohol, green

pigment and black pepper. Part (a) (ii) asked candidates to account for the difference between the volume of liquid in the visking tubing before and after the experiment. Few candidates gained the mark here. They were expected to say that water moved into the visking tubing by osmosis. In Part (a) (iii) candidates were required to identify the process by which the **iodine** moved into the visking tubing. Few candidates correctly identified the process as diffusion. The majority of candidates made no distinction between osmosis and diffusion which is an important conceptual distinction in Biology. In Part (a) (iv) candidates were required to draw a conclusion based on the experiment. It is clear from their responses that candidates are still struggling with the term – ‘conclusion’. A conclusion is a statement that is based on the results/data and is related to the aim of the investigation. It should also be noted that the preferred term currently used to describe the cell membrane is **partially permeable membrane** (Institute of Biology on Biological Nomenclature 2000) rather than semi- permeable/selectively permeable membrane. In Part (a) (v) candidates were asked to give a precaution that should have been taken in setting up the investigation. Many candidates were unable to state appropriate precautions such as: *ensure the tubing is not leaking; or carefully wash the outside of the membrane.*

Part (b) of the question asked about changes to the experiment if an amylase enzyme solution were added to the tubing. In Part (b) (i) candidates were required to describe the test suggested to be carried out on the contents of the cylinder after addition of the enzyme, and to state the results expected. This question was fairly well done, but too often the wrong reagents and sequence were used in the test. Part (b) (ii) asked candidates to draw a conclusion based on the expected results in (b) (i). Few candidates seemed to realise that digestion of the starch would produce a reducing sugar and failed to make a clear statement in this regard. Similarly, Part (b) (iii) which asked candidates to explain the results they expected in Part (b) (i), was poorly done. Candidates were expected to explain that amylase converts starch to maltose, which can diffuse through the membrane. In Part (b) (iv) candidates were asked to show how the investigation helped to demonstrate why digestion is necessary. While many candidates were able to demonstrate **why** digestion was necessary, too often digestion was synonymously used with absorption. This also showed quite clearly how imprecisely candidates use biological terms, for which they cannot be rewarded.

Part (c) (i) asked candidates to use the apparatus in Part (a) with different reagents to demonstrate that proteins can be absorbed after digestion. Although a few candidates provided some very good answers, the responses to this question were generally poor. The expected answer should have included details on: *set up of apparatus; a control; enzyme added to protein; food test carried out at intervals to note colour change over time; repeating of experiment.* A good response for this part of the question was:

Protein would be put in the visking tube and NaOH (aq.) and CuSO<sub>4</sub> (aq.) in the graduated cylinder. When the solution diffuses into the tube, purple colour appears, hence protein present but cannot escape visking tube. Add proteases (trypsin and pepsin) into visking tube then test the contents of cylinder for amino acids using a suitable base. Proves that nutrients can only be absorbed after being broken down.

The protein test was generally known, but common misconceptions were that ‘amylase is a reducing sugar’ and that ‘amylase breaks down protein’. In Part (c) (ii) Candidates were asked to state one limitation of the method which they described. Most candidates did not gain the mark here suggesting once more weak Planning and Designing skills. Acceptable responses included *the problem of ensuring that enzyme and protein were thoroughly mixed or the extended period of time for protein digestion to occur.*

Questions in Part (d) were based on the components of a balance diet presented in the form of a pie chart. In Part (d) (i) candidates were asked to suggest why staples were the largest share of the diet. Most candidates obtained this mark by suggesting ideas that included the provision of one of the following - *energy, fibre, bulk or high satiety value.* In Parts (d) (ii) and (iii) respectively, candidates were required to convert the information on the pie chart to percentages and construct a bar chart. These were generally well done, although some candidates did not differentiate between a histogram and a bar chart. A few drew line graphs. In Part (d) (iv) candidates were required to state with a reason, which method (bar graph or pie chart) of displaying food groups would they consider more appropriate. Many candidates had difficulty in answering this question. Either response was acceptable with the appropriate reason. *Bar graphs show the differences more precisely or pie charts are easier to see at a glance/understand.*

### Question 2

This question dealt with aspects of an ecological study. Part (a) required that candidates use the table of data on the number of plants and animals collected in an ecological investigation to answer specific questions. In Part (a) (i) candidates were asked to use the estimated numbers of organisms to identify one species that was likely to be a predator and two that were likely to be herbivores. The majority of the students scored full marks for correctly identifying the appropriate species. Some candidates lost one of the available marks because they identified only one herbivore and not the **two** for which the question asked. In Part (a) (ii) candidates were asked to give a reason for each of the choices made. Very few students scored marks here. The majority of candidates did not use the numbers given in the table, but simply stated what predators and herbivores ate. In addition, many candidates gave a reason for **one** choice only. Candidate responses to this part of the question highlight two examples of the poor test-taking skills that candidates habitually display – **not reading the question carefully and not using the information provided as stimulus material for the question**. Part (a) (iii) was well done by candidates. The majority were able to suggest ways in which a class of students might affect the organisms in a field study and included in their responses ideas such as: *removal/killing organisms; disturbing/disrupting their activities; trampling the grass/ destroying the habitat*.

In Part (b) (i) candidates were asked to use the information provided in the table to explain how the students carrying out the investigation were able to estimate the number of Rabbit Bush in the field. Many candidates did not know how a quadrat is used and were thus unable to provide an appropriate explanation. They generally knew how to calculate the average number of bushes per quadrat but could not explain how to estimate the number of bushes in the field using the data from the quadrat counts. In Part (b) (ii) candidates were expected to explain whether the method used to estimate the plants would also work for estimating animal populations. While the majority of candidates were able to state that the animals moved and plants did not, they often failed to show that their moving would affect the counts and introduce more than acceptable error through animals being counted twice, more than twice or not at all if they are hiding or have moved out of the quadrat. Candidates were generally able to state at least one way in which the students carrying out the investigation might have collected animals which was asked for in Part (b) (iii). Candidates are expected to have experience in using bottles, nets, *jars/traps* for collecting small animals in the field following prescribed guidelines.

In Part (c) candidates were asked to give reasons why the leaf litter habitat was important for the survival of woodlice. The expected responses were to specify that the habitat afforded protection from any two of: *desiccation, predators* and *high temperatures*. Most often candidates cited the leaf litter as a food source, which though accepted was not a completely satisfactory response. Further, many candidates simply said “for protection” which was considered too vague a response. Some candidates seemed to be confused by the terms ‘predator’ and ‘prey’ and suggested that animals in the leaf litter were ‘protected from prey’. Reference is again drawn to the imprecise use of terms and the resulting inaccuracies.

### Question 3

This question dealt with the structure and function of stomata, guard cells and epidermal cells of a variegated leaf. Overall candidate performance was weak. The majority of candidates knew little about the structure and function of guard cells and stomata or the relationship between them. In their answers, many candidates confined the function of the stomata to their role in transpiration and excluded their role in photosynthesis. It is important for students to note that stomata serve gaseous exchange in leaves for **all** processes in which exchange of gases is a feature.

In response to Part (a) far too many candidates claimed that ‘guard cells were for guarding. They were expected to indicate that guard cells *regulate the size of the stoma* while the stoma *allows the exchange of gases*. An acceptable response to Part (a) (iii) was:

Guard cells are sausage-shaped cells, whose inner walls are thicker than their outer walls, the cells bulge when they are turgid. This results in the opening of the stomata, they collapse when flaccid resulting in closing of the stomata. They contain chloroplast and can photosynthesize. In contrast epidermal cells are closely packed rectangular cells with no chloroplast, to allow light to enter the

leaf for photosynthesis. They are covered by a cuticle to prevent excessive water loss and to protect the inner cells from damage and disease.

Common misconceptions were: 'Guard cells are like muscles, seeds, fruits and pollination.'; 'Water was obtained via the stoma'; 'epidermal cells have chloroplasts and guard cells do not'.

In Part (b) candidates were asked to examine a table showing the distribution of stomata in a variegated leaf. In Part (b) (i) they were required to compare the numbers of stomata on the lower and upper surfaces of the leaves and to suggest ONE advantage of the difference in the number of stomata between the surfaces. Many candidates provided calculated differences as their comparison while others ignored this part of the question altogether indicating lack of the basic practical skill of reading data. In offering an explanation for the difference some candidates suggested that the 'stoma admits light so that by being underneath it was protected', and 'water entered the stoma so when rain fell water could not enter'. One of the better responses was:

There were more stomata on the lower surface of the leaf to reduce water loss. With fewer stomata on the exposed upper surface water loss is reduced from that surface.

Candidates performed poorly on Part (b) (ii) in which they were asked to suggest the conclusion that the researcher might draw about the function and importance of stomata based on their distribution in the areas of the lower epidermis given in the table. Candidates were expected to consider the preponderance of stomata in the green areas and make the link with photosynthesis. However, many candidates linked the importance to transpiration and could provide no rationale for this claim. Part (b) (iii) of the question was well done by a majority of candidates. They were required to identify the habitat in which plants with few stomata on both sides of the leaf were found. They were also to explain the benefit of this adaptation. Many candidates identified dry habitats and the fact that fewer stomata on both surfaces reduced water loss. In Part (b) (iv) candidates were required to suggest what difference in their function might allow plants found in dry habitats to thrive despite the fact that their stomata remained closed throughout the day. Candidates were expected to think of the plant taking up carbon dioxide when the stomata were open at night for use in photosynthesis during the day. A good response was worded as follows:

The plants absorb carbon dioxide (which they store) during the night when their stomata are open. This stored carbon dioxide is used during the day in photosynthesis.

#### Question 4

This question examined candidates on their knowledge of the menstrual cycle, development of the zygote and sexually transmitted diseases. Candidate performance on this question was moderate with a mean of **6.4** out of **16** and a mode of **7**.

In Part (a) candidates were asked about the events that take place during the monthly cycle of oestrogen and progesterone. In Part (a) (i) they were required to use arrows on the graph of the menstrual cycle presented to show where certain changes would occur during the monthly cycle. This part of the question was not well done. Candidates were expected to place the arrows to show that pregnancy could occur after Day 14 of the cycle, the breakdown of the lining of the uterus before Day 7 and that the corpus luteum would shrink after Day 25. Candidates did not use the arrows as required by the question. Some used arrows of different lengths and types than given. Some had the arrows overlapping so that the examiner was not sure where they pointed and others used their own versions of the arrows so the examiner could not identify the event to which the candidate referred. In Part (a) (ii) candidates were asked to name the hormone identified as Q on the graph and to give one function. This question was fairly well done. The majority of the candidates identified hormone Q as oestrogen and were able to give one of its function.

In Part (b) candidates were questioned about further changes in the female after fertilization. Part (b) (i) required candidates to add a line to the graph to show changes in the level of progesterone after fertilization. This part of the question was fairly well done. Most candidates recognized that the level of the hormone



would remain high and indicated this in various ways on the graph. Part (b) (ii) which asked candidates what happens to the zygote after fertilization was also fairly well done. Candidates generally indicated that the zygote divided and became implanted in the uterus. However, few candidates specifically stated that fertilization actually occurred in the fallopian tube and after several divisions the developing embryo moved down to the uterus for implantation. A common and serious **misconception** was that the zygote divided by meiosis. In Part (b) (iii) candidates were asked for two ways excluding a pregnancy test that would suggest a woman is pregnant. This was well done with candidates providing a range of responses such as 'menstruation stops', 'nausea and vomiting occurs', and 'increase in size of the abdomen'. There was also the misconception that pregnancy is a 'sickness'.

Part (c) examined candidates on the effects sexually transmitted diseases (STDs) might have on the reproductive process. They were told that STDs can cause scar tissue which block ducts in the male and female reproductive systems and were asked to explain how this blockage can lead to sterility. Most candidates performed well, citing that in the female if the fallopian tube is blocked the egg could not come down to be fertilized, and in the male sperm would not be present in semen. A few candidates erroneously thought that the blockage would prevent the release of the egg or sperm.

Part (d) asked candidates to explain why AIDS, although a sexually transmitted disease did not directly affect the reproductive system. This section was poorly done. Candidates were generally able to state that the AIDS virus destroyed and weakened the immune system. However, they did not explain that while the immune system was the target, the virus actually **gained entry** into the body through the reproductive system. A common misconception was that AIDS is a deficiency disease.

#### Question 5

This question required candidates to interpret data from a table, which gave the effect of temperature and IAA (an auxin) on the germination of passion fruit seeds in six different locations. The table gave the results for seeds treated with IAA and untreated at room temperature and under refrigeration. Candidate performance on this question was fair with a mean of 7 out of 15 and a mode of 7.

In Part (a) (i) candidates were asked to calculate the percentage germination in a specific location at room temperature for seeds treated with IAA. Many candidates were unable to use the data from the table for the calculation. Candidates generally identified the number of seeds that germinated at the location but they could not identify the correct denominator in order to compute the percentage. Candidates clearly need more practice in making simple mathematical calculations that provide a means to manage and interpret biological data. In Part (a) (ii) candidates were required to draw a conclusion about the effect of temperature on the germination of the seeds based on data provided in the table. Most candidates were able to conclude that the rate of germination was higher at room temperature. Too many candidates, however, were unable to distinguish a conclusion from an observation and simply indicated the number of seeds germinated at the temperature. In Part (a) (iii) candidates were to explain how the difference in temperature accounted for the results shown in the table. This section was poorly done. Many candidates simply repeated the answer they had given for Part (a) (ii) rather than give a reason why there was a difference in germination shown by the data in the table. Many candidates merely gave a general answer such as "seeds germinate better at higher temperatures" with no reference to the data nor to the particular question asked. The response to this question was expected to include the idea of *reduced enzyme activity and metabolism as a result of lower temperature*.

In Part (b) candidates were asked about the influence of IAA (auxin) on plants. In part (b)(i) they were asked to explain whether the table showed that IAA affected the results. This section was well done by most candidates. However, too many candidates seem to believe that a difference of 1 is significant when compared to no difference. This error also underscores candidates' unfamiliarity with reading and interpreting data. Candidates did not perform well on Part (b) (ii) which asked about the role of IAA in a plant. They narrowly thought of IAA as important in the response of plants to stimuli such as light or gravity and did not seem to recognize the more general role of IAA as a *growth hormone produced in the tips of shoots and roots and responsible for elongation of the respective organs*.



Part (c) asked questions in which candidates were required to extrapolate about the conditions that may have affected the growth of the seedlings suggested by the results given in the table. In Part (c) (i) candidates were required to identify the location in which the seedlings grew fastest. Most candidates were able to correctly identify the location as required. In attempting to identify two conditions needed for growth of seeds which Part (c) (ii) of the question required, a surprisingly large proportion of candidates gave “light” as a condition and explained that it was needed for photosynthesis. This is a familiar misconception of candidates and there is need for teachers to re-emphasise that the conditions which seeds usually require for germination are: *oxygen, water and a suitable temperature*. In addition, candidates seemed unaware of the reasons why these conditions are required for seeds to germinate. For example, many candidates who correctly identified water failed to give its significance in *activating enzymes and transporting dissolved and/or soluble nutrients*. Many candidates who identified oxygen did not indicate its *role in respiration so as to provide energy for growth and other metabolic activities*. Part (c) (iii) asked candidates to suggest how the way in which humans took care of their embryo before birth was **different** from that in the plant. This part was only fairly well done. Candidates who responded reasonably well to the question generally referred only to the provision of nutrients. Very few referred to *gaseous exchange, excretion or protection from bacteria*. Many of the candidates who referred to how the nutritional needs of the human embryo were met did so without reference to the role of the placenta or umbilical cord.

### PAPER 03 – Extended Essay

Candidates’ performance on this paper was slightly better than that in June 2003 with the mean at **40%** compared with the previous mean of **39%**. Nevertheless some observations about candidate performance remain consistent. Candidates demonstrated a continuing ability to write at length about biological events, principles and concepts. They also continued to display the tendency to provide all the information they knew on a topic rather than select what was pertinent to answering the question. There was also evidence that in spite of time allotted for reading the paper, candidates missed key words in the questions and provided answers which were off the point. It is thus reiterated that candidates should be advised that the reading time should be used to read through each question carefully, highlighting key words on which the questions hinge, so that they would be less likely to misread and misinterpret questions. **The reading time should also be used to plan their responses so that they are more likely to stick to the relevant topics.** It is clear that much time is spent on teaching and learning the content of the syllabus. However, more attention needs to be paid to important examination techniques which will allow candidates to make the best use of what they know.

#### Question 1

This question tested candidates’ knowledge of fruit and seed dispersal and ways in which plants are adapted for successfully inhabiting their environment. The question also examined candidates’ understanding of the role of ‘nature’ in controlling plant and animal populations. Candidate performance on this question was unsatisfactory.

In Part (a) candidates were required to describe two different methods of seed or fruit dispersal including relevant adaptations and examples. This part was badly done. This was rather disappointing given the basic biological knowledge involved. The most frequent errors made by candidates were: describing pollination rather than dispersal; describing flower, seeds and seedling as one and the same; mistaking egestion for excretion. Many candidates stated how the seeds / fruits were moved from one point to another without stating the relevant adaptations.

Part (b) of the question asked about alternatives for plants without special dispersal mechanism and required candidates to deduce possible plant adaptations for a given scenario. Both sections of Part (b) were not at all well done. In Part (b) (i) candidates were required to suggest why although many seeds from plants with no special dispersal mechanism germinate, few reach maturity. Candidate responses were expected to include ideas such as: *overcrowding; competition for nutrients/ light/ water; some were better adapted than others – more viable; more efficient; some grew faster* for those that grew to maturity compared to those that *were less well adapted and died*. Some candidates who included the ideas of overcrowding and competition for food were not specific and thus failed to gain many of the available

marks. An example of such responses was simply stated as: “over-crowding and competition for resources” – omitting what the resources were. Part (b) (ii) described the behaviour of the fruit, seed and seedlings of a type of forest tree and asked candidates to suggest the characteristics that these parts of the tree might have. This part of the question was not well done. Many candidates re-wrote the information provided in the stimulus material or gave a list of the conditions required for germination, ignoring the stimulus material. Candidates were expected to indicate that *the fruit/seed would be large/heavy; have tough outer coverings – not easily rot; store large amounts of food material. They were also expected to consider that the seedlings would grow faster and not need much light.*

Part (c) of the question, which examined candidates’ understanding of the natural ways by which the growth of human populations might be controlled, was not done well. Candidates were expected to refer to such conditions as: *adverse climatic conditions/ weather; disease; scarcity of food.* They were then required to explain how these factors affect human populations and why human populations may be less vulnerable to some of their adverse effects. The most frequent misconception shown by candidates was in the meaning of the term ‘nature’. In Biology ‘nature’ refers to natural conditions or conditions not caused by human interference. In a Biology examination the precise biological meaning of a term is expected and this may be different from the use of the same word by the layman.

## Question 2

This question was more popular among candidates than its counterpart in Section A. It tested candidates’ knowledge of heterotrophic and autotrophic nutrition, adaptations of heterotrophs and some aspects of ecology. Candidates performed poorly on this question and their performance was quite similar to their performance on Question 1. Candidate performance was all the more disappointing given the fundamental nature of the topics in the subject. The mean for this question was consequently low and candidates failed to score across the range of marks.

In Part (a) (i) candidates were asked to distinguish between heterotrophic and autotrophic nutrition. Candidates were unable to make a satisfactory distinction. Their responses were expected to make distinctions between autotrophic and heterotrophic in terms of *the use of simple substances compared with complex ones; inorganic versus organic; making of own food compared with depending on other organisms*, respectively. Candidates generally need to develop their comparison skills. When making comparisons candidates need to draw attention to the distinctions or similarities point by point and not simply provide two consecutive descriptions.

Part (a) (ii) required candidates to identify three types of heterotrophic organisms found in food webs, giving examples, and to explain why different types of nutrition are found in food webs. This part of the question was also not very well done. The expected response was: *carnivore, herbivore and omnivore* with appropriate examples. Most candidates failed to consider these nutrition types and cited ‘saprophytes’, ‘parasites’, which were rewarded, and others such as ‘predator-prey’ and ‘symbiotic’, which were not rewarded. Few candidates were able to provide an adequate explanation for different types of nutrition in food webs and seemed unfamiliar with the following ideas: *in food webs there is a dependence on plants as the energy source; there is interdependence among organisms in the food chains; the variety of types of nutrition reduce competition for resources; there is a concept/existence of the ‘niche’ in food webs.*

Part (b) required candidates to explain the adaptations heterotrophs possessed to obtain food, extract nutrients and absorb the extracted nutrients. Although candidates were guided to frame their responses using humans as an example of a heterotrophic organism, they did not perform very well on this part of the question. Candidates spent an inordinate amount of time addressing the process of digestion rather than singling out adaptations for the functions asked and describing how these features are designed to efficiently carry out their functions. For example, candidates were expected to refer to: *hands, mouth, teeth, to catch/grind food; alimentary canal with appropriate muscles to move food; enzymes to break large molecules into smaller ones; increased surface area in absorptive parts of the alimentary canal to facilitate the uptake of digested food.*

Part (c) asked candidates to suggest why food webs can be considered large recycling systems and farms disrupted food webs. Performance on this part of the question was poor. Candidates needed to show how the cycling of materials occurred in food webs. They were expected to capture the following in their responses: *plants absorb simple substances from the air and soil, materials pass from one trophic level to the next, waste from plants and animals are broken down by micro-organisms, products of the breakdown process are reused by plants.* With respect to the view that farms were disrupted food webs. Candidates were expected to show how the farm, although generally functioning like a food web, had a number of key differences primarily related to the artificial nature of farms: *plants removed as crops and not recycled; farm animals and pests are killed; artificial chemicals are added to the soil.*

### Question 3

In Section B, question 3 was the preferred choice of the candidates. It examined their knowledge of the relationship between photosynthesis and respiration, the impact of humans on the environment and conservation methods. Candidate performance was fair as shown by a mean of **9** and a mode of **10**. In addition, candidates were able to score across the range.

In Part (a) candidates were asked to explain the relationship between photosynthesis and respiration outlining the processes involved. Most students were able to give information on photosynthesis although many could not give a balanced chemical equation for the process and felt that it occurred in either of the 'chlorophyll', the 'palisade tissue' or simply in the 'leaf'. Candidates were expected to cite the chloroplast. The site where respiration occurred was also not well known. Few candidates identified the mitochondrion as the site of respiration and many stated that the process just took place in the cells. Candidates generally did not seem to know about the photolysis of water and reduction of carbon dioxide to carbohydrate in the photosynthetic process even though this is a clear syllabus objective. The text of a good response was:

The products of photosynthesis are glucose and oxygen. These are the reactants for respiration and the products of respiration, carbon dioxide and water are the reactants of photosynthesis. Photosynthesis takes place in the chloroplasts of cells and involves the splitting of water molecules into hydrogen and oxygen atoms using light energy from the sun. The hydrogen atoms react with carbon dioxide to form glucose which is converted to other carbohydrates. The process can be represented by ... (correct equation given).

Respiration is the process in which living organisms release energy from glucose. The reaction takes place within the mitochondria of cells and oxygen is usually used up in the process. It can be represented by the following equation: ... (correct equation given).

Several **misconceptions** were noted in the responses to this part of the question. These included: respiration is the same as transpiration; both processes give off energy; and perhaps the most common misconception - photosynthesis occurs in the day only, while respiration occurs in the night only.

In Part (b) (i) candidates were asked about the effects of removing vegetation on a large scale from a forested area and replacing it with a national park with ornamentals as a tourist attraction. Most candidates seemed well aware of the effects of removing large tracts of vegetation from a forested area and gained most of the available marks. A few candidates seemed to think that 'ornamental flowers' meant artificial flowers. Some were also confused by the concept of 'on a large scale'. Such candidates wrote extensively on 'global warming', 'increase in carbon dioxide concentration', and 'depleted oxygen levels'. A national park in their minds contained large animals that could be dangerous. Candidates were expected to include in their responses: *destruction of flora /fauna; soil erosion; introduction of pests and diseases among other ideas.* A good response follows:

Large-scale removal of trees will result in soil erosion. Leaves act to buffer the impact of rain drops and allow percolation of water into the soil. Roots also bind the soil particles together. The removal of trees, therefore, allows water and wind erosion to occur. In addition, there is the loss of fauna associated with the habitats created by the presence of trees. These animals will either die or be forced to move to other forested areas since their habitats and food supply will be destroyed.

Part (b) (ii) asked candidates to create rules relevant to conservation for visitors to the park and explain the importance of each rule to conservation. This part of the question was quite well done. Candidates' responses included: *proper garbage disposal; number of vehicles entering the park; no removal of plants; no walking on lawns; no picking of flowers* among other ideas. Some skilfully linked an economic rule to a 'conservation explanation'. However, some candidates ignored the part of the question that asked for an explanation of the importance to conservation and only stated the rules. This also shows how candidates unwittingly and /or unnecessarily lose marks.

#### Question 4

This question examined candidates understanding of the importance of blood to the body, blood constituents, the importance of blood groups, how blood groups might be inherited and the function of blood components. Of the pair of question in Section B, question 4 was less popular but was generally well done. The mean for the question was **10.58** and a mode of **14**, one of the highest scoring essay questions in the history of the examination. Several candidates scored full marks.

In Part (a)(i) candidates were asked about the effects of prolonged loss of blood. Most candidates were able to suggest several effects. However, candidates generally failed to mention those effects related to the *loss of water* and resulting *lowering of metabolism*. Generally, unsatisfactory responses were made to Part (a) (ii) which asked why it was necessary to place the child, who was involved in an accident, on a 'drip'. Candidates simply perceived the 'drip' as 'life saving' with the function of, replacing blood which was lost or making blood. Candidates were expected to include in their responses concepts such as *re-hydration of the body or increase energy level*.

Part (b) (i) of the question required candidates to use appropriate diagrams to show how the child in question could derive a blood type that is different from both parents. While most candidates were able to correctly represent the inheritance of the blood type, in several instances their diagrams and symbols did not adhere to genetic conventions. Adherence to the conventions for inheritance should be encouraged. One misconception was that blood-type inheritance is sex-linked. Part (b) (ii) asked for two reasons why people may be reluctant to donate blood. This part of the question was reasonably well done. The most common response was: 'fear of contracting or passing on diseases'. Common misconceptions were that deficiency diseases as well as hereditary diseases can be passed on through blood transfusion.

Part (c) was generally well done by candidates. They were required to explain the function of four essential components of artificial blood. A number of candidates did not identify the blood component for which they were highlighting the function. This shows inadequacy in test-taking skills. The better responses always made a clear relationship between the blood component and the function and thus accessed the marks allotted more readily.

#### Question 5

This question was the less popular of the pair of questions in Section C. It tested the candidates' knowledge of cloning, meiosis, sex determination and the application of genetic engineering. Candidate performance was only fair although candidates were able to perform across the range of marks for the question. The mean score was **6.44** while the mode was **7**.

In Part (a) (i) candidates were asked to explain why all members of a clone have the same genetic makeup. This question was fairly well done, but many candidates did not include in their explanation that *chromosomes replicate prior to mitosis, so that the daughter cells produced contain the same DNA or genotype as the parent cell*. Several candidates were unable to distinguish between mitosis, meiosis and binary fission. In Part (a) (ii) candidates were required to explain the terms –'separation of homologous chromosomes' and 'separation of chromatids' and further, to indicate why these events are important. This question was not well done. Many candidates described the stages of meiosis, but did not mention the importance of the separation of homologous chromosomes and chromatids. Candidates' explanations were expected to include such concepts as: *homologous chromosomes refer to the pairs of chromosomes; one member of this pair is derived from each parent; crossing over occurs prior to the separation of*

*homologous chromosome; separation of homologous chromosomes produces two haploid cell; haploid cells are genetically variable; chromatids separate in the second stage of meiosis to produce four haploid cells.'*

Part (b) of this question required candidates to explain why it was unreasonable for men to blame their partners for having too many female children. This part of the question was only fairly well done. Candidates often showed some misconception about the processes involved in sex determination. Some candidates even had the erroneous impression that male gametes were dominant to female gametes. Candidates were expected to describe the process by which the sex of an offspring is determined. Their responses were expected to demonstrate an understanding that: *sex is determined by the sex chromosomes; the female has two X chromosomes (XX) and the male has an X and a Y chromosome (XY); the female can contribute **only** an X chromosome to her offspring; the male can contribute **either** an X or a Y chromosome; fertilization is random; there is an equal chance of a couple producing a male or female offspring; neither parent directly controls the genetic process.*

Part (c) of the question examined candidates on their knowledge of genetic engineering and its potential. In Part (c) (i) candidates were expected to describe the advantages of removing a defective gene from a zygote or gamete and replacing it with a normal gene, instead of trying to develop a better treatment for the genetic disease. Candidates seemed to know very little about genetic engineering and some thought that AIDS and other STD's were genetic diseases. For some candidates, points were not well developed. A good answer was expected to include the following: *genetic diseases cannot be cured; treating the patient is not permanent; the altered genotype can be passed on to new cells in the organism/ passed on from generation to generation.* In Part (c) (ii) candidates were asked to suggest one advantage and one disadvantage of being able to select certain preferred characteristics and have the appropriate genes inserted into their embryonic offspring. While candidates made some reasonable suggestions, their responses were not well developed. They were expected to cite advantages such as: producing more intelligent, healthier offspring; society may benefit from higher productivity. Disadvantages were expected to include: *expensive only rich could afford the procedure; unethical; religious objections.*

#### Question 6

This question was by far the more popular of the pair of questions in Section C. It tested the candidates' knowledge of deficiency diseases and physiological disorders - hypertension and diabetes. Candidate generally performed well on this question and scored across the range of marks. The question had a mean score of **9.28** and a mode of **10**.

In Part (a) (i) candidates were expected to state the meaning of the term deficiency disease. This part of the question was well done, but sometimes candidates failed to give an appropriate example, such as scurvy, caused by a lack of vitamin C or anaemia, caused by lack of iron. Part (a) (ii) required candidates to explain why some nutritional disorders cannot be called deficiency diseases. Although this question was fairly well done, the responses were not well developed. For instance, some candidates mentioned with reference to a physiological disease the 'inability of an organ to function', but gave no example. A good response contained the following:

Anorexia / bulimia are eating disorders that may lead to deficiency disease, but is not caused by one. Diabetes is a physiological disease, which is related to nutrition but it is not caused by a deficiency in the diet. ...

Far too many candidates believed that these diseases are inherited diseases.

Part (b) of this question asked candidates to compare the causes, treatment and control of diabetes and hypertension. Few candidates made complete comparisons between the two diseases. They tended to describe one disease followed by the other. Most candidates equated treatment with control. Candidates should be informed that treatment deals with supplying care or medication to alleviate an illness and control deals with measures which are taken to prevent an illness or reduce the severity of an illness/condition. Many candidates described the condition and its symptoms rather than distinguishing between their causes, treatment and control as the question asked.

In Part (c) (i) candidates were required to comment on the long-term effect that the high incidence of diabetes and hypertension might have on the development of some Caribbean countries. It was gratifying to note how well students performed on this part of the question. In Part (c) (ii) candidates were to discuss how the change to a more modern life style may be contributing to the increasing incidence of these two diseases in the Caribbean. Some students misinterpreted the question and their responses were related to 'what would contribute to the increasing incidence of these two diseases'. The following was a good response:

Popularisation (sic) of fast foods has led to the consumption of foods with a high fat and sugar content. People drive in cars and have appliances to make housework easier, hence they seldom exercise. People experience a great deal of stress on the road and on the job. These factors contribute to an increase in the incidence of diabetes and hypertension.

A significant number of candidates scored full marks on this question.

## **PAPER 4 – School Based Assessment**

### **GENERAL COMMENTS**

Performance in the School-Based Assessment (SBA) was, for the most part, commendable; the work produced by the candidates was fairly good and most teacher assessments were satisfactory, the standard of marking being close to that expected by CXC. There was good coverage of the required syllabus topics and the number of activities included in the books was generally adequate. There is continuing evidence that Observation Recording and Reporting (ORR) was the best-developed skill while Analysis and Interpretation (AI) and Planning and Designing (PD) are still problematic. This observation highlights the need for a more experimental approach to the SBA. The suggestion is that more practical exercises should be attempted with an approach that facilitates the development of critical experimental skills which is a major goal of the SBA.

A review of previous reports will provide further suggestions for developing practical skills. Further suggestions have been made in this report and each teacher has been alerted to the specific strengths and weaknesses displayed by their candidates in the Moderation Feedback Form sent to schools from CXC headquarters. Teachers should also review the 2002 School's report to obtain an overview of the moderation processes and the expectations of the moderators.

The following are recurring problems:

- Many teachers show a tendency to mark weaker candidates less stringently than they mark more competent students.
- At some centres students are not being assessed the required number of times for each skill. Teachers should try to plan the terms work so that this does not happen in the future as it puts their students at a serious disadvantage.
- Teachers are reminded that body fluids such as saliva, blood and urine should not be used for practical work as these fluids can be sources of infection. Teachers who ask students to use body fluids leave themselves open to legal action should a student claim to have become infected as a result of lab work.

Please note that all lab books are expected to have a complete *Table of Contents, numbered pages* and a clear indication of *which labs have been marked for SBA*. In far too many cases moderators were unable to locate the source of the marks included on the record sheets. This means that moderators have to select the labs to be remarked as part of the moderation process. It should be clear to teachers that this often puts their students at a severe disadvantage.



## SPECIFIC COMMENTS ON THE ASSESSMENT OF SKILLS

### **Observation / Recording / Reporting (ORR)**

These skills appear to have been mastered at most centres. Tables and graphs were well done, methods were clearly described and observations sufficiently detailed. It should be noted that constructing graphs is a recording skill and is correctly assessed for ORR. However, interpreting graphical data is not a recording skill and must be assessed for AI.

*Fieldwork appears to be on the decline. At some centres little or none is being done. Those centres that attempted fieldwork frequently neglected either the quantitative or qualitative investigations. Both aspects of fieldwork are expected. Investigations need not be elaborate but students should be given the opportunity to learn the required skills.*

### **Drawing (Dr)**

The standard of drawings appears to have deteriorated at some centres and in some cases only the minimum number of drawings were found in the lab books. Copied text book drawings should not be assessed for drawing skills. Students should make drawings of specimens, seeds etc. Examination of lab books did not always support the excessively high marks shown on the record sheets.

The following should be noted: **All lab books are expected to contain drawings of at least flowers, fruits, a seed, storage organs and bones.** Although it is very useful for students to observe specimens under the microscope and attempt to record what they observed, at this level these drawings should NOT be used for SBA. Similarly, dissections may help students to understand structures such as the digestive system but they are too complex to be drawn accurately at this level. These difficult drawings do not provide a fair test of ability at this level.

### **Analysis and Interpretation (AI)**

This skill is still presenting problems for the majority of candidates. Discussions are expected to provide some background information or the general principles on which an investigation is based. Results should then be explained. When a control is used it provides a point of comparison for the experimental set up in which a particular variable has been omitted. This comparison should be included in the discussion as it is the key to drawing the conclusion. Conclusions should relate directly to the aim of the investigation. Students should also be reminded to discuss at least one limitation of the investigation. It is important for them to recognize that the conditions present in a school laboratory are rarely ideal.

Many teachers continue to use questions to stimulate discussion. This device is good for helping students to develop their AI skills. However, they should not be used excessively, nor should they be the only means of assessment of the AI skill. These questions must guide students to provide the required background information, give explanations for the results, draw conclusions and show an awareness of possible limitations. The information provided in this way should then be written up as a paragraph of continuous prose as is normally done for the discussion/ conclusion. In many cases, candidates seem to have learnt a formula for writing up the discussion but showed no real understanding of how to interpret their own results. As a learning strategy teachers may ask their students to orally explain the results to obtain a clearer view of their understanding and to help them develop their analytical skills.

It should be noted that food tests, on their own, are not appropriate for assessing AI. Simple investigations can be designed in which food tests are used. For example, students can be given unknown mixtures and asked to find out which food would be most suitable for an infant. Food tests can be used also to determine the presence of a particular food before and after digestion by an enzyme. These types of exercises will allow students to develop the necessary skills. Knowledge of the food tests and the nutritional requirements can then provide the background information on which they will base their conclusions.

Moderators were also concerned at the narrow range of investigations assessed for AI. With the exception of patterns of growth in seedlings, very few candidates seemed to have been exposed to investigations other than experiments. Investigations that require collecting observations over a period of time are ideal for discussing limitations as they lack controls and so many variables may change. These limitations can then be used as the basis for planning and design exercises. For example, students can be asked to

find out which of the flowers in a garden butterflies prefer or what types of moths a house lizard eats by completing a table of observations over a period of days or weeks. They can then use the observations to develop a hypothesis and design an investigation that would test it.

### **Planning and Designing (PD)**

Considerable improvements have been noted in this area. Some teachers have been very successful in getting their students to understand the general principles involved. There were also a number of very interesting observations provided for students to deal with. However, teachers must be careful that students are not only taught the format for writing up the exercise as happened in some cases. There were a number of **inappropriate observations** that follow the correct format but do not give students any real designing to do. The following example makes the point clear:

Observation: Bread rises when yeast is used.

Hypothesis: Yeast causes bread to rise.

Aim: To find out if yeast causes bread to rise.

Method: Mix some yeast with flour and see if it rises and compare to flour without yeast.

Expected Observation: Flour mixed with yeast will rise.

**To provide students with a reasonable challenge a suitable variation could be used.** For example, it may be observed that bread rises faster on hot days. Students can then be asked to develop a hypothesis and design an experiment to test it. This would allow a teacher to assess their students' ability to plan and design an experiment more fairly.

The following requirements are drawn to the attention of those teachers who are unfamiliar with them:

- Planning and designing activities should be based on an observation from which students can develop a hypothesis and then plan or design a suitable method for testing the hypothesis.
- A hypothesis that is provided by the teacher should not be awarded marks.
- The observation and the hypothesis, whatever their source, must both be included in the write up of the design, for purposes of assessment. Moderation of a plan is not possible without a hypothesis as the plan only makes sense when it can be matched to the hypothesis.
- Acceptable designs should focus on a single variable. For example, if salted fish is found to have a particular effect on boiled bananas it is reasonable to suggest that the salt is responsible for the observation. The hypothesis should refer to the salt as the variable affecting browning and not the fish.

It is clear that in many cases the only exercises attempted for PD are the minimum number required by the CXC syllabus. This is a disadvantage to the student's, as they cannot be expected to perform well in this skill without adequate practice. It should be remembered that Question 1 on Paper 2 also demands familiarity with this skill. It is suggested that, at the very least, students be encouraged to discuss plans for a given hypotheses from the time they begin preparing for the CXC syllabus.

Teachers should remind their students that practical activities written in the past tense and those that are commonly found in text books will not be accepted for assessing PD.

### **Manipulation and Measurement (MM)**

As in previous years, the marks for this skill were good. However, as was stated in the previous report, in many cases there was reason to suspect that these marks were not the result of rigorous marking. If, as happened in more than one case, virtually all students in a class gain full marks, perhaps the task is not demanding enough or the criteria not detailed enough to allow the necessary discrimination between different levels of performance. Teachers are reminded that marks for MM must be written down in the lab books, next to the labs for which they were awarded, and mark schemes and detailed criteria should be submitted as done for all other skills.



**CARIBBEAN EXAMINATIONS COUNCIL**

**REPORT ON CANDIDATES' WORK IN THE  
CARIBBEAN SECONDARY EDUCATION CERTIFICATE**

**JANUARY 2005**

**BIOLOGY**

**Copyright © 2005 Caribbean Examinations Council  
St Michael, Barbados  
All rights reserved**

**BIOLOGY**  
**SECONDARY EDUCATION CERTIFICATE**

**JANUARY 2005**

**GENERAL COMMENTS**

The January 2005 examination in Biology consisted of four papers:

Paper 01 – Multiple Choice

Paper 02 – Structured questions

Paper 03 – Extended essays

Paper 04 – Alternative to the School Based Assessment.

There was a decline in the performance of candidates in this examination compared with January 2004. The greatest decline was seen in Paper 04/2, the Alternate to the School Based Assessment. Performance of candidates in Paper 01, the Multiple Choice paper, remained satisfactory and stable, while there was a marginal decline in Papers 02 and 03, the Structured and Essay Papers respectively. There is need for improvement in the preparation for the examinations. Particular attention should be paid to the following comments in preparing candidates for the examination, if the desired improvement is to be realized:

- Candidates must improve their test-taking skills. This involves practice in reading questions carefully and planning responses so that answers are organized in a logical and cohesive manner.
- Candidates wasted time providing irrelevant information in the essays. They should focus on key words such as 'describe' and 'explain' when reading questions to ensure that their responses are relevant. In many cases responses were too brief and did not satisfy the requirements of the questions.
- Very often responses were written too simply, without using appropriate biological terms. It was evident that candidates were not comfortable using scientific language in their responses. Teachers must therefore emphasize appropriate biological terminology throughout the course.
- More attention should be paid to the stimulus material provided in the question, particularly in Paper 02. This usually guides students to the correct responses. Too often candidates responded by providing information on the topic which did not relate specifically to the question.

- More emphasis should be placed on practical skills. Many candidates seemed to be unfamiliar with the materials and equipment mentioned in the examination, especially in Paper 04/2. They did not fully understand the precautions and limitations of an experiment, and were unable to state the aim of an experiment or formulate a valid hypothesis.

## DETAILED COMMENTS

### PAPER 02 – STRUCTURED QUESTIONS

Paper 02 consisted of five short-answer structured questions. The first was a data analysis question worth 30 marks. The paper tested all skill areas in the Biology syllabus. Performance of the candidates was satisfactory. The overall mean was 34.42 or 38.29 percent.

#### Question 1

This question tested the effect of temperature on enzyme action. Stimulus material was provided in the form of a series of experiments showing the reactions of a human digestive enzyme at various temperatures. Candidates were expected to make observations, interpret data, draw conclusions and apply their practical skills to plan an experiment. They were also asked to describe the procedure for a food test. The mean for this question was 11 and the highest score was 24 out of 30.

In Part (a) candidates were required to record observations after starch was mixed with an enzyme and the product of the reaction tested with iodine. Performance was unsatisfactory. Many candidates were unable to complete the key based on the data illustrated in the Figure. The blackened circle represented blue-black/purple/dark blue while the non-blackened circles represented brown/yellow.

In Part (b) (i) performance was satisfactory. Candidates were expected to explain why the colours of the drops in rows A and E remained the same. Although most candidates knew that enzymes were denatured at high temperatures only a few realised that enzymes were inactivated at very low temperatures. For Part (b) (ii) candidates were expected to identify maltose as the product of starch digestion. The performance was generally good, although weaker candidates stated 'glucose'. In Part (b) (iii) candidates were expected to describe the test for reducing sugar but, in many cases, they described the test for

starch. Where an attempt was made to describe the reducing sugar test the need for heat was often omitted.

Performance in Part (c) (i) was satisfactory although a few candidates plotted a bar chart instead of a graph. Part (c) (ii) was well done. Most candidates correctly identified the temperature at which the reaction took place most rapidly as 30°C. For Part (c) (iii) most candidates correctly stated that there would be an increase in enzymatic activity as temperature increased from 0°C in Tube A and that a change in tube E would have no effect since the enzyme was already denatured.

In Part (d) (i) candidates were asked to describe the method used to set up the investigation. Many failed to provide the correct sequence of steps for the method and were unable to state appropriate precautions. Examiners expected precautions such as use the same size drops; keep the temperatures of the water baths constant; leave the mixture to stand for the same length of time; stir before moving drops. Part (d) (ii) was well done as candidates were able to explain that it was important to stir the mixture so that the contents would be thoroughly mixed. Mixing would ensure even distribution of heat and the reaction of all starch with the enzyme.

The Performance in Part (e) (i) was generally good. Most candidates were familiar with the procedure for preparing the cotyledons for testing. In Part (e) (ii) they were asked to explain what happens to the starch stored in cotyledons when a seed germinates. Few candidates were able to explain that the starch is converted to glucose in the presence of enzymes and then translocated to the growing points of the seedling when the seed germinates. Topics on germination should not be confined to the conditions necessary for it to take place but should also include reactions taking place during the process.

Part (f) had as its stimulus, an illustration of a box of germinating seedlings. Most were bending in one direction. Candidates were asked to explain the appearance of the seedlings. Performance was fair but some candidates had difficulty explaining the representation as growth in the direction of unilateral light and, instead, explained it as 'wilting' due to lack of water. Candidates who were unable to correctly explain the appearance in Part (f) (i) found it difficult to set up an appropriate investigation to show that their explanation was correct using a shoebox with a hole. Many of them suggested placing seeds in the box for germination.

## Question 2

Breathing and respiration were the topics targeted in this question. Candidate performance was moderate with a mean of six and the highest score 15 out of 17. In Part (a) (i), candidates were required to identify the parts of the chest cavity involved in breathing, while in Part (a) (ii) and (iii) they were to indicate the positions of the diaphragm and rib cage while breathing. Part (a) was generally well done as most candidates were able to identify the parts and gained at least three of the six marks.

In Part (b) (i) most candidates indicated the correct location of the alveoli. However, in Part (b) (ii) the two major blood vessels branching to form capillaries in the alveoli were often given only as arteries and veins and not more specifically as pulmonary arteries and pulmonary veins. Students should be more precise in their language and be able to use biological terms with facility. In Part (b) (iii), they were required to explain how oxygen in the lungs moves to the rest of the body and into cells where it is needed. Few candidates gained full marks. Most could not provide an explanation using scientific terms and did not use key words such as 'haemoglobin' and 'diffusion'. However, among the good responses was 'when deoxygenated blood enters the lung from the right side of the heart CO<sub>2</sub> is diffused outward, oxygen is diffused in the blood returns to the heart and pumped around the body, O<sub>2</sub> is transported via oxyhaemoglobin in red blood cells'.

In Part (c), most candidates correctly responded to the importance of breathing. However, one noted misconception was that breathing is the same as respiration. The responses to the importance of respiration were generally poor. It was evident that students still have difficulty understanding that respiration takes place at the cellular level. One good response was: 'Respiration is the process where food is broken down by oxygen to carbon dioxide, water and energy. Energy is used for metabolic processes'. In Part (c) (iii) candidates were asked to suggest why plants do not need to breathe, although respiration is important to them. Few candidates gained marks in this section since most wrote about photosynthesis rather than respiration.

## Question 3

Question 3 dealt with photosynthesis and respiration and the changes in environmental carbon dioxide concentrations as these processes take place during the day. Performance was satisfactory with a mean of 7 and the highest score: 16 out of 16.

In Part (a), candidates were required to study a graph of the carbon dioxide concentration in the air of a rain forest and describe the changes during the period. Some described the lowering of the CO<sub>2</sub> concentration between 4.00 a.m. and noon but failed to mention the subsequent steady increase, followed by a period of levelling off. The better candidates gained all the available marks by using the available data to state more precisely the amount by which the levels rose and fell. For example, the initial decline was from 5.5 percent to 3 percent. In some cases, candidates gave explanations for the shape of the graph and did not describe the changes in carbon dioxide concentration. They failed to gain the available marks.

Part (b) (i) was well done. Most candidates stated that respiration and photosynthesis would affect the amount of carbon dioxide in the atmosphere. In Part (b) (ii), candidates were asked to explain the changes taking place in the carbon dioxide concentration over the forest between 4.00 a.m. and 4.00 p.m. Although the majority of the candidates named respiration and photosynthesis in Part (b) (i), they were unable to explain the relationship between those processes and CO<sub>2</sub> concentration over the forest. Many focused on photosynthesis indicating that CO<sub>2</sub> concentration would decrease as photosynthesis increased from 4.00 a.m. to noon and failed to mention that respiration would also be taking place but giving off CO<sub>2</sub> at a much lower rate than it is being used in photosynthesis. After noon more CO<sub>2</sub> was released into the atmosphere as the rate of photosynthesis steadily decreased.

For Part (c) (i), candidates were asked to state which environmental factor was mainly responsible for the changes observed over the period 4 a.m. to 4 p.m. The majority of the candidates correctly identified the factor as sunlight. In a few cases, responses indicated that candidates did not understand the term environmental factor.

Performance on Part (c) (ii) was similar to Part (b) (ii) where candidates only provided an explanation for the decline during the first part of the day from 4.00 a.m. to noon without any mention of the remainder of the data provided.

Part (d) required candidates to give three biological reasons for the importance of forests. This was generally well done. Many candidates scored full marks. An example of a good response was:

'Forests recycle the air and help to reduce pollution. They produce oxygen and reabsorb carbon dioxide from the air. They provide a habitat for many organisms. They provide a food source for organisms and help to prevent erosion and hold soil together.'

#### Question 4

Several objectives were examined in this question: the structure and function of the plant cell, distinguishing it from an animal cell, and the basic principles of genetics and osmosis. Performance was satisfactory with a mean of 6 and the highest score: 13 out of 13.

In Part (a), candidates were required to identify the structures of the plant cell. The majority of the candidates were able to identify at least 2 of the 4 structures. A common error was that the chloroplast was often identified as the mitochondrion. In addition, a few candidates incorrectly labelled the cell wall as the cell membrane.

In Part (b) candidates understood the functions of the chloroplast while the common response for the vacuole was storage; very few mentioned turgidity and no one wrote transport.

In Part (c), candidates were asked to state two ways that the plant cell is different from a human white blood cell. Almost every candidate was able to score at least 1 mark, correctly noting the presence of the cell wall, chloroplast or large central vacuole which does not occur in the blood cell.

In Part (d), the number of chromosomes of the plant cell was given as 12 and candidates were required to determine the number of chromosomes that would be present in the petals and pollen grains of its flowers. A few candidates gave unexpected responses such as thousands and thousands in the petal. A common response, however was 46 in the petal and 23 in the pollen grain. This was probably due to simple recall of irrelevant information without an understanding of the basic concepts in genetics and cell biology. The petal has somatic/vegetative cells with the diploid chromosome number 12, while the pollen grain is a reproductive cell which has the haploid number of chromosomes 6, resulting from meiosis.

In Part (e) candidates were asked to describe what would happen if the plant cell were placed in a 50 percent sugar solution. It is evident that the concept of osmosis is not well understood since this question gave a large number of candidates difficulty. Many felt that since the sugar solution was more concentrated it would diffuse into the cell causing it to swell. However, those who understood the principle of osmosis with regards to plant cells did justice to the question. A notable response was

‘Water will move out of the cell sap into the more concentrated solution making the solution outside dilute. The process of osmosis will occur. As water leaves the plant cell it become(s) more flaccid and if the cell membrane tears away from the cell wall, the cell may be plasmolysed’.

### Question 5

The topics dealt with in this question included genetics; plant breeding (artificial selection) and pollination. Performance was below the standard with a mean of 4 and the highest score: 13 out of 14.

In Part (a) (i) candidates were asked the meaning of the term homozygous. Responses were generally poor. Some candidates believed that similar alleles were found in the same chromosome and also confused homologous with homozygous. Part (a) (ii) was poorly done. A common problem was to show the parents’ genotypes with different letters, for example LS, this response indicates that candidates failed to recognize that the question stated that the parents were true breeding (homozygous), or based on the responses to Part (a) (i) many did not know the meaning of the term homozygous; consequently, their responses were incorrect. In the question the small flowers were dominant, but a few candidates used the recessive alleles for the small flowers. It is necessary for students to follow and apply the international conventions in genetics where the upper and lower case of one letter represent dominant and recessive alleles of a gene respectively. For example flower size: Ss not Sr, or SR.

In part (a) (iii) candidates were asked why the breeding programme had to continue for many generations. This was challenging for many candidates though understanding the stimulus material would have allowed candidates to provide the correct response as it showed that the large flowers and large leaves were only produced after several generations. At the end of the process, both characters were true breeding.



Part (b) (i) was done very well. Candidates were able to state that one advantage of having large flowers is to attract more insects for pollination and having large leaves allows absorption of more light for photosynthesis. Part (b) (ii) was also fairly well done. However, a few candidates did not read the question properly and gave advantage to the plant and not the flower farmer. For Part (b) (iii), candidates were asked to give one other characteristic of the new flower that the flower farmer would want and to say why it would be important to the farmer. This was fairly well done, although a few candidates explained why it was important to the plant and not to the farmer. Many candidates correctly stated the characteristic 'resistance to disease' and that it was important to ensure the crop was not wiped out by disease so the farmer will make more money.

### **PAPER 03 – EXTENDED ESSAYS**

Paper 03 consisted of three sections, each section consisting of two questions from which candidates were to choose one. Candidates were required to write extended answers to the questions. Performance on this paper was unsatisfactory; the mean mark was 21.42 or 35.70 percent. Candidates' performance was marginally depressed when compared with their performance in 2004 where the mean was 22.33 or 37.22 percent.

#### Question 1

This question tested the difference between diffusion and osmosis, the role of osmosis in transport in a plant, the importance of osmosis in controlling diabetes and the reasons for adjusting the diets of patients with malfunctioning kidneys. The question mean was 4 out of a total mark of 20.

In Part (a) (ii) candidates were required to describe two differences between osmosis and diffusion. Very few candidates gave complete comparisons. One common misconception was that only gases diffuse. In Part (a) (ii) they were asked to describe how osmosis is used in transport by a plant. Many referred to the osmotic uptake of water by root hairs from soil solution. No reference was made to the soil solution being less concentrated than the cell sap which allows osmosis to take place; or that water moved from cell to cell across the roots through partially permeable membranes; and from the xylem vessels to the mesophyll cells of the leaves - all by osmosis.

Part (b) (i) of the question presented a challenge to all candidates. The performance was poor. Here candidates were required to explain why osmosis in cells is an important part of the control of diabetes. Candidates were expected to explain that in diabetics blood sugar levels become elevated; blood concentrations become higher than in surrounding cells; water will move out of these cells into the blood by osmosis because their contents are less concentrated than the blood. The cell contents become dehydrated, metabolism is disrupted and the cells may eventually die.

In Part (b) (ii) candidates were required to explain why diabetes is considered a physiological disorder and not a nutritional disease. Most candidates wrote good responses, recognising that diabetes was caused by a physiological breakdown in the functioning of the pancreas and not by poor nutrition.

Part (c) (i) asked candidates why patients whose kidneys had stopped working efficiently were put on strict diets with little salt, very small quantities of meat, beans and peas and given very little water when they were thirsty. It was evident that candidates had some knowledge of kidney function but were unable to interpret the question, or to apply and articulate their explanations with clarity using appropriate scientific jargon. Urea from the metabolism of proteins and a high level of salt and water would increase the work-load of the kidneys. Part (c) (ii) candidates were asked to suggest how a kidney machine is able to 'clean' a patient's blood. This was difficult for most candidates. Few understood that the waste products in high concentrations would diffuse from the blood, across the membranes, into the fluid and that water levels would be adjusted depending on its concentration in the blood relative to that in the fluid.

## Question 2

This question tested the candidates' knowledge of the structure of the red and white blood cells, the role of the white blood cells; the functions of the skin and blood in protecting the body when cut; differences between the skin of a human and the epidermal tissue of a leaf and the role of the transport system of a plant in spreading disease causing organisms throughout the plant. The question mean was 8 out of a total mark 20.

Performance in Part (a) (i), on this part of the question was unsatisfactory. Comparisons were seldom made, although some details of the struc-

ture of red and white blood cells were mentioned. Performance in Part (a) (ii) was fair. Candidates were required to describe the role of white blood cells, but no one mentioned that 'white blood cells confer immunity and immunity may be long-lasting'.

Candidates' performance in Part (b) (i) was poor. They were asked to describe one way in which the skin offers protection. A complete description such as the following was seldom given. The malpighian layer of the skin provides protection from the sun's ultra violet rays. The skin contains sensory cells which respond to adverse stimuli; glands which produce sweat and blood vessels that dilate to prevent overheating of body. In Part (b) (ii) candidates were asked to describe how the skin and blood work together in order to protect the body when it is cut. Candidates were knowledgeable about mechanisms involved in the formation of a blood clot and scab. This part of the question was very well done.

In Part (c) (i) performance was generally poor. Candidates were required to identify two differences between the structure of epidermal cells of a leaf and the human skin. Many could not give two comprehensive differences. They were more knowledgeable about the structure of the epidermal layer of the leaf than the skin. Candidates were expected to make reference to the fact that epidermal tissue is a single tissue while skin is made up of many tissues. The outer covering of the leaf is non-cellular, but the skin's outer covering is cellular. The epidermis of the leaf is made up of living cells but the outer covering of the skin is made up of dead cells. Performance in Part (c) (ii) was satisfactory. Candidates were expected to explain the mechanisms of transport in a plant which would allow a disease to spread. Explanations were not developed in a logical manner, but candidates were able to score some of the available marks.

### Question 3

This question dealt with ecology and the environment. Performance was satisfactory with a question mean of 9 out of a total mark 20.

Performance in Part (a) (i) was generally fair. In some cases candidates confused the physical and biotic factors. When referring to one of the factors, both types of examples were given. Acceptable examples of physical factors included: temperature, soil, wind, rain and humidity. Examples of biotic factors included: predators, herbivores, carnivores, trees/forests, man, bees, etc. Part (b) (ii) required candidates to explain how a biotic factor might affect one of the physical factors in the habitat. This was well done by some candidates but others seemed not to have been

familiar with the concept that a biotic factor could affect a physical factor and vice versa. For example, trees may affect shade, temperature and change humidity. Animal waste will change the soil's nutrient content and texture.

Performance in Part (b) (i) and (ii) was satisfactory. Candidates were required to give two methods of dispersal that brought the plants back to the area and to explain why plants returned before the animals. In a few cases, candidates confused dispersal with pollination but most recognized the importance of plants as producers in food chains and webs and thus their necessity to return before animals.

Performance was again satisfactory. Candidates' were aware that if the soil was damaged plant growth would be affected and consequently animals would not be able to inhabit the area. In Part (c) (ii) candidates were knowledgeable about the long-term effects of loss of a large part of a forest, for example loss of species; extinction of endangered species; and deterioration of soil and air quality.

#### Question 4

This question tested the candidates' knowledge of diseases; their mode of transmission; and the AIDS epidemic. It was the more popular of the pair of questions in Section B, and overall performance was fair. The question mean was 8 out of a total mark 20.

In Part (a) (i) candidates were required to link the frequency of diseases to their methods of transmission. Candidates were unable to give logical responses and merely gave definitions and examples. They did not frame their responses by stating the characteristics of pathogenic diseases cause more persons to have them than inherited diseases. In Part (a) (ii), candidates were required to use their knowledge of genetics to show that heterozygous parents who are carriers for a disease could produce a child with the homozygous recessive genotype where the disease is manifested.

Part (b) (i) sought to test candidates' knowledge of the characteristics of AIDS that cause it to be a deadly disease. While some candidates were aware that HIV affects the white blood cells and the body's ability to fight disease, many simply wrote the symptoms of AIDS without linking to the fact that the body's defence is breached and other diseases become fatal.

In Part (b) (ii) candidates were asked whether they thought it was possible for humans to eventually become resistant to AIDS and to give a reason for their response. Candidates' responses did not focus on the acquisition of resistance through artificial selection but instead mentioned the virus mutating, thus making resistance difficult.

Part (c) asked candidates to agree/disagree with the seizing of plants brought into a country without permission and isolating persons with AIDS. Most agreed that the former was a good practice because the plants could carry infectious diseases. However, they disagreed that persons afflicted with AIDS should be isolated positing that it is inhumane except in cases where persons wilfully spread the disease to others.

### Question 5

The objectives tested in this question included digestion, absorption, enzymatic reactions and the diet. It was the more popular of the pair of questions and performance was satisfactory. The question mean was 7 out of a total mark 20.

In Part (a) (i), candidates correctly identified the products of digestion of bread, eggs and butter. However, in Part (a) (ii) many were unable to state the fate of all the end products of digestion. In many cases only one of the possible responses for each end product was given. Responses such as the excess amino acid being converted to urea or the fatty acids and glycerol being absorbed into lacteals or bloodstream were hardly stated.

Part (b) described a situation where a student investigating the actions of the enzyme lipase places a piece of fat in lipase solution and left the test tube in an air conditioned room. Candidates were asked to explain why the student did not get the results he expected. Many focused on the temperature and only few mentioned pH and size/surface area. Further, even when one factor was given, no explanation was provided for the enzyme's inactivity as the candidates were required to do. This underscores candidates' inability to interpret questions and to provide logical, complete responses.

In Part (c), candidates were knowledgeable about the reasons why people should reduce fat in the diet and why fat should not be completely eliminated from the diet. Fat as an energy source and for formation of adi

pose tissue were frequently mentioned while its importance for the production of necessary organic substances was not stated.

### Question 6

This question examined candidates' knowledge of types of systems in the human body – coordination and reproduction and the role of hormones. Generally candidates' performance was satisfactory. The question mean was 6 out of a total mark 20.

In Part (a) candidates were required to identify two systems in the human body that are responsible for co-ordination and explain the reason why co-ordination is important to living organisms. Many candidates mentioned only the nervous system. Very few mentioned the endocrine system. A common misconception was that the blood system is also involved in co-ordination. Performance in Part (a) (ii) was fair. However, a large number of candidates gave the reason why co-ordination is important to living things as the need to find food, a mate and protection instead of mentioning - detection of changes in the external and internal environments and responding appropriately to changes.

For Part (b), a discussion was required on how low oestrogen levels would affect a 7 year old girl's future life. While performance was fair, some candidates failed to give in-depth analysis of the problem in a logical, cohesive and clear manner. Their responses were limited. Candidates were expected to mention the abnormal development of the sex organs; effect on the menstrual cycle and possible inability to produce children.

Part (c) (i) candidates were asked to state and explain which hormone was present in greater quantities in birth control pills. This was fairly well done. Most candidates correctly stated that progesterone was the hormone and that it prevented ovulation. However, very few mentioned that the hormone mimics pregnancy. In Part (c) (ii), a situation was presented where an ovum was removed from one woman, fertilised in a test tube and the embryo implanted in the uterus of another woman. Candidates were required to suggest three problems that may be associated with the procedure. Performance was fair and the common responses included rejection of the embryo and parental rights. Few mentioned the difficulties associated with harvesting the eggs.

## PAPER 04/2 – ALTERNATIVE TO SBA

This paper consisted of three compulsory questions, which tested the practical skills areas: planning and design; observation, recording, reporting; analysis and interpretation; drawing and measurement and manipulation. Performance was generally below the required standard.

### Question 1

In this question candidates were expected to draw and label a chive plant, make detailed observations on a single leaf, plan and design, carry out and report on an investigation; and draw conclusions based on additional information provided. Performance was less than satisfactory. The question mean was 12 out of a total mark of 30.

In Part (a) the performance was poor. Drawings were not accurate; and lines were fuzzy. Lines used for labelling were not drawn with a ruler and were too short. Labels were not printed. The title, magnification and view of the drawings were seldom stated and where stated were incorrect. For example, some candidates wrote 'A Diagram of Specimen A' instead of 'Drawing of the External View of a Chive Plant'.

Part (b) of the question required candidates to give a description of a leaf of the plant. The responses were generally vague; few candidates identified the longitudinally running veins and the white rolled leaf base.

The performance on Part (c) (i) of the question was satisfactory, although there was seldom any logical sequencing in the method. Many candidates observed a negative starch test, yet inferred that starch was present. They obviously made some assumptions about the expected results. In Part (c) (ii) candidates were expected to perform a test for a reducing sugar using Benedict's solution and they were to compare their results with those in Part (c) (i). This was difficult for most candidates. They did not know how to use the new information given along with their previous findings to come to a logical conclusion. The expected response was - a positive result for non-reducing sugar was obtained, there was no starch in the leaf of the chive plant therefore sugar (sucrose) is produced in photosynthesis and not starch.

### Question 2

In this question candidates were given diagrams of several pieces of equipment and materials and were asked to show by drawing how one would



assemble them to demonstrate the positive and negative response of small organisms to light and dark conditions. Performance on this question was poor.

Examiners expected candidates to show the Petri dishes divided into four quadrants, each with a different set of conditions created with the materials illustrated in the figure. Very few candidates were able to provide the expected response. Many divided the dish into only two quadrants while others had no divisions at all. In some cases, the wood lice were placed in the container that held the water. Most candidates were unfamiliar with the procedure and could not design an experiment using the apparatus and materials provided. In the view from above examiners expected candidates to use a circle to represent the Petri dish. The circle would be divided into four quadrants of equal size with materials to provide the following conditions:

- damp and dark (moist cotton wool in the quadrant and covered with black paper)
- damp and lighted (moist cotton wool in the quadrant and uncovered)
- dry and dark (dry cotton wool in the quadrant and covered with black paper)
- dry and lighted (dry cotton wool in the quadrant and uncovered)

The side/lateral view would show a rectangle to represent a cross section of the Petri dish. The gauze would divide the rectangle into lower and upper halves and the petri dish cover would be situated over the dish like a wide 'n'. The lower section would be divided into two parts, right and left of centre, with moist cotton to the left or right and dry cotton wool on the other side. Paper would be drawn over one half of the Petri dish cover. The organisms would be placed near the centre of each diagram, resting on the wire gauze above the quadrants.

In Part (b) (i), candidates were expected to suggest why all the organisms did not go to the dark, damp area. Few provided the following expected responses: sensory system not working well; organisms damaged during handling; damaged wood lice had difficulty moving or died. In Part (b) (ii) more candidates were able to obtain marks by correctly stating the risks to the organisms that were unable to respond by moving towards dark, damp areas. The question mean was 3 out of a total mark of 12.



### Question 3

In Part (a) (i) not enough candidates were able to take correct readings from the three measuring cylinders. They also had difficulty doing basic calculations to determine the proportions of soil particles in Plot I. In Part (a) (iii) precautions, such as ensuring glassware was clean, were not credited. Examiners expected precautions such as: ensure same volumes of water used; shake mixture vigorously; allow same time for settling. The term hypothesis was not understood by all, since some candidates gave the aim of the experiment rather than a possible explanation for the observation which could be tested.

In Part (b) (i) candidates had difficulty deducing the aim of the investigation and linking it to a possible observation for Part (b) (ii).

Part (c) required candidates to describe a method to show that the amount of water the soil holds affects growth of the plant. Candidates lost marks if they merely outlined the method. They needed to pay attention to details such as controlling variables. For example: specifying soil type and volume; indicating the manipulated/independent variable (the amount of water) and responding/dependent variable (amount of growth). Some candidates simply stated that they would measure the growth rather than the indicator of growth such as height or number of leaves. The question mean was 5 out of a total mark of 18.

**CARIBBEAN EXAMINATIONS COUNCIL**

**REPORT ON CANDIDATES' WORK IN THE  
SECONDARY EDUCATION CERTIFICATE EXAMINATION**

**JANUARY 2006**

**BIOLOGY**

**Copyright © 2006 Caribbean Examinations Council ®  
St Michael, Barbados**

**BIOLOGY**  
**SECONDARY EDUCATION CERTIFICATE**  
**JANUARY 2006**

**GENERAL COMMENTS**

The January 2006 examination in Biology consisted of four papers:

- Paper 01 – Multiple Choice
- Paper 02 – Structured Essay Questions
- Paper 03 – Extended Essay
- Paper 042 – Alternative to the School-Based Assessment

Performance of candidates in this examination was fair and there still remains the need for improvement in preparing for the examination. Particular attention should be paid to the following comments in preparing candidates for the examination if improvements are to be realised.

- Candidates must improve their test-taking skills. This includes practice in reading questions carefully and planning responses so that answers are organized in a logical and cohesive manner.
- Candidates continue to waste a lot of valuable time providing irrelevant information in the essays. They should focus on key words such as ‘describe’ and explain when reading the questions and be guided by the mark allocation and quantitative descriptors within the text of the question as far as possible.
- There was also the question of choice of terminology and descriptions provided. Familiarity with biological jargon allows candidates the opportunity to express themselves more accurately and reduces errors caused by oversimplification.
- Candidates should pay more attention to the stimulus material provided in the questions, especially in Paper 02. The stimulus material is meant to guide the candidate to the expected responses. Too often candidates responded by providing obscure information on the topic that did not relate to the scenario presented.
- More emphasis should be placed on practical skills and the candidates’ ability to demonstrate these skills in responding to questions on the Alternative to SBA paper. Too many candidates seemed unfamiliar with basic laboratory equipment and material even the simplest of biological/scientific methods. Candidates demonstrated particular weakness in identifying precautions and limitations of an experiment, as well as in stating aims and formulating hypotheses.

## **DETAILED COMMENTS**

### **PAPER 01 – Multiple Choice**

Paper 01 consisted of 60 multiple-choice items. Performance on this paper was similar to that of 2005. The paper tested candidates' knowledge across all sections of the syllabus.

Some of the topics that were *most* problematic for the candidates were:

- Aspects of ecology including feeding relationships and food chains
- Cell structure and function
- Specifics of photosynthesis
- Specifics of respiration
- Distinguishing diffusion from osmosis
- Identify variables in an investigation
- Phloem structure
- Structure of the human skin
- Reflex arc
- Aspects of growth in plants and animals, for example, role of auxins
- Aspects of nutrition
- Aspects of respiration and excretion
- Bones and their functions
- The eye as a receptor and effector organ
- Metabolic rate and effect on the body temperature
- Homeostasis
- Distinction between meiosis and mitosis
- Distinction between population and community
- Xerophytic characteristics in plants

### **PAPER 02 – Structured Questions**

Paper 02 consisted of five short-answer structured questions of which the first was the data analysis question worth 30 marks. This paper tested all profile skill areas identified in the Biology syllabus.

Candidates were able to attain marks across the allotted range for all questions, so it is evident that all marks on the paper were available. However, for more candidates to give their best performance, attention must be paid to observations and suggestions the Biology examiners have repeatedly noted. In particular, candidate attention is drawn to the use of the stimulus material in responding to the questions and the guidance provided by the spaces allotted to each question – answers should relate to the stimulus material and should be kept within the allotted spaces. Candidates must note that they are not required to repeat the questions to begin their responses.

## Question 1

This question tested a range of experimental skills associated with investigating the process of decomposition and the use of natural fertilizers. It also assessed candidates' knowledge of transpiration experiments and food tests. Included in this question were ways of representing data and methods of investigation. Candidate performance on this question was disappointing.

Part (a) (i) required candidates to construct a graph based on data on the decay of leaves presented in a table. This was fairly well done, although axes were sometimes inaccurate. Candidates often omitted the title of the graph or extended the graph rather than work within the grid presented. These resulted in unnecessary loss of marks. Part (a) (ii) required candidates to provide precautions to be taken in setting up the investigations for which the data were provided. Performance was fair, many candidates failed to realize that precautions relate to those facts that impact on the accuracy of the results of the investigation, such as, *using identical starting mass (weight), replications and maintaining the temperatures throughout the experiment*. Candidates mistakenly referred to exercising care when handling equipment to prevent injury.

Part (b) asked candidates to draw conclusions from and offer explanations for the data presented. Candidates generally indicated that increasing temperature seemed to increase the rate of decomposition, which was the expected response in Part (b) (i), but they often repeated the response for Part (b) (ii), which asked for an explanation for the conclusion drawn in Part(b) (i). Candidates were expected to indicate that with higher temperature there would be microorganisms and more rapid decay or some similar explanation. Part (b) (iii) was also poorly done. Candidates were required to determine whether or not decomposition would continue at 80°C. Both negative and positive responses were acceptable with an appropriate rationale; for example, a positive response with the reasoning that *living organisms were involved, enzymes present would be deactivated at that temperature or organisms would be killed*; A negative response with the reasoning that *the temperature was not high enough to kill microorganism and many were known to survive much higher temperatures*.

Part (c) asked candidates to provide some points to promote the use of natural fertilizers. This part of the question was very well done. Candidates generally could provide valuable information about using natural fertilizers as opposed to chemical ones.

Part (d) dealt with experimental skills related to transpiration. This part of the question was poorly done. Very few candidates seemed to be familiar with a potometer and were unclear about how to prepare the material for conducting the investigation required in Part (d) (i). Few candidates could describe a limitation of the investigation required in Part (d) (ii), or where to read the bubble required in Part (d) (iii). They also had difficulty estimating the rate of transpiration in Part (d) (iv) or were able to give the reasons why the estimate may not be accurate in Part (d) (v). The part of the question which was very well done was identifying a factor that affects the rate of transpiration required in Part (d) (vii).

Part (e) required candidates to describe tests to determine two nutrients in a particular fruit. Candidates gave a fair performance on this part of the question. Although they were familiar with food tests generally, several gave misinformation or were not sure what the results ought to be for a particular test.

## Question 2

This question examined candidates' knowledge of structure and function of the human heart and heart disease. Candidate performance on this question was generally good.

In Part (a) (i), candidates were asked to label the left atrium and left ventricle. This part of the question was quite well done, although some candidates labeled the 'right' instead of the 'left' of the diagram and some mixed up atrium and ventricle. In Part (a) (ii) of the question, candidates were required to use arrows on the diagram to show the direction of blood flow from the pulmonary artery to the aorta. This part of the question was not well done. Many candidates simply showed the movement of blood through the heart and did not gain full marks. Too many candidates did not know the direction of blood flow in the heart although they were able to indicate on the diagram the flow of blood leaving the heart. In Part (a) (iii), candidates were required to identify structures in the heart that ensure blood flowed in one direction only. Candidates performed well on this part of the question, especially as they were not penalized for the incorrect spelling terms, such as, 'mitral', 'bicuspid', 'semilunar' and 'tricuspid';

In Part (b), candidates were given a graph showing the number of deaths due to heart disease in smoker and non-smokers. In Part (b) (i), candidates were asked to draw a conclusion from the data. Performance on this part of the question was fair. Most candidates gained only half the allotted marks as they indicated the death rate was higher in smokers compared with non-smokers, but they failed to mention heart disease. A good response was:

*The rate of death due to heart disease, especially at an older age, is higher among smokers than non-smokers.*

Part (b) (ii) required candidates to suggest why smoking may contribute to heart disease. This part was not well done. Candidates erroneously suggested that 'smoking clogs the heart' or that tar and nicotine were deposited in the blood vessels. They failed to make the link between the functioning of the lungs and that of the heart. It was expected that candidates would have noted that smoking damaged the lining of the lung, reduced its oxygen-carrying capacity and related this to the heart having to work harder and the attendant rise in blood pressure.

In Part (c), candidates were required to identify factors, besides smoking, that could cause the heart to malfunction. Candidates performed well on this part of the question. They provided a range of good responses including, *poor diet/too much fat/cholesterol, stress and lack of exercise. Also included were genotype, old age and drug abuse.*

### Question 3

This question tested candidates' knowledge of the structure of a seed that has started germinating and the changes which take place within the seed during the germination process. Candidate performance on this question was quite disappointing given that these are fundamental concepts in the study of Biology. Many candidates omitted Parts (a) and (b) of the question.

Part (a), when known, was fairly well done by the candidate population. Candidates were able to recall the parts of the seed and were even able to provide annotations. Candidates should know that the rules for labeling always apply to biological drawings, for example, labeling to one side as far as possible, using straight lines drawn with a ruler for labeling lines and no arrow heads. Candidates are reminded that the **embryo** consists of the 'plumule' and 'radicle'. Far too many candidates seemed unaware of this structure. Candidates also misspelt a number of important terms which make it difficult to award the marks. Some candidates wrote 'helium' for 'hilum' or 'testes' for 'testa'. Since these are correct terms in other circumstances, one cannot assume that the candidates know the correct terms.

Part (b) required candidates to indicate the changes that took place in the seeds to bring about the growth of the radicle. This part of the question was poorly done. The majority of candidates failed to indicate the changes that took place within the seed and showed many misconceptions about the initiation of the process of germination. Misconceptions included "...force of water...bursting the seed coat"; 'gravity pulling the embryo out' as well as the water providing nutrients for the elongation of the radicle. A good response would have included '*activation of enzymes, converting food to building material/ releasing energy; translocation of food material to the growth point*'.

Part (c) required candidates to explain the importance of seeds having a large food store. Candidate performance was poor partly due to inappropriate reading of the question, misconceptions and to the provision of incomplete responses. One misconception was that the seed provided a means to '... excrete food'. Candidates often confused 'storage in seeds' with 'storage in plants' generally. It should be noted that storage in seeds is a subset of general storage in plants for specific purposes of: *dispersal/ avoidance of overcrowding; initial growth of seedlings/germination; food availability before the start of photosynthesis; weather/unfavourable climatic conditions*.

### Question 4

This question examined the candidates' knowledge of the male and female reproductive system, fertilization and female sex hormones. Candidates seemed generally familiar with this area of the syllabus and performed credibly.

In Part (a), candidates were required to label on the diagram provided structures involved in gamete production and transfer. This part of the question was well done with the majority of candidates being able to identify the relevant structures. However, many candidates labeled all the parts of the reproductive systems illustrated and not just the structures involved in gamete production and transfer as the question required

Part (b) of the question was well done. The majority of candidates were able to place an X on the diagram to mark the place where fertilization occurs – the upper third of the fallopian tube – which was required in Part (b) (i). They were also able to map out the route that a spermatozoon must travel to fertilize an egg, in Part (b) (ii). Candidates generally indicated the correct sequence as: *testis-epididymis-spermduct-urethra-vagina-uterus-oviduct*. For Part (b) (iii), candidates gave a range of acceptable responses for a fertilized egg to not result in a successful pregnancy. These included; *ectopic pregnancy; inability of the womb to accept the fertilized egg; natural abortion; artificial abortion; presence of an IUD; use of abortion pill*. Expected responses also included: *fertilization occurring too low down the oviduct; defective embryo*.

Part (c) dealt with female hormones. Many candidates knew the major reproductive hormones and gained full marks in Part (c) (i) of the question. However, candidate performance in Part (c) (ii), which asked how the hormones enabled successful reproduction, was indeed poor. Candidates seemed unable to use their knowledge of the processes involved in the reproductive cycle to provide an adequate response to this question. They were expected to indicate aspects of the role of the hormones such as: *oestrogen ensures that the egg develops and is released at an appropriate time or it repairs the uterine lining; progesterone ensures preparation of the uterus for implantation or maintains pregnancy; the events in the cycle are coordinated over a regular period facilitating fertilization/implantation*.

#### Question 5

This question examined candidates' knowledge of ecology. Candidates were asked about biotic and abiotic factors and how organisms related to one another in their environment as well as the impact of certain human activities on the natural environment. Candidate performance on this question was good.

Part (a) of the question asked candidates to identify biotic and abiotic factors illustrated in diagram given (Part (a) (i)), and to suggest ways in which the identified factors interact, in Part (a) (ii). Candidate performance on this part of the question was relatively weak as many candidates were unable to correctly distinguish the biotic factors as the living organism and the abiotic as the physical environment. Many candidates mistakenly described biotic factors as animals and abiotic as plants. Generally, candidates who could not distinguish between biotic and abiotic factors could only offer that the biotic depended on the abiotic in Part (a) (ii). However, some candidates indicated such relationships as “tadpoles feed on floating water plants” or that “plants gave off oxygen which is used by the animals”.

Part (b) was best answered by the candidates. It asked candidates to indicate some precautions to be taken when erecting a new settlement near a pond so as to minimize the impact of human activity on the pond as a natural habitat. Part (b) (i) was appropriately answered by the majority of candidates who were able to predict the effect of sewage or toxic chemicals on the life of organisms inhabiting the pond, and also the effect of human activities such as fishing and boating. Many candidates also mentioned the effect of introducing new organism into the pond which could disrupt its ecological balance.



Part (b)(ii) asked for a reason for algal bloom in the pond after heavy rains. While many candidates linked the phenomenon to the *availability of extra nutrients through the runoff of fertilizer or sewage*, several candidates had no conception of ‘algal bloom’ and thought that the algae produced flowers and were spread by seeds, or that the rain brought seeds or provided more water for the algae to grow. Part (b) (iii) was fairly well done. Candidates were asked to explain the consequence of the rapid increase in the algae population. Many candidates were able to see that increased algal growth would create problems with respect to the availability of light or oxygen or both.

### PAPER 03 - Extended Essay

Candidates demonstrated a continuing ability to write at length about biological events, principles and concepts. However, candidates missed key words in the questions and provided answers which were off the point. It is thus reiterated that candidates should be advised that *the reading time should be used to read through each question carefully, highlighting key words on which the question hinge, so that they would be less likely to misread and misinterpret questions. The reading time should also be used to plan their responses so that they are more likely to stick to the relevant topics.* It is clear that much time is spent on teaching and learning the content of the syllabus. However, more attention needs to be paid to developing important examination techniques which allow candidates to make the best use of what they know.

#### Question 1

This question tested candidates’ knowledge of the process of photosynthesis, the suitability of the leaf for photosynthesis, and the ability of plants to survive loss of their leaves. The consequences of loss of crops to pests and effective methods of controlling swarming insects were also examined in this question. Candidate performance on this question was fair.

In Part (a) (i) candidates were required to describe the process of photosynthesis. Although candidates’ responses showed a general familiarity with the concept of photosynthesis many failed to gain full marks as they omitted or incorrectly described significant aspects of the processes involved. Candidates were expected to outline major steps in the photosynthetic process including: *chlorophyll traps sunlight; sunlight is converted to chemical energy; glucose and oxygen are produced; sunlight splits water; carbon dioxide combines with hydrogen/water; oxygen is given off.*

Part (a) (ii) asked candidates to identify characteristics of the leaf important to photosynthesis and show how the characteristics mentioned facilitated photosynthesis. This part was fairly well done, although many candidates failed to make the link between the structure and how this was suited to its particular function. Candidates were expected to refer to the *thinness of the leaf* and its facilitation of *light penetration*; or that *the flattened structure* of the leaf afforded a *larger volume or surface area to volume ratio for diffusion*; or that the *network of veins* allowed for *transport of assimilates* throughout the leaf; or that the *stomata* were adapted for *rapid diffusion during favourable conditions*. In Part (a) (iii), candidates were to suggest how it was possible for a plant to survive after losing all its leaves. This presented candidates with a fair level of difficulty. Candidates seemed to forget that the *roots were still alive* and thus had the *potential for growth*; *nutrients* were still available from *stored food*, or that the *root and stem had food reserves* for such conditions.

Part (b) dealt with social and economic implications of the loss of leaves in a crop. Part (b) (i) asked to explain consequences to a farmer if his crop is attacked by a swarm of locusts. Many candidates failed to see that the question continued the exploration of the challenges to the plant when it loses its leaves. Many failed to indicate that photosynthesis would not occur and that productivity of the plants and thus the crop would be reduced or completely destroyed. The result of loss of productivity to the farmer would result in economic loss to the farmer due to direct *loss of income, loss of investment, or loss of man hours*. Part (b) (ii) asked candidates to suggest why spraying the locusts with an insecticide would be ineffective. Candidates missed a good opportunity to use the material given to help construct their responses. Many candidates did not realise that because the insects were in very *large numbers, in motion* and were *moving rapidly*, would have rendered the spraying ineffective, as would be the unpredictability of the swarming and the fact that it would take the insecticide time to act. In Part (b) (iii), candidates were asked to explain two methods that could be used for controlling insect pests. Candidates relied heavily on their reading around the topic and provided many good responses including biological control. However, it was noted that the terms “herbicide”, “insecticide”, “pesticide” and “fertilizer” were all used interchangeably. Candidates are advised that these terms, like so many in Biology, have specific meaning and they must be used consistent with their respective and specific meanings.

## Question 2

This question tested candidates’ knowledge of the processes involved in mitosis and cloning. Candidate performance on this question was fair. As a general observation some candidates still confuse “mitosis” with “meiosis”.

Part (a) (i) required candidates to describe the process of mitosis and explain its significance. Many candidates displayed some knowledge of the process of mitosis, although this was quite superficial in some instances. Candidates often knew the names of the stages (which is not a syllabus requirement) but could not correctly describe what occurred at the stages. It should be noted that for mitosis (and meiosis) candidates are specifically required to demonstrate understanding of what is happening to the genetic material in the cells at the various stages, for example *duplication of the genetic material/ chromosomes, chromosomes become visible, chromosomes move to the centre of the cell, chromatids pulled to poles, two sets of chromosomes at opposite ends of cell, cytoplasm divides, new cells have same number of chromosomes as parent cell*. Many candidates displayed satisfactory knowledge of the following concepts with regard to mitosis, including in their responses: *it occurs in body cells; identical daughter cells are formed; daughter cells have the same number of chromosomes as parent cell*. In Part (a) (ii), the response of many candidates to identifying parts in plants where mitosis occurred was vague, for example roots or shoot instead of ‘shoot tip’ and ‘behind root tip’. No candidate mentioned cambium as a place in plants where mitosis occurs.

Candidates gave relatively satisfactory answers in Part (b), which asked them to explain to farmer two advantages of having a field of ‘cloned’ sugarcane. They explained that desirable characteristics like resistance to disease and high sugar content would be maintained.

Performance on Part (c) (i) was weak. Very few candidates were able to explain that the *nucleus of the somatic cell had full complement of chromosomes so it could replace that of the egg*. They also did not grasp the concept that the *clones would have identical features of the parents*. Responses to Part (c) (ii) were generally vague with only a few candidates showing a clear understanding that rejection of donor organs would result as a consequence of action of the immune system and that this would be less likely if the clone tissue was from ‘self’ and not from a ‘foreign’ or different organism.

### Question 3

This question tested candidates’ knowledge across a range of topics including the structure and function of human lungs, and phloem as well as fruit formation and the importance of fruit preservation. This question was not very well done compared to the performance on the counterpart question in this section. Candidates performed better on knowledge component of the question but not as well as on the knowledge aspects.

Part (a) asked candidates to describe four features of human lungs which make them efficient for gaseous exchange. Generally, candidates were aware of the major features of the lung but were challenged in indicating what about these features allowed the lung to function efficiently. They were expected to indicate that *numerous alveoli and many capillaries at the respiratory surface allowed for a large surface area to volume ratio for many gaseous exchange; alveolar and capillary walls are one cell thick – thinness; mucus of alveoli kept the gaseous exchange surface moist; copious blood supply, network of capillaries carrying blood; relationship between the alveoli and blood contribute to the establishment of an appropriate diffusion gradient*.

Parts (b) and (c) addressed aspects of plant structure and function. Candidates’ performance on these parts of the question reflects the continuing weakness of candidate knowledge of plant biology. In Part (b) (i), candidates were required to show how its features help the phloem to function efficiently. This part of the question was not well done. Candidates were expected to refer to any one of the following; *reduced number of organelles in the sieve tube; arrangement of the sieve tubes end-to-end; companion cell providing energy to sieve tubes; mechanism – sieve plates with holes containing cytoplasmic strands – to help transport food*. Part (b) (ii) asked candidates to suggest how the functioning of the phloem might change during fruit formation and development. This part was also not well done. Candidates were expected to refer to one of the following: *increased transport of food to site of fruit development; increased sugars and other storage products, companion cells providing more energy*.

In Part (c) (i), candidates were asked to suggest why fruits are sometimes preserved by coating with wax, while in Part (c) (ii), they were asked to identify ways in which any three plant processes affect fruit formation and development. Candidate performance on this part of the question was fair. Candidates were expected to include in their responses to Part (c) (i) that waxing *reduced the capacity for gaseous exchange; reduces water loss; results in lower metabolic rate or reduced respiration rate*.

For Part (c) (ii), candidates were to select from any of the plant processes that might affect fruit formation including *transpiration, photosynthesis, gaseous exchange, transport by the phloem or reproduction* and indicate how the process selected might have an impact on the formation of the fruit. For example, with respect to transpiration a good response would refer to the effect on: *uptake of water by the roots; movement of water from roots to leaves; increased water supply for tissue formation or metabolism;* or transport by the phloem: *movement of assimilates from the leaf to the fruit,* or reproduction: *increased activity/mitosis.*

#### Question 4

This question examined candidates' knowledge of the impact of human activity on the environment and in turn on the spread of certain diseases. It was generally well done, with the majority of candidates attaining full marks on the knowledge components of the question. A few candidates obtained full marks for the entire question.

Part (a) (i) asked candidates to describe two ways in which human activity negatively impacts the environment. This part of the question was generally well done. Candidates indicated a variety of activities especially related to agricultural practices such as the use of chemicals and improper garbage disposal. In Part (a) (ii), candidates were asked to give reasons, apart from pollution of water courses, why government might be concerned about increasing the squatter communities.

Part (b) asked candidates to suggest why burning garbage might be a harmful practice and to give two alternative methods of garbage disposal. Candidates readily associated the burning of garbage with air pollution and aggravation of respiratory problems in humans in the response to Part (b) (i). Many were able to give a satisfactory response to Part (b) (ii), including the burying of garbage in landfills or dump sites. Their responses could also have included the *use of compost heaps* for plant material or use as *manure* and the *recycling of paper, plastic and glass.*

Part (c) asked candidates to name a couple of diseases caused by pathogens and to suggest why the occurrence of AIDS is rarely higher in a crowded community than in a middle class neighbourhood. Candidates were generally able to identify diseases caused by pathogen and gained the marks allotted to Part (c) (i). However, Part (c) (ii) was not at all well done. Candidates generally failed to use the information given in the question. For instance, they did not recognize that the description of the 'crowded' community was a clue to the spread of many pathogenic diseases, and many candidates seemed to think that 'rarely' meant 'really' and thought the occurrence of AIDS was in fact higher in 'poor', crowded communities.

#### Question 5

This question, the more popular the of questions in Section C, tested candidates' knowledge of living organism in their environment including food chains and webs in selected habitats, factors that affect the status of habitat and the roles of organisms in maintaining the equilibrium of a habitat. This question was not well done.

In Part (a) (i), candidates were required to construct for a named habitat a food chain with four trophic levels. Although most candidates were able to perform fairly well on this part of the question, several failed to identify the habitat as required and some constructed a food web rather than a food chain as the question asked. It was expected that candidates would have identified the habitat, include appropriate trophic levels, draw arrows in the right direction and select appropriate organisms for the habitat. In Part (a) (ii), candidates were asked to explain the importance of decreasing numbers of organisms at each successive trophic level. This part of the question was not very well done. Candidates were expected to include in their responses: *provide for successive levels; risk of running out of food; decreasing amount of energy available successively; the system will become unbalanced; organism will cease to exist.*

Part (b) asked candidates to provide explanations for certain occurrences in food chains and webs. In Part (b) (i), the explanation was for the fact that many of the largest animals in the world are herbivores. This part of the question was not well done. Many candidates explained how herbivores were adapted. Responses were expected to show that herbivores are nearer the producers in the food chain; more energy is available to them; larger quantities of food are *available to them*; and/or *they expend less energy hunting*. In Part (b) (ii), the explanation was for the fact that carnivores have multiple sources of food. This part was also not very well done. Many candidates believed that carnivores having multiple sources meant that they eat both plants and animals and that by having multiple sources of food they will get different nutrients. However, candidates were expected to consider that it was *difficult to hunt animals; preys move/flee; increase chances of a steady diet; more food becomes available.*

Part (c) asked candidates to show that different types of organisms performing different functions are important for a habitat to be in equilibrium. Candidates did not perform well on this part of the question. Candidates tended to list various organisms in the habitat without identifying the different types of organisms and how they functioned in keeping the habitat in equilibrium. Candidates were expected to name the organism or type of organism and give a description of their role in maintaining equilibrium in the habitat. For example, *producers – provide food/energy to the system; predators – feed on prey/control number; mutualistic relationship – one helps another/both benefit; parasites – help control numbers of hosts; decomposers – recycle nutrients.*

## Question 6

This question examined candidates' knowledge of the nitrogen cycle, of how the body deals with nitrogenous waste and how certain human activities affect natural cycles.

Part (a) required candidates to draw a cycle to illustrate the role of four types of bacteria in the nitrogen cycle. Some candidates were very familiar with this part of the Biology syllabus and were able to provide adequate responses. Many candidates, however, while they could name at least three types of bacteria were unable to correctly identify their roles in recycling nitrogen. Many candidates ignored the role of putrefying bacteria that cause decay in converting nitrogen in dead bodies, excreta, and egested materials into ammonia and ammonium compounds.

Part (b) (i) required candidates to explain how the human body dealt with excess nitrogenous compounds in the blood. Many candidates answered this section adequately although a few confused the roles of the liver and kidneys in the production and removal of urea from the blood. In Part (b) (ii), candidates were asked to explain how nitrogenous waste, from humans was processed in the nitrogen cycle. A common error made by many candidates was to include faeces as a nitrogenous waste compound. Candidates were expected to indicate: *urea eliminated via urine; broken down to ammonia; role of putrefying bacteria; process occurs in soil; move to next stage of cycle/converted to nitrates.*

Part (c) required candidates to suggest three effects of burning large tracts of forest on the nitrogen cycle. Most candidates could suggest at least one effect. Some who might not have read the question properly suggested effects on the carbon cycle rather than on the nitrogen cycle as asked. Candidates were expected to include in their responses: *trees use nitrates to make proteins; less nitrates absorbed from soil; less fixing of nitrogen; less nitrogen returned to air; reduced activity of bacteria* and so on.

### **PAPER 042 – Alternate to SBA**

This paper assessed all the practical skills required of biology students. It is quite clear that too many candidates are unfamiliar with biological techniques and methods. Candidates continue to display weak practical skills especially in planning and designing, manipulating and describing methods of experiments and in drawing conclusions from data. These observations suggest that teaching for developing practical skills must include actual experimenting and investigating scientific phenomena, discussions, explanations and rationalization of procedures and out comes on the part of students so that they become capable of developing and manipulating experiments and experimental data on their own.

#### Question 1

This question required candidates to demonstrate practical skills of drawing, measuring and planning and designing. In Part (i) of the question, candidates were to measure the length of a hibiscus flower, and in Part (ii) make a drawing only (no labels were required) of the specimen. Several candidates did not recognize that measuring the length of the flower was important in providing the magnification of their drawing to be done in Part (ii). Further, many candidates did not make the distinction between the ‘flower’ and other parts of the plant provided. They measured and drew the leaves, buds and stems present for these parts of the question. Candidates need to recognize that a ‘flower’ in the language of Biology refers to the reproductive structure. With respect to the actual drawings, candidates generally did not produce the expected standard. In fact the standard of drawings shown by candidates was well below acceptable levels. Candidates must be aware that there are rules for biological drawing to which they must adhere. Some of the problems observed that relate to the rules include:

- Use of pencils that were too soft so that it was not possible to draw clean, clear lines
- Inaccurate representation of numbers of parts such as petals

- Calling the drawing a ‘diagram’. ‘Drawings’ are made from live or actual specimens
- Inability to correctly state the magnification of the drawing or to provide a suitable title. Errors related to magnification included the use of units such as ‘cm’; indication 0 magnification for a drawing of same size as the specimen; not writing the magnification correctly, for example, “x1” or “x1.5”.

Part (iii) of the question required candidates to dissect the flower to expose its essential organs and produce a drawing of a cross-section of the ovary. Candidates performed poorly on this question as many were unable to accurately represent the five sections of ovary observed in cross-section with two lines of ovules attached to the central placenta. The term ‘cross-section’ seemed unfamiliar to a large section of the central population as many cut and presented a longitudinal view of the ovary. Part (iv) asked candidates to describe the fruit that could develop from the ovary they observed. The vast majority of candidates failed to recognize the relationship between the ovary and the fruit in trying to predict what the fruit would look like. An acceptable response included the fruit having many seeds in compartments. Part (v) asked candidates to describe a test to show that the leaves of the hibiscus are organs of photosynthesis. This part of the question was fairly well done. However, a common misconception involved the role of de-starching the leaf. Many candidates de-starched the leaf but failed to subject it to photosynthesizing conditions in order to prove that it could produce starch.

## Question 2

This question dealt with enzyme activity and respiration. Although it was generally well done there were some sections that posed difficulties to most of the candidates.

In Part (a), candidates were expected to study diagrams showing the reaction between catalase and hydrogen peroxide which produce water and oxygen. In Part (a) (i), candidates were required to state the aim of the investigation. They were generally able to provide an appropriate aim of the investigation. However in Part (a) (ii), in which candidates were required to identify the gas given off and to state its importance, they had great difficulty giving clear and precise responses. Very few candidates seemed to understand the importance of reaction and merely restated the aim. Among the correct responses were ‘*conversion of toxic hydrogen peroxide into safe oxygen and water*’ and ‘*the decomposition of poisonous hydrogen peroxide into harmless water and oxygen*’. In Part (a) (iii), candidates were asked to suggest how the liver extract had been prepared for use in the investigation. Many candidates were unable to give practical suggestions indicating a lack of experimental knowledge. For example, in some cases the responses included killing the animal. However, there were a few exemplary responses; one candidate stated that ‘*A piece of liver should be ground up using a mortar and pestle*’. The paste should be mixed with distilled water. This mixture should be filtered. The solution obtained would be your liver extract’. Part (a) (iv) of the question required candidates to indicate a precaution that should be taken in obtaining pure, active liver extract. Most candidates were able to obtain the marks allocated as they indicated that the liver should be fresh and free of contamination.

Part (b) of the question dealt with the conditions required for the activity of digestive enzymes. Part (b) (i) and (ii) were generally well done. Candidates generally correctly identified the pH for enzyme activity in the mouth and stomach and indicated that temperature is another factor that could affect enzyme activity. However, Part (b) (iii), which required candidates to design an experiment to show that different conditions are required for optimal reaction rates to pepsin and amylase, was not at all well done.

Many candidates varied both pH and temperature and demonstrated other deficiencies in experimental skills. Many candidates failed to indicate obvious experimental techniques such as, using the same concentration of substrates and enzymes, a control, and removal of samples at intervals.

In Part (c) (i), candidates were given diagrams of several pieces of equipment and materials and were asked to show by drawing how one would assemble them to demonstrate that a gas is a product of respiration in small organisms. Only a small percentage of the candidates knew how to assemble the apparatus. It was apparent that some candidates were aware of the apparatus but did not understand its application in respiration. In Part (c) (ii), few candidates correctly stated that an additional piece of apparatus required for the investigation was a pump. Performance on Part (c) (iii) was generally acceptable although only a few candidates were able to go beyond stating that the potassium hydroxide was needed to remove carbon dioxide to state that it should be removed from the air going to the mammal or that it was used as a control. Among the correct responses was 'potassium hydroxide is included as a control so as to absorb carbon dioxide'.

In Part (c) (iv), candidates once again demonstrated their inability to correctly state an appropriate aim of an investigation.

### Question 3

This question tested candidates' knowledge of data recording and presentation and their ability to read graphs and interpret data. Candidates generally performed creditably on this question with a reasonable number of candidates scoring at the top of the mark range.

Part (a) of the question required candidates to group the given heights of thirty students in a class in a frequency table. Most candidates were able to do this although too many made errors in counts.

Part (b) required candidates to construct a histogram of the data collated in Part (a). Candidates were often able to gain full marks on this part of the question. However, there is a still misconception about the use of histograms and bar charts/graphs. It should be noted that histograms are used for continuous data, for example the heights of individuals in a group, while bar charts are used for discontinuous data, for example the various species that occupy a habitat.

For Part (c) of the question, where candidates were required to describe the nature and shape of the distribution of the data shown in the histogram, performance was weak. This underscores the difficulties candidates generally seem to have analysing and interpreting data even when the data are well presented. Candidates were expected to note that the histogram showed few students of the class at the extreme groupings/the majority of students were in the 135cm to 139cm group/the average height of the class was between 130cm and 139cm/or similar type information.

Part (d) required candidates to give some advantages of using tables and histograms to show distribution of height data. This part of the question was not well done since the advantages relate to the importance of the ORR skills candidates are required to demonstrate. Tables and histograms give visual acuity; help to make the data meaningful, histograms specifically offer an easy way of making comparison and give the whole picture; tables in particular provide details not readily known from histograms, among other reasons.



**CARIBBEAN EXAMINATION COUNCIL**

**REPORT ON CANDIDATES' WORK IN THE SECONDARY EDUCATION  
CERTIFICATE EXAMINATION  
JANUARY 2007**

**BIOLOGY**

# BIOLOGY

JANUARY 2007

## Introduction

As customary the January 2007 sitting of the CXC examination in Biology consisted of four papers:

Paper 01	–	Multiple Choice
Paper 02	–	Structured Essay Questions
Paper 03	–	Extended Essay
Paper 042	–	Alternative to the School-Based Assessment

Performance of candidates in this examination showed some improvement over the performance in previous sittings of the January examination. Nonetheless, candidates must be mindful of the comments and suggestions offered by the Examining Committee to ensure continuing improvement in their performance, since a relatively large component of the candidate population make fundamental errors that prevent them from demonstrating their best efforts.

- Candidates must improve their test-taking skills. This includes practice in reading questions carefully and planning responses so that answers are organized in a logical and cohesive manner
- Candidates continue to waste a lot of valuable time providing irrelevant information in the essays. They should focus on key words such as ‘describe’ and ‘explain’ when reading the questions and be guided by the mark allocation and quantitative descriptors within the text of the question as far as possible.
- There was also the question of choice of terminology and descriptions provided. Familiarity with biological jargon allows candidates the opportunity to express themselves more accurately and reduces errors caused by over simplification.
- Candidates should pay more attention to the stimulus material provided in the questions, especially in Paper 02. The stimulus material is meant to guide the candidate to the expected responses. Too often candidates responded by providing obscure information on the topic that did not relate to the scenario presented.
- More emphasis should be placed on practical skills and the candidates’ ability to demonstrate these skills in responding to questions on the Alternative to SBA paper. Too many candidates seemed unfamiliar with basic laboratory equipment and material and even the simplest of biological/scientific methods. Candidates demonstrated particular weakness in identifying precautions and limitations of an experiment, as well as in stating aims and formulating hypotheses.

## PAPER 01 – Multiple Choice

Paper 01, consisted of 60 multiple-choice items. Performance on this paper was similar to that of 2006. Some of the topics that *continued to be* problematic for candidates were:

- Aspects of ecology including feeding relationships and food chains
- Role of enzymes in living cells
- Excretion in plants
- Aspects of growth in plants and animals, for example, role of auxins
- Aspects of nutrition
- The eye as a receptor and effector organ

## PAPER 02 – Structured Essay Questions

Paper 02 consisted of five short-answer structured questions of which the first was the data analysis question worth 30 marks. This paper tested all profile skill areas identified in the Biology syllabus. Candidate performance on this paper was better than in previous years as indicated by the fact that candidates gave a reasonable performance on all questions. There were no modes of zero, 1 or 2.

Candidates were able to attain marks across the allotted range for all questions, so it is evident that all marks on the paper were available. However, for more candidates to give their best performance, attention must be paid to observations and suggestions the Biology examiners have repeatedly noted. In particular, candidates' attention should be drawn to the use of the stimulus material in responding to the questions and the guidance provided by the spaces allotted to each question – answers should relate to the stimulus material and should be kept within the allotted spaces. Candidates must note that they are not required to repeat the questions to begin their responses.

### Question 1

This question dealt with some practical aspects of growth of seedlings, including ways of representing data, reading graphical data, describing the relationship shown on the graph and method of obtaining the data presented. Candidates were also required to display their knowledge of factors that may affect the growth of seedlings. Candidate performance on this question was generally within expectations.

Part (a) (i) required candidates to construct a graph based on data provided on the changes in the height of a plant over a 36-day period. This was fairly well done, and most candidates were able to gain several of the marks allotted to this part of the question. However, some candidates inverted the axes, omitted the title of the graph, selected scales that were inappropriate and produced graphs that were too untidy. In Part (a) (ii), candidates were expected to estimate the height of the corn plant on selected dates using the graph that they constructed. While the majority of candidates were able to read their graphs, far too many gave inaccurate readings, even though the graphs were accurately constructed.

Part (b) asked candidates to describe the pattern of growth shown by the plant over the period. Candidates' descriptions did not often give a full account with the majority of candidates omitting *the initial slow growth period*. Their responses generally referred to the *period of rapid growth* and *the slow growth period before growth ceased*.

Part (c) asked candidates to (i) name the food source of the plant during the early growth stage and (ii), to give two uses of the food obtained by the corn plant during the first six days. This part was not very well done. Too many candidates seem unaware that the *seed*, in particular the *endosperm* of the corn, provides food for germination and that the food provided is used in *respiration to produce energy* and to *provide materials for growth/ tissue development*.

Part (d) of the question, which explored candidates' knowledge of experimental procedures, was generally not very well done. Part (d) (i) dealt with experimental skills related to determining dry mass in plants. This part of the question was quite poorly done. Very few candidates demonstrated understanding of how one might obtain the data on the growth of a plant using dry mass. Most candidates could deduce that they would need an oven for drying the plant material and a balance or scale for weighing. However, few candidates accurately mentioned in their method that the *plant material had to be dried in an oven at 100°C for a period of time, cooled and weighed*. Part (d) (ii) asked candidates to indicate one step to ensure the accuracy of the results. This part of the question was also not well done. Candidates were expected to refer to *weighing and drying the plant material until it reached a constant weight*. In Part (d) (iii), candidates were asked to suggest one disadvantage of this method of determining growth. Candidates were expected to offer such suggestions as: *plants destroyed, must use several plants and take the average, and error could increase*.

Part (e) of the question sought to examine candidates' knowledge of selected mineral elements and their effects on plant growth. Performance on this part of the question was poor, since this is a normally well-known part of the syllabus. In Part (e) (i), candidates were to indicate the effect of lack of nitrogen and magnesium on the growth of the plant. Candidates were expected to refer to: *slower growth, smaller plant size, stunted, yellow leaves*. In responding to Part (e) (ii) candidates were expected to indicate the specific roles of these minerals and thus indicate that *lack of nitrogen would reduce the plant's ability to make proteins hence reduce growth*, and the *lack of magnesium would reduce the ability of the plant to synthesizes chlorophyll and reduce ability to photosynthesise*.

Part (f) of the question examined aspects of germination. Part (f) (i) which asked about the changes that occur in the seed during germination was not very well done. Many candidates were quite unclear about the changes that take place during germination. Candidates were expected to refer to: *water absorbed, activation of enzymes, digestion of food stored in cotyledons/endosperm, increased respiration rate; protein synthesis*. In Part (f) (ii) which asked candidates to state two conditions other than water that are necessary for germination too many candidates included 'light' in their responses. This is an all too familiar and perpetual misconception. Candidates are to be reminded that the conditions for germination under normal circumstances are: *air/oxygen; suitable temperature/ warmth* apart from water.

## Question 2

This question tested candidates' knowledge of the major constituents of bones and the role and function of bones in the human body through information presented graphically. Candidates were required to interpret a bar graph showing the incidence of osteoporosis in males and females in a range of age groups. Performance on this question was generally good.

In Part (a), candidates were asked to draw two conclusions from the graphical data provided. This part was well done by most candidates. They were generally able to interpret the histogram by

stating that *osteoporosis was more common in women than men* and that it was *more prevalent in both men and women as they grew older*, in addition to a few other reasonable conclusions drawn from the graph.

Part (b), in which candidates' were required to apply their knowledge of biological principles associated with bones and their structure and development to understanding the disease of osteoporosis, was the most difficult part of the question for the majority of candidates. In Part (b) (i), candidates were asked account for the development of osteoporosis and in (b) (ii) to give two functions of oestrogen in light of the association of its levels with the incidence of the disease. Candidates were expected to include in their responses: *replacement of bone cells slows down, less nutrients are being utilized by the body, metabolism decreases, the body's large framework requires more nutrients for example, calcium* in response to Part (b) (i). In response to Part (b) (ii) candidates were expected to include: *development of female sex organs, female secondary sexual characteristics, menstruation and ovulation; helping to maintain the strength of the bones by helping to control loss of calcium from bone to blood.*

Part (c) examined candidates' knowledge of the effects of osteoporosis and means of reducing the incidence of the disease. This part of the question was reasonably well done. In Part (c) (i), they were asked about the likely effects of osteoporosis on the body and (ii) to suggest a mineral supplement for people with the disease. The majority of candidates mentioned weaker bones and the increased likelihood of breakage and misshapen bones. Other responses that rarely turned up included: *restricted movement, amount of red blood cells produced/ oxygen carrying capacity, poor protection of important organs.* Candidates generally suggested a calcium supplement in response to Part (c) (ii).

Part (d) (i) asked candidates about the value of bone as living tissue. This part of the question was not well done. Candidates were expected to suggest that because it is living tissues: *the bone can grow/increase in size; if damaged it can be repaired, provides a locus for synthesis of substances/ cell and reactions.* Far too many candidates were unable to give two functions of bone, apart from support. Candidates were expected to select their responses from: *make blood cells; protect important organs; enables movement/locomotion.*

### Question 3

This question assessed candidates' knowledge of the menstrual cycle in the human female, the role of hormones involved in the menstrual cycle as well as the role of the placenta during the development of the foetus. Candidates were also required to explore their knowledge of birth control methods. Generally candidates performed within the range of expectation. Candidates attained scores right across the range.

In Part (a) (i), candidates were required to label specific parts of the graph to indicate when certain events take place during the menstrual cycle. This part of the question proved quite challenging for candidates even though much leeway was given in placing the labels almost anywhere within a range of days. Again it is observed that candidates tend to be deficient in the specifics of their knowledge and provide many inaccuracies. On the other hand candidates were generally able to identify two hormones involved in the menstrual cycle and give the function of at least one of those hormones which was required in Part (a) (ii).

Some candidates focused on general functions of oestrogen and not those relevant to the menstrual cycle and few candidates seemed familiar with the role of progesterone. Candidates were expected to focus on: *oestrogen and its control of the repair of the uterine wall*, and on *progesterone for thickening and vascularisation of the uterine wall*. There was a lot of evidence of incorrect spelling of the names of the hormones.

Part (b) required candidates to indicate three functions of the placenta during the development of the foetus. This part of the question was very poorly done. Candidates displayed little knowledge of the function of the placenta. A good response would have included: *exchange of food materials (useful/waste)*; *exchange of gaseous material (oxygen/carbon dioxide)*; *physical barrier to pathogens/chemicals*; *allow separate functioning of the blood stream that protects mother and child*; *production of hormones important in pregnancy*.

Part (c) examined candidates' knowledge of birth control methods. In Part (c) (i) they were required to state three birth control methods used by humans. Candidates appeared quite knowledgeable about the methods, grouping them into types such as 'barrier', 'chemical'. However, far too many candidates seemed unable to spell the word '*abstinence*' and produced an extensive variation on the spelling. Again there is need to caution that the correct spelling of biological terms is a requirement of candidates. Part (c) (ii), in which candidates were to suggest why birth control seemed more important in humans than in other populations, was also well done. Candidates often mentioned the 'absence of a mating season', the 'brain gave an advantage in controlling human behaviour'. Additional responses on which candidates could have focused include: *humans manipulate their environment more*; *human population has risen sharply in the last centuries*; *advances in medicine*; *extended lifetime of humans*; *reduced mortality*; *more readily available food supply*.

#### Question 4

This question examined candidates' knowledge of the structure of plant and animal cells, differences in constituents in both cells and respective functions of cell organelles. Candidates were also asked about their knowledge of diffusion of materials into and out plant and animal cells. Candidates were generally familiar with the topics and gained marks across the spectrum from 1 - 18. A very few candidates were unable to gain any marks at all. The mean was about 8.5 out of a total of 18 marks and the mode was 5.

In Part (a) (i), candidates were required to label both diagrams provided to show the site of certain cellular functions common to both cell types, and in Part (a) (ii), labels were to indicate certain functions peculiar to the plant cell. This part of the question was only fairly well done. A relatively large number of candidates were unable to provide accurate labels in certain instances. In particular there remains the confusion between the terms 'cell membrane' and 'cell wall' and their respective differences. Candidates must note that the *cell wall is permeable* but the *cell membrane whether in plants or animals is selectively permeable* and be able to identify the relevant structures in diagrams.

Part (b) of the question was fairly well done. Candidates were initially required to identify the nucleus of the animal cell in Part (b) (i). They were then required in Part (b) (ii) to suggest one process that would be affected by the absence of the nucleus from the cell and to give a reason. Candidates were expected to include in their responses: *cell division since the chromosomes/nucleus controlled that process*. Note that *mitosis* was accepted as a satisfactory response.

Part (c) dealt with candidates' knowledge of the process of osmosis in plant and animal cells. This part of the question was fairly well done. In Part (c) (i), candidates were asked to predict the changes that would occur in the two types of cells if left in distilled water for a period of time. Candidates were generally able to deduce that *water would enter the cells and that the animal cell would swell and probably rupture, while the plant cell will become turgid but not burst*. Candidates were able to use their predictions in Part (c) (i) to respond to Part (c) (ii), which asked to explain the differences in the responses of the two types of cells. They generally indicated the role of the *cell wall in exerting pressure* preventing the plant cell from rupture when it takes in large amounts of water.

Part (d) of the question proved most challenging for the majority of candidates. Candidates were required to offer an explanation for why blood cells in the watery plasma medium did not absorb excessive amounts of water. Candidates generally did not realise that the cytoplasm of cells is itself a fluid medium containing solutes and therefore an osmotic gradient is maintained between the plasma and the cell contents. Candidates were thus expected to include in their explanation information that included aspects such as: *plasma contains solute; osmotic pressure/concentration of plasma high; red blood cells and plasma have similar concentrations; no net movement of water into and out of cell*.

Part (e) of the question also proved difficult for a majority of candidates. Candidates were required to offer an explanation for persons living at high altitudes having a larger number of red blood cells per unit volume of blood than a person living at sea level. Candidates were expected to apply their knowledge of the role of red blood cells in carrying oxygen and extrapolate that with a larger volume of red blood cells the oxygen-carrying capacity would increase. This would suggest less available atmospheric oxygen and the increased volume of red blood cells is a mechanism for ensuring the body has available its required supply of oxygen.

### Question 5

This question tested candidates' knowledge of the structure of the fish gill, the mammalian lung, effects of smoking on the lungs and the effects of water pollution on marine life. Performance on this question was reasonable. Candidates seemed to most easily access the marks in the parts of the question that dealt with the effects of smoking on the lungs and the effects of pollution on marine life

Part (a) (i) of the question asked candidates to suggest the function of gill rakers given the position in the diagram. Candidates did not generally seem familiar with this part of the gill but many were able to provide a reasonable response. Many candidates referred to the function as 'filter' but made reference to air and chemicals. The gill rakers, however, are for physical protection in that they trap solid particles and thus protect the delicate gill filaments. Part (a) (ii) asked candidates to indicate one feature of the gill filaments which they observed in the diagram and which allowed the filaments to function efficiently. Candidates were expected to refer to the *finely divided* nature of the filaments and the consequent increased *surface area*. Candidate performance on this part of the question was fair. Too many candidates referred to features like 'copious blood supply' which they could not deduce from their observations. Part (a) (iii) required candidates to give one other function of the filaments. Candidate performance on this part of the question was good. They were generally able to include in their responses: *thin cell membrane; copious blood supply; means of maintaining a diffusion gradient*.

Part (b) proved challenging for a majority of candidates. They were asked to relate the structures shown on the diagram of the gill to comparative structures in the human lungs in terms of common functions of the parts. Candidates were expected to relate such structures as: *filaments* with *alveoli*; *rakers* with *hairs/cilia*; *gill bar* with *cartilage/bronchi/ bronchioles*.

Part (c) required candidates to state three ways in which the lungs of a smoker may be affected by the smoking habit. This part of the question was fairly well done. Almost all candidates were able to give at least two ways in which smoking affected the lungs of a smoker. However there were a number of misconceptions such as ‘tobacco smoke may block bronchioles’; ‘the heart may become black – heart attack’; arteries and vein become blocked by tar’. Candidates were expected to refer to: *blackened/build up of tar*; *cancerous growth*; *damaged lining*; *reduced functional areas*.

Part (d) explored candidates’ knowledge of aspects of the impact of human activities on the environment. Candidates performed quite well on this part of the question. In Part (d) (i), candidates were asked to identify two human activities apart from smoking that contribute to pollution. Most candidates provided responses that ranged from using key words such as ‘smelter plants’ and ‘oil tankers’ to ‘improper sewage disposal’. Candidates’ responses were expected to fall under: *industrialisation/factory emissions/vehicle exhaust fumes*; *agricultural practices/pesticides, chemical fertilizers*; *improper waste disposal*. Candidates also performed well on Part (d) (ii) in which they were asked to identify two effects of polluted waterways on aquatic life. A surprisingly large number of candidates referred to concepts like ‘eutrophication’ and the general performance on this part of the question was very good. Candidates were expected to draw their responses as many of them did from these general concepts: *algal proliferation*; *disruption of food webs*; *loss of species*

### PAPER 03 – Extended Essay

Candidates’ performance on this paper was consistent with their performance in January 2006. Candidates demonstrated a continuing ability to write at length about biological events, principles and concepts. However, sometimes candidates missed key words in the questions and provided answers which were off the point. It is thus reiterated that candidates should be advised that *the reading time should be used to read through each question carefully, highlighting key words on which the questions hinge, so that they would be less likely to misread and misinterpret questions. The reading time should also be used to plan their responses so that they are more likely to stick to the relevant topics*. It is clear that much time is spent on teaching and learning the content of the syllabus. However, more attention needs to be paid to developing important examination techniques which will allow candidates to make the best use of what they know.

#### Question 1

Candidates selected this question more frequently than they selected its counterpart in SECTION A of the paper. This question dealt with aspects of conditions in and of the alimentary canal, the value of healthy lifestyles and balanced diet, and the effects of reducing the size of the stomach through surgery. Candidates gave a fair performance on this. However, candidates’ scores ranged from 0 to 16, thus candidates were not accessing full marks on this question.



In Part (a) (i), candidates were required to explain how different pH levels are produced along the length of the alimentary canal and in (a) (ii) to offer reasons for the elongated tubular structure of the alimentary canal. Candidates generally knew that the pH changed along the length of the alimentary canal and that these changes related to secretions produced at different points along the alimentary canal. However, most candidates focused only on the stomach and the small intestines. Candidates were thus expected to include in their responses some of these ideas: *different substances produced along the alimentary canal alter the pH levels; mouth – saliva, neutral to alkaline; stomach – HCl lowers pH; duodenum – bile – neutralizes acid/raises pH; small intestines/large intestines – neutralizing effects of bile; intestinal juices – alkaline to neutral*. In responding to Part (a) (ii), candidates often gave reasons associated with absorption and not digestion of food as the question required. Their responses were expected to include: *large surface area to volume; small volumes of food passed along at a time; increase exposure of food to enzymes/digestive juices; food takes time to move along; adequate time for digestion to occur; increases chances of contact with enzymes/digestive juices; greater access for glands and their secretions*.

Part (b) dealt with candidates' understanding of the relationship between healthy lifestyle and balanced diet and weight control in humans. Part (b) (i) asked to identify some constituents of a balanced diet and Part (b) (ii) asked to suggest the likely effects of age and lifestyle on the constituents of a balanced diet. Most candidates were able to gain the marks allotted to Part (b) (i) as they could identify at least four constituents of a balanced diet. A few candidates seemed not to know the meaning of the term 'constituent'. Candidates generally had some idea about the effects of age and lifestyle on the constituents of a balanced diet. However, poor expression and improper sequencing of ideas and thoughts sometimes resulted in a garbled account that could not be rewarded. Candidates must spend time and effort on organising their thoughts and ensuring that what is written is what they mean to convey. Fundamentally candidates need to convey that *a balanced diet had different constituents and the quantity of constituents required, vary according to age and lifestyle*. They also need to provide specific examples of changes to the diet that came about because of age and or lifestyle. Some candidates viewed a balanced diet as a fixed entity and held the misconception that the young needed a balanced diet and older persons did not. The following formed the major part of a good response:

Age and lifestyle have a great effect on the constituents of a balanced diet. As you get older you may have to increase your intake of some food groups. For example, people at a young age require extra amounts of proteins and carbohydrates since they are growing and cells need to be repaired and made constantly... As they get older, protein and carbohydrate intake should also be reduced due to the body not being able to function as efficiently ... since they become less active as they grow older ...

Part (c) examined whether candidates understood the implications of stomach stapling surgery in terms of risk and ability to control weight gain. In Part (c) (i), candidates were to explain why stomach stapling might be an option to control weight and in Part (c) (ii) they were required to give disadvantages of the stomach stapling procedure for individuals. Candidates performed fairly well on these parts of the question. They generally understood that if the volume of the stomach decreased food intake will decrease and this will have an effect on the weight of the individual. A good response to Part (c) (i) was as follows:

It is an important option because, if the volume of the stomach is reduced, the amount of food a person eats will also be reduced. This would mean that excess fat on the body will be used up and result in weight loss.

Part (c) (ii) was not as well addressed by candidates in that many candidates did not focus on the disadvantages which the question sought. Candidates were expected to compose their responses from ideas such as: *condition is temporary; life style changes also crucial; stomach can stretch; does not control quality of food; surgery dangerous/life threatening.*

## Question 2

Although not as popular as its counterpart question in SECTION A, candidates performed better on this question. The question required a brief explanation of how nitrogen is cycled through living systems, an account of human activities that disrupt natural cycles and relevant mitigation strategies and means of reducing the spread of contagious disease.

In Part (a) (i), candidates were asked to explain how nitrogen from the air is cycled through living systems and in (a) (ii) to suggest why the cycle was important. Although candidates were generally familiar with the Nitrogen cycle, this question proved rather difficult for them. Candidates seemed unable to manipulate the information they knew to give an appropriate response, thus few candidates obtained full marks for this question. In some cases they were confused about the order of the cycle, or they failed to place appropriate arrows on the diagrams or simply could not recall specific facts about the cycle. Grave misconceptions included: ‘root nodules of leguminous plants take up only nitrates’; ‘animals respire and produce nitrogen’. Further, candidates did not link the role of the nitrogen cycle with such concepts as: *allowing for the reuse of simple substance (elements and compounds); reducing chances of depletion; preventing accumulation of substances that might become toxic or would pollute the environment.* They, therefore, failed to gain marks allotted for the importance of natural cycles.

In Part (b), candidates were asked about the impact of human activities on natural cycles. In Part (b) (i), candidates were asked to identify human activities that disrupt natural cycles, and in (b) (ii), to describe precautions that can be taken to reduce the disruption of natural cycles. Part (b) of the question was generally well done. However, a number of candidates failed to gain marks on this part of the question because they provided examples of activities that disrupted the ecosystem generally or life cycles of organisms without making the link with the natural cycles as the question required. This further highlights the need for candidates to carefully read the question and highlight key words before attempting questions. A good response to Part (b) (ii) is as follows:

Deforestation disrupts the carbon cycle, the oxygen cycle and nitrogen cycle. This activity increases the amount of CO<sub>2</sub> in the air, reduces the O<sub>2</sub> in the air and may lead to soil erosion, which will reduce nitrates in the soil. Laws should be put in place to reduce the amount of trees removed. Reafforestation should be practised. Alternative materials could be used and paper could be recycled to reduce the need to cut down trees. These activities would maintain a stable cycle.

Part (c) examined candidates’ knowledge of how human activities can minimize the spread of diseases. In Part (c) (i) they were asked to identify two diseases that occur because of inappropriate hygiene and lifestyle human practices. This question was well done by most candidates. The majority of candidates were also able to explain how proper hygiene and sound lifestyle practices can reduce the occurrence of identified diseases. However, candidates had great difficulty spelling the names of diseases, and sometimes were unable to distinguish between a symptom of a disease and the disease itself.

### Question 3

The question tested candidates' knowledge of the structure and roles of red and white blood cells in humans, sanitary practices related to wounds, the role and effectiveness of antibiotics, aspects of immunity in humans and ways of preventing some viral diseases. This was the more popular of the pair of questions in SECTION B of the paper. Candidate performance on this question was satisfactory.

Part (a) asked candidates to (i) distinguish between the structure of mature red and white blood cells and (ii) explain the likely effects of having a relatively low red blood count. Most candidates scored well on Part (a) (i) especially when they used a tabular format in their response. But as with every other question candidates often did not read the question carefully enough and gave the differences in function not required in this section of the question. Some candidates gave diagrams of the cells but failed to label them and thus could not be awarded marks. While candidates generally recognised the red blood cells as constituted mainly of haemoglobin, some described them as having **more** haemoglobin than white blood cells and lost the relevant marks. In responding to Part (a) (ii), candidates generally mentioned less oxygen to tissues, therefore tiredness resulted. However, some candidates, possibly misreading the question, stated factors that could contribute to a low red blood cell count instead.

Part (b) of the question explored candidates' understanding of (i) the blood clotting process and some practices associated with the prevention of bleeding, and (ii) practices associated with the taking of antibiotics. Candidates performed well on Part (b) (i) of this question suggesting wide ranging and reasonable responses for wrapping the wound to stop the flow of blood, including less pain and the need for the action in case he was a haemophiliac. In response to Part (b) (ii) more than half the candidates felt that the body's own immune system should be allowed to work rather than be compromised by an unnecessary course of antibiotics.

In Part (c), candidates were asked to (i) identify two types of immunity, and (ii) offer suggestions about the benefits of encouraging pregnant women to be tested for the HIV/AIDS virus. Candidate performance on this part of the question was fair. Part (c) (i) was not at all well done. There were numerous misconceptions about the types of immunity and the ways in which immunity caused protection. Candidates were expected to include in their responses about *natural immunity* the following: *white blood cells produce antibody in response to antigen; memory cells activated on subsequent invasion by antigen; creates protection from similar/same pathogen; antibodies pass from mother to baby via placenta and breast milk; newborn is immune*. In addressing *artificial immunity* they were expected to include: – *vaccinations/inoculations; stimulate production of target antibodies; body's defense system improved/prepared*. Part (c) (ii) was generally better done as candidates included responses such as: *reducing the likelihood of the spread of the disease; infected mothers can pass on the disease to babies; newborns can be treated*.

### Question 4

By far the less popular of the question pair in SECTION B, this question required knowledge of receptors and effectors, the coordinating role of the Central Nervous Systems, and the roles of muscles and appendicular skeletal apparatus in locomotion. Performance on this question was satisfactory.

Part (a) asked candidates to distinguish between receptors and effectors with the use of examples. This part of the question was fairly well done. The majority of candidates were at least able to provide examples of effectors and receptors even if they could not provide accurate definitions of the terms.

Part (b) sought to explore candidates' knowledge and understanding of reflex actions. In Part (b) (i), candidates had to explain how the eye and the central nervous system work to respond to a crisis. Better performing candidates readily obtained marks on this question as they recognised the eye as containing receptors that sent stimuli to the brain for interpretation and response. Candidates were expected to draw their responses from the following: *light rays refracted from dog; light rays enter through pupil/pupils adjusted; rays pass through lens and other structures; retina/rods and cones stimulated; sensory neurons take message to the brain; via optic nerve; message interpreted by brain; girl distinguishes dog/dog's ferocity.* In Part (b) (ii) in which candidates were to explain the changes that take place in the body as a result of adrenalin production, performance was only fair. Candidates generally did not give a comprehensive enough account of the role of adrenalin. They simply referred to 'the heart beats faster' and 'more blood flows to parts of the body'. Candidates were expected to include in their description a coherent account around: *heart-beat increases; more blood flows to muscles in leg/necessary organs; more oxygen supplied to muscles and brain; more energy released; decides on flight.*

Part (c) asked candidates to (i) describe how the movement of muscle and bone occur to raise the leg, and (ii) explain why the leg becomes tired and what occurs when the leg is at rest. Part (c) (i) was the least well done part of this question. Candidates generally did not seem to understand how muscles and bones work together to bring about movement of a leg and several misconceptions were evident. Many candidates referred to muscles in the legs as biceps and triceps. They were not sure which muscle raised the knee when it contracted, and there seemed to be little conception of antagonistic muscles. Candidates also did not know the difference between ligaments and tendons. Quite a few candidates referred to the knee joint as 'a ball-and-socket joint'. Not one candidate mentioned that the upper thigh muscle was connected to the tibia and fibula across the knee joint. Candidates were expected to include in their responses the following in responding to this part of the question: *antagonistic muscles function; flexor pulls leg upwards causing bending at knee; extensor extend leg forwards; hinge joint allows movement in one plane only; lifting of leg and extension action repeated; ligaments at knees hold joint in place.* On the other hand Part (c) (ii) was very well done. Candidates were generally aware of what caused the leg to become fatigued. They included in their responses 'the lack of oxygen leads to anaerobic respiration which resulted in the formation of lactic acid'. They were also aware that 'oxygen debt developed and this was being repaid when the leg was at rest'.

### Question 5

This was the less popular question of the pair in SECTION C. The question dealt with the ways in which xylem is suited to its function and agricultural practices that related to the biology of plants/seedlings such as watering of plants; covering transplanted seedlings and thinning of crops. Candidates under-performed on this question. Candidates had great difficulty accessing marks in the upper ranges with no candidates scoring more than 15 marks.

In Part (a) of the question candidates were required to describe ways in which the xylem is suited to its function. Candidate performance on this part of the question was poor. They showed a general lack of knowledge of the structure of the xylem and too often confused xylem with phloem. In many cases the diagrams did not focus on structural features that facilitated the passage of water in the stem. Candidates were expected to include in their responses: *empty lumen for free flow of water; walls join end to end to cover long distances up the stem; no end walls which increases the length of the xylem tube; thick wall/lignified for support/strength.*

Part (b) asked candidates to provide explanations for certain agricultural practices. Candidates were able to provide reasonable explanations for some of the practices identified, but they did not usually use terms expected of biology students writing a Biology examination. However, their greatest challenge was in providing a rationale for supplying plants with too much water. Surprisingly, many candidates referred to plant cells as though they were animal cells and made such inaccurate statements as ‘too much water will cause cells to swell and burst’ or ‘plants will drown’ or the plants themselves become ‘water logged’. Responses were expected to show that the excess water in the soil reduces the capacity of roots to breathe and/or may actually cause the root to decay. The consequences to the plant would be inevitable. Concepts contained in the following were thus expected to be included in the responses: *soil may become waterlogged; less air available to the roots; roots are not able to absorb water; roots are not able to absorb minerals; roots will die.* In (b) (ii) in which candidates had to offer an explanation for farmers covering newly transplanted seedlings, candidate performance was reasonably good. However, candidates generally referred to protection from drying conditions of the atmosphere or from direct sunlight. Few candidates referred to water relations that was the trend of the question. Candidates were expected to consider that *newly transplanted seedlings are not able to take up water efficiently; seedlings may wilt; roots may be damaged; roots are not established so rate of water uptake is slow; seedlings not ready for full exposure to sunlight.* Part (b) (iii) asked candidates to explain why some healthy seedlings may be removed several weeks after transplanting while other plants are left to grow. Candidates performed reasonably well on this question, although many candidates assumed that the seedlings left behind were weak. Generally, they understood the concept of competition for nutrients, water, light and space. However, they still use the term ‘nutrient’ and ‘food’ interchangeably which should be avoided. Some candidates need to develop their responses to give complete explanations as illustrated in the following guidelines: *reduces overcrowding; competition for light/prevents photosynthesis; competition for water/less transpiration, plants may wilt; competition for nutrients/affects growth and development; competition for space/affects growth and development.*

### Question 6

This question required knowledge of relationships between the trophic levels in a named habitat, the advantages and disadvantages of rearing fish in an aquarium, moving fish from one type of environment for breeding into a different environment and the effect of water pollution. This was by far the more popular question of the pair in SECTION C. Candidate performance on this question was fair with a mean of 6.9 and a mode of 6. Candidates found the biomass diagram and questions about pollution by oil spills to be the easiest parts. They had the greatest challenge in explaining why fish cannot be repatriated from a salt water to a freshwater environment.

Part (a) required candidates to draw a biomass pyramid and describe the relationships between trophic levels in a named habitat. Most candidates were able to draw the biomass pyramid relevant to a specific habitat, but describing the relationship between trophic levels was not well done. Candidates were expected to include in their description specifics about producer and consumers, the relative numbers of successive levels of the pyramid and the movement of energy through the levels to include the following concepts: *producers make food from simple compounds; primary consumers feed on producers; secondary consumers on primary producers; successive levels have lower biomass; producers convert light energy to chemical energy; energy becomes available to subsequent levels; energy used up at each level.*

In Part (b) (i), candidates were required to suggest advantages and disadvantages of rearing fish in an aquarium. Candidates provided clever responses to the advantages, but their conceptions were limited to small aquaria found in homes and not large aquaria as may be found in museums. Their answers included: ‘the fish will be in a tight, confined area, with not much movement’; ‘overcrowding’. Candidates were expected to frame their responses from the effects on the fish, but many candidates commented solely from the human perspective. Candidates could have drawn their responses about **advantages** from: *aesthetics; not required to search for food; protected from predators*, and about **disadvantages** from: *dependent on humans for survival; recycling of nutrients limited; lose role in food chain; mating difficult*. In Part (b) (ii), candidates were asked to explain why a marine fish should not be bred in freshwater ponds. This part of the question was very poorly done. Candidates considered factors such as ‘proper care of the fish’, ‘cost of maintaining the aquarium’, ‘mutation’, ‘what the fish would enjoy’ rather than the physiology of the fish which would have been the fundamental problem of breeding the fish in freshwater. Candidates were expected to indicate ideas such as: *body fluids of marine fish different from freshwater fish; osmosis will occur; excessive water likely to enter fish; inability to cope with excessive intake of water; fish could swell and die; the kidney would have to excrete water continuously.*

Part (c) required candidates to suggest how oil spills might affect marine organisms. This was a known part of the syllabus and candidates generally gave reasonably good responses to this question. They recognised that the spilled oil will reduce the amount of oxygen available to marine organisms. Candidates were expected to include in their responses: *prevents oxygen from dissolving; less oxygen available to living organisms; affect the breathing apparatus of organisms; kills organisms; disrupts food chain/webs; immobilises birds/fish/other marine species.*

### **PAPER 042 – Alternative to the SBA**

This paper assessed all the practical skills required of biology students. It is quite clear that too many candidates are unfamiliar with biological techniques and methods. Candidates continue to display weak practical skills especially in planning and designing, manipulating and describing methods of experiments and in drawing conclusions from data. These observations suggest that teaching for developing practical skills must include actual experimenting and investigating scientific phenomena, discussions, explanations and rationalizing of procedures and outcomes on the part of students so that they become capable of developing and manipulating experiments and experimental data on their own.

## Question 1

This question tested a range of candidates' experimental skills including observation, means of recording data and representing findings, as well as their knowledge of aspects of quantitative ecology. Some candidates displayed weak skills in drawing graphs and constructing appropriate tables. While most candidates were familiar with quadrats as a tool for collecting field data, the majority of them did not know how such data was used in estimating species distribution.

Candidates were required to demonstrate practical skills of Observing/Recording/ Reporting, Measuring, and aspects of Planning and Designing. In Part (a) of the question, candidates were required to construct a table using information presented in a diagram. This part of the question was fairly well done with most candidates securing some marks. However, far too many candidates failed to follow the conventions for table headings and columns and provided no title for the table. Also, some candidates made careless errors in the counts of the species and lost easy marks.

In Part (b), candidates were asked to calculate the density of one of the plant species. This was a poorly done question as the majority of candidates did not know how to compute the density of a species from data obtained using quadrats. The computation of density is based on the sum of the number of plants per quadrat throw for all throws divided by the number of quadrats/throws.

Far too many candidates were unfamiliar with the use of a quadrat and therefore could not appropriately respond to Part (c) which asked to describe how the quadrat was used to obtain the data. Candidates were expected to include: *throw randomly, count the number of each plant species/ quadrat; record, repeat/five times.*

Part (d) required candidates to explain how the data collected using the quadrat could be used to determine the distribution of the plants on the entire lawn. This was a poorly done question with most candidates not recognizing that they need to calculate the area of the entire lawn to be used along with the knowledge of the area of each quadrat and the density of the species.

Part (e) asked whether the quadrat could be used to estimate the distribution of animals. Candidates were rewarded for both positive and negative responses with appropriate explanations. Many candidates made reference to the large size of animals in support of a negative response. Candidates were also expected to support a positive response for slow moving animals and a negative response in support of the fact that animals generally move from one place to another.

Part (f) asked candidates to represent data on animals on graph paper provided. This question was not well done by candidates since the majority used a histogram instead of a bar chart which is an appropriate choice for discrete data. Further, many candidates did not provide titles for the graph nor did they label the axes appropriately. Sometimes they chose inappropriate axes.

Part (g) asked candidates to describe two means other than the bar chart for representing the data collected on the animal species. Many candidates selected a line graph as one of the options which again suggests some lack of understanding of appropriateness of methods for representing the data. Thus, this part of the question was not well done. The responses to both Parts (f) and (g) indicate that more attention must be paid by candidates to the conventions for graphs, tables and other means of representing biological data.

## Question 2

Apart from aspects of planning and designing, such as determining the aim of the investigation and identifying precautions this question tested the candidates' ability to carry out a simple investigation which required them to use their observation skills in the context of their knowledge of experimental procedure. Candidate performance on this question was weaker than anticipated. Candidates generally assume that heat is visible and the fogging of the mirror was due to heat, and they did not recognize the mirror as the control of the investigation. This calls into question their understanding of experimental control generally. Candidates also found difficulty with the experiment to determine whether exhaled air contained carbon dioxide and several questions related to this part of the question were not very well done.

In Part (a) (i), candidates were expected to breathe on a mirror and make observations about changes on the mirror. Most candidates were able to describe the changes using acceptable terminology. In Part (a) (ii), they were to describe a test to identify the substance on the mirror. This part was very badly done. Most candidates seem unfamiliar with cobalt chloride paper which goes from blue to pink in the presence of moisture, or anhydrous copper sulphate which turns blue. Also poorly done was Part (iii) which asked candidates to draw a conclusion based on their observations of the mirror when breathed upon. Most candidates failed to draw a conclusion that indicated that *exhaled air contained moisture*. Most candidates felt that the condensation on the mirror was 'heat' not realising that it was moisture that condensed because of temperature changes. Very few candidates recognised that the control was *the mirror before being used*. Most indicated that there was no control in the investigation. Good responses were:

Yes, the mirror before the investigation is exposed to air that is not exhaled and therefore has the same conditions with only that variable changed. Therefore, it can be considered a control at that point. OR

Yes it does because you can see that there is no moisture on the surface before.

Part (b) of the question dealt with an investigation into difference between inhaled and exhaled air. In Parts (b) (i) and (ii) respectively, candidates had to provide a label for the substance through which the air passes before being inhaled, and to insert arrows on the diagram to show the direction of flow of air in the investigation. These parts were generally badly done and show that the majority of candidates were quite unfamiliar with basic biological experiments and experimental procedures. For example, candidates did not appreciate that the air is first passed through lime water to remove carbon dioxide from the inhaled air to show that carbon dioxide from the body is found in exhaled air. Part (b) (iii), which asked for an aim for the investigation, was only fairly well done. Candidates were expected to include in their aim reference to the constituents of inhaled and exhaled air.

In Part (b) (iv), candidates were asked to state two precautions to be taken in setting up the investigation. This part of the question was fairly well done in that candidates generally referred to keeping the apparatus airtight. Candidates could have selected from: *apparatus must be airtight; levels of indicator must be the same in both tubes; use an accurate measuring device*. In Part (b) (v), which required candidates to predict the changes that would occur after two seconds and after 30 seconds, was also not quite well done. Candidates were expected to indicate that *no change* would occur after two seconds and the *lime water would go milky* in 30 seconds.



Part (b) (vi) asked how holding the breath for one minute before exhaling might affect the results of the investigation. A relatively large number of candidates recognised that holding the breath would increase the volume of carbon dioxide in the lung thus increasing the rate of change of the limewater when exhaled because there is more carbon dioxide is present. Part (b) (vii) asked candidates to write the instructions on how to use the apparatus. This part of the question was fairly well done. Marks were awarded for *describing the steps in reasonable sequence; use of instruction mode, inclusion of precautions.*

### Question 3

This question tested the candidates' ability to draw their own front teeth as seen in a mirror, describe their observations about incisors and compare incisors with other mammalian teeth. Candidate performance on this question was a little below expectation.

Part (i) of the question required candidates to draw their incisors as seen in the mirror. Some candidates produced excellent drawings, but far too many tried to provide artistic rather than biological specimens and many candidates failed to observe biological drawing conventions.

Some of the errors made against conventions for biological drawings are itemised hereunder:

- Use of pencils that were too soft so that it was not possible to draw clean, clear lines
- Inaccurate representation of numbers of all components. Some candidates drew one tooth and did not indicate view or whether located in the upper or lower jaw
- Many omitted title and where the title was included this was not comprehensive or clear
- Inability to correctly state the magnification of the drawing. Errors related to magnification included the use of units such as 'cm'; indicating 0 magnification for a drawing of same size as the specimen; not writing the magnification correctly, for example, "x1" or "x1.5".

Part (ii) required candidates to identify the features of the incisor observed in the mirror. This was quite badly done as a description was expected that included: *white surface of tooth; flat/chiseled edges; crown/main part of tooth; smooth.* For Part (iii), candidates were required to give two differences observed between the incisor and any other two types of teeth. Although some candidates were able to gain full marks here, far too many were not able to describe differences that they could actually see. Candidates were expected to note that compared to the chisel-shaped incisors the *canines were sharp and pointed; premolars/molars were bigger with rough upper surfaces, large crowns.* In Part (iv), candidates had to indicate how differences observed helped in choosing the diet. This part was not well done. Candidates were expected to show how the varied dentition allowed for a varied diet, that is: *can eat a variety of food; incisors help to cut/bite leafy foods/vegetables/meat; canines tear flesh from bone; molars/premolars grind all types of foods.* A good response was:

Because of the type of teeth I have I can eat almost anything. I can tear pieces of meat with my canine, I bite meat, fruit, pastries anything with my incisors and also crush large pieces of food with my molar/premolars.

These differences allow me to eat a larger variety of foods than herbivores and carnivorous animals. Humans have various types of teeth allowing us to eat both meat and herbs.

**C A R I B B E A N   E X A M I N A T I O N S   C O U N C I L**

**REPORT ON CANDIDATES' WORK IN THE  
CARIBBEAN SECONDARY EDUCATION CERTIFICATE EXAMINATION  
MAY/JUNE 2007**

**BIOLOGY**

## BIOLOGY

MAY/JUNE 2007

### GENERAL COMMENTS

The June 2007 examination in Biology at the General Proficiency level was the 32<sup>nd</sup> sitting of this subject conducted by CXC. Biology continues to be offered at both the January and June sittings of the examinations. The biology examination is one of the more popular of the single sciences offered by the CXC at the CSEC level and assessed the performance of approximately 14 000 candidates this year. The examination comprises four papers: Paper 01 – Multiple Choice; Paper 02 – Structured essay paper; Paper 03 – Extended essay paper and Paper 04, the School-Based Assessment (SBA).

The overall performance of candidates this year was generally similar to that of last year's. Candidates were able to score across the range of marks for almost all questions. However, far too many demonstrated limited knowledge of fundamental biological concepts and principles and basic knowledge of biological phenomena. There is insufficient attention paid to several suggestions which the Biology examiners have repeatedly made over the past years, and candidates are still unable to adequately display the skills they are supposed to acquire in pursuing practical work. With the proposed changes to the form of the Biology examination, particular attention should be paid to these comments in preparing candidates, *if the desired improvement in performance is to be realized and sustained*. These comments relate both to test-taking techniques and means of addressing the content of questions, and are as follows:

- Teachers should remind their students that there is more to taking an examination than memorizing the content. When preparing students for an examination time should be spent practising *how to interpret* and answer questions clearly, concisely and to the point.
- Candidates also waste time providing information that is irrelevant to the question. This gains them no marks. This is particularly important for Paper 03. Candidates ought to make better use of the time allotted for reading through the paper, selecting their questions and planning their responses *before* starting to write.
- Too many candidates still do not read questions well. They should be advised to take special note of the cues given in the questions and underline key words to draw attention to what the question requires. When the question asks for two items many candidates give one and lose marks unnecessarily through apparent carelessness.
- Also, many candidates have the tendency to select an obscure partially correct response instead of the obvious more familiar response to questions. This relates to both question writing technique and knowledge of the subject matter. It should be noted that more marks are awarded for the obvious responses to the questions.
- In papers where limited spaces are provided for short answers, candidates insist on repeating the questions asked, leaving insufficient room for responses and then writing their responses in the margins. This wastes valuable writing time.
- Candidates should also use the question numbering as a guide to link the different parts of the question. They should note that the numbering changes when there is a change in concept or context. They should also make every attempt to use the information given in the various parts of a question to help focus the context and content of their responses.

- Biological jargon should be used where appropriate and spelling of biological terms must be correct. Spelling of common biological terms continues to be atrocious. It is not possible to award marks for incorrectly spelt terms where they actually mean something different. Candidates far too often seemed unfamiliar with common terms used in Biology, for example, “distinguish”, “precaution”, “factor” “implications” or “types”. Teachers should direct their students to the glossary of terms available in the CSEC syllabus.

Candidates’ general approach to responding to questions is to supply minute, and very often inaccurate details, at the expense of demonstrating understanding of fundamental biological principles and concepts. This is particularly noticeable in responses to questions on Paper 03. Candidates are expected to demonstrate understanding of fundamental principles and concepts such as *the relationship of structure to function; the relationship of living organisms to their environment; the cell as the fundamental unit of living organisms; genetics and variation and their role in perpetuating species, and the impact of disease on living organisms including social and economic effects on humans*. The Biology Team suggests that teachers should use more constructivist approaches in the teaching of Biology in which their students would be more involved in explaining their notions, clarifying the content and be more fully engaged in problem solving activities.

A disturbing trend in candidate responses to various questions was the allocation to plants of anthropomorphic characteristics, for example, plants were described as not having brains, feelings or the ability to respond to a punch like humans. This trend underscores the limited used of appropriate biological jargon and understanding of fundamental biological concepts.

There was also the problem of the lack of familiarity and use of appropriate biological terminology, which clearly affected candidate understanding of questions. Some examples include:

- Annotation
- Implication
- Factor
- Cause
- Greenhouse ‘gases’ versus ‘greenhouse’ effect
- Menstruation
- Stimulus
- Response
- Label

## **DETAILED COMMENTS**

### **Paper 01 – Multiple Choice**

Paper 01, as is customary, consisted of 60 multiple-choice items. Performance on this paper was slightly better than that of last year's. The mean for the paper was 62% compared with 60% last year.

Some of the topics that were most problematic for candidates were:

- Characteristics of insects in comparison to other arthropods
- Structure and function of red blood cells
- Cross-pollination as distinct from self pollination
- Identifying variables in an investigation
- Phloem structure
- Reflex arc and reflex action
- Aspects of growth in plants and animals, for example, role of auxins
- Role of insulin as opposed to adrenalin
- Human response to natural disasters
- Metabolic rate and effect on the body temperature
- Stages in the life cycle of an insect – egg, larva, pupa, adult
- Control of insect populations based on knowledge of their life cycles
- Distinction between population and community

### **Paper 02 – Structured Questions**

Paper 02 consisted of five short-answer structured questions of which the first was the data analysis question worth 30 marks. This paper tested all profile skill areas identified in the Biology syllabus. Candidate performance on this paper was below expectation given the nature of the questions and compared to the performance in the previous year.

Candidates were able to attain marks across the allotted range for all questions, so it is evident that all marks on the paper were accessible. However, for more candidates to give their best performance attention must be paid to observations and suggestions the Biology examiners have repeatedly noted. Observations and suggestions relate primarily to examination techniques which candidates should follow when writing this paper. In particular, candidate attention is drawn to the use of the stimulus material in responding to the questions and the guidance provided by the spaces allotted to each question. Candidates must note that they are not required to repeat the questions to begin their responses. Candidates also continue to display weak practical skills especially in planning and designing, manipulating and describing methods of experiments and in drawing conclusions from data. These observations suggest that teaching for developing practical skills must include discussions, explanations and rationalizing of procedures and outcomes on the part of students so that they become capable of developing and manipulating experiments and experimental data on their own. Simply having students write up experiments without orally communicating what they are doing and providing appropriate explanations for occurrences squanders the opportunity practical exercises provide for teaching and learning.

### Question 1

This question dealt with aspects of nutrition in green plants and animals, including ways of representing data and relationships among organisms. Candidates were also required to demonstrate planning and designing skills, as well as data collection strategies and their ability to interpret data. Candidate performance on this question mirrored that of last year's. Most sections of the question were well handled by the candidates. Candidates' weakest area was in providing a suitable aim for the investigation of photosynthesis. Candidates' responses to this question show the need for more exposure to the scientific method in all its aspects, including generating aims from hypotheses in their investigations.

Part (a) of the question required candidates' to demonstrate skill in planning and designing an investigation of the rate of photosynthesis under differing light intensities, provide an aim for the investigation and identify a precaution. Candidates were generally able to identify appropriate apparatus, but few were able to provide an adequate description of a suitable method which was required in Part (a) (i). Candidates were expected to describe how the leaves were to be prepared for the investigation, provide a description of the test to be used, including any data collection procedures, and means of determining whether the aim was achieved. Most candidates failed to gain marks for providing an appropriate aim which was required in Part (a) (ii) of the question. They generally repeated the hypothesis given. The aim was expected to relate to the test method and results, not simply a restating of the hypothesis. An appropriate aim provided by one candidate read as follows: *to determine if the leaves from different parts of the tree where light intensities differ contain the same amount of starch*. Most candidates were able to provide a suitable precaution that would have contributed to error in the results. One misconception observed in this part of the question was confusing *photosynthesis* with *transpiration* and candidates thus made reference to cobalt chloride paper in their experimental method.

In Part (b) candidates were required to draw a pair of graphs from data provided and identify from it the concentration at which carbon dioxide became a limiting factor. This part of the question was generally well done in that candidates knew how to select appropriate scales, correctly identify the x-axes and y-axes and plot the values which were required in Part (b) (i). However, many candidates provided incomplete titles, making no reference to the light intensities and some candidates still confused the axes. Note: *the controlled variable should be on the x-axis and the responding variable on the y-axis*. Part (b) (ii), in which candidates were asked to read aspects of the graph, was generally very well done. Candidate also performed well on Part (b) (iii) which asked for one other environmental factor that would affect photosynthesis. The expected response was *water*. However, weaker candidates sometimes indicated *temperature*.

Candidates performed quite well on Part (c) (i) of the question in which they were to indicate on a stylized diagram of a fruiting plant the direction of flow of food material by using arrows only, and on Part (c) (ii) which asked candidates to identify the transporting tissue. It is to be noted that many candidates could not spell 'phloem'.

Part (d) required candidates to interpret data presented in tabular form on the constituents of different types of milk. Part (d) (i) asked for reasons why breast milk is best for babies. Candidates were required to use the information in the table to provide the rationale. Most candidates were able to obtain at least half the marks for this part of the question because they made reference to nutrients that were in higher proportions. They were expected to zero in on the role of calcium for developing strong bones and teeth, the balance of nutrients for the baby's requirements and the amount of water and fat present. Many candidates saw the fat content as a means of insulation rather than as a means of providing energy which was quite odd given the presence of the fat in the diet and not under the skin of the baby. Part (d) (ii) which asked candidates to suggest one other value of breast milk was quite well done.

In Part (e), candidates were required to suggest two minerals used by plants and their respective functions. Many candidates were able to access all the marks allocated to this part of the question. However, a relatively large number of candidates who could identify the minerals could not state the functions. Some gave plant symptoms instead of functions of the minerals.

## Question 2

This question tested candidates' knowledge of parts of the appendicular (joints) and axial (vertebrae) skeletons in humans. The performance on this question was exceedingly poor given the basic requirements of the question. Very few candidates gained full marks and a significant number gained no marks at all. This was quite unexpected of biology candidates at this level. Further they generally displayed poor labelling techniques as if the conventions that apply to SBA no longer existed.

In Part (a), candidates were to answer questions about the elbow joint. In Part (a) (i), they were required to identify the type of joint. A fair number of candidates recognised that this was a *hinge* joint but far too many candidates mistook it for a 'ball and socket joint', and some used the global term 'synovial joint' which did not distinguish it from any other synovial joint. Most candidates found it difficult to correctly label the main parts of the joint which they were required to do in Part (a) (ii). They were expected to correctly identify the following features: *synovial membrane*, *synovial fluid*, *cartilage*, *capsule/ligament*, which are the parts of a typical synovial joint, as the elbow is. In Part (a) (iii), they were to suggest a function for the pad of fat illustrated in the diagram of the elbow joint. Only the better performing candidates tended to make an appropriate suggestion. The most common suggestions were for 'reducing friction', 'lubrication' or 'producing energy'. These responses were not awarded marks since the location of the pad of fat is more obviously appropriate for its function as a *shock absorber* or *cushion*. Candidates were also rewarded if they suggested *insulation*. In Part (a) (iv), candidates were asked to identify two parts of the joint that were likely to be worn away in arthritis sufferers. It appeared that since many candidates had difficulty labelling the joint correctly they also had great difficulty identifying the parts of the joint that were likely to be eroded after a time.

While several candidates gained full marks for Part (b) of the question which required them to compare two mammalian vertebrae, far too many candidates lost marks carelessly because they did not respond to the specific questions asked. In Part (b) (i), they were to name the two vertebrae and in Part (b) (ii), they were to name features in both that had similar functions, while in Part (b) (iii), they were to identify a distinguishing feature between the two vertebrae. Some candidates correctly identified the *lumbar* and *cervical* vertebrae illustrated, and also named features with similar functions such as the *neural spine*, *neural canal* and *centrum*. They were also able to indicate that the *relative size of the centrum*, *the transverse process and holes (vertebrarterial canals) in the transverse processes* were distinguishing features between the vertebrae. Candidates often misspelt the names of the vertebrae, and the features including the 'neural canal' and 'centrum'. It should be noted that where the words were not clearly discernible the candidates could not be rewarded. Spelling errors were prevalent. *Cartilage* was incorrectly spelt 'cartiledge' and 'cartage' among other misspellings, as was *synovial*, which was misspelt as 'cynovial' or 'sonovial', among others. Even a simple word as *hinge* was misspelt as 'inge', 'inch' or 'hindge'.

## Question 3

This question required candidates to display knowledge of the way the human eye operates in various light intensities, as well as the response by plants to external stimuli. Candidates performed creditably on this question.

Most candidates were able to correctly identify the stimuli for the responses illustrated in Part (a) (i). However, several candidates referred to the stimulus as 'shock' and a response to adrenalin. The question, however, referred specifically to an external stimulus. In Part (a) (ii), candidates were asked to describe how the response illustrated in Pupil II (picture of a constricted pupil) came about. This part of the question was fairly well done. Candidates were expected to refer to the pupil reflex in which: *light triggers the response action*, *the retina (cone/rods) detect the stimulus*; *circular muscles of the iris contract*; and *reflex action*. An excellent response was:

The light sensitive (photoreceptors) cells of the retina detect high light intensity and send electric signs to the brain via the optic nerve, which send a response via a motor neurone for the radial muscles of the iris to relax and circular muscles contract.

Part (a) (iii) asked candidates to explain the importance of the responses illustrated to humans. This part of the question was also fairly well done although some candidates tended to give vague responses. Candidates were expected to refer to specifics such as: *the protection of the retina; accommodation for seeing different light intensities or allowing for sight under differing light conditions*. Candidates generally made sweeping comments, for example: 'to see better'; 'better focus on objects' or 'to protect the eye'.

Part (b) of the question asked candidates to draw on diagrams presented to show how the eye functions under certain conditions. In Part (b) (i), they were to use arrows to show where the image would fall in a short-sighted individual. Although most candidates were able to gain at least one mark, many tended to place the image too far in front of the retina. Part (b) (ii) was fairly well done. Candidates were to draw a replacement lens to correct short-sightedness. However, some candidates failed to show a properly located concave lens and even drew the lens outside of the eye.

Part (c) of the question asked candidates to explain how the response by plants to external stimuli was different from that in humans. This part of the question was not well done by many candidates. Many candidates gave vague responses lacking the specific biological jargon. Further, they often did not give comparisons simply discussing either the plant or human response. Candidates were expected to indicate that *in plants the response was primarily a growth response; slow; limited to specific areas; irreversible*. A good response that gained full marks was:

Plant responses via auxins are very slow while humans may respond quickly to stimuli because of the nervous system; plants respond chemically by plant growth substances, auxins, while humans may respond chemically (hormones) and electrically (impulses).

#### Question 4

This question examined candidates' knowledge of the structure of fruit, seed dispersal mechanisms and certain aspects of reproduction in plants and humans. Performance on this question was rather disappointing given that many candidates were unable to obtain even the marks for labelling the fruit illustrated. Candidates often misread the question or misapplied their knowledge of the biology of fruits and seeds. For example, they described the adaptations of fruits for dispersal instead of adaptation of seeds asked in the question, or they did not label the fruit at all, which was also required.

In Part (a) (i), candidates were asked to label six parts of the section through the fruit illustrated. Candidates often ascribed arbitrary names to the parts of the fruit, for example, they called sepals 'leaves', epicarp was called 'skin' or 'exocarp', or receptacle was called 'stem'. In Part (a) (ii), candidates were asked to identify two adaptations of the seeds for dispersal by animals. Candidates were expected to focus on adaptations of the seeds in the stimulus material and not of seeds in general. Their responses were to focus on the *seed coat which cannot be readily digested; or the small size of seeds that would be able to pass through the human digestive system, or the protective jelly*. A large number of candidates referred to general characteristics of seeds dispersed by animals such as the 'presence of hooks to adhere to the coats of animals'. A number referred to adaptations of the fruit such as its 'bright colour', 'succulence' or 'scent'.

In Part (b), candidates were asked about dispersal of another type of fruit illustrated and to provide reasons why the figures shown in Parts (a) and (b) were described as fruit. Most candidates in response to Part (b) (i) incorrectly suggested that the fruit was dispersed by wind. They seemed unfamiliar with the *mechanical, explosive or self-dispersal* mechanism of dehiscent fruits. In Part (b) (ii), very few candidates scored full marks for this part of the question that asked them to explain why the illustrations were described by biologists as fruits. Candidates generally displayed little knowledge of the biological classification of fruits and the reasoning underpinning the classification. They instead referred to the 'Vitamin C content', 'food store for plant' and 'food for humans'. They were expected to refer to: *development from the ovary; that it contains seeds; and the presence of two scars – from attachments to the receptacle and style respectively*. The following responses gained full marks:



They have two scars, one from attachment to the plant and another where the style was attached; they have one or more seeds, which are the ovules after fertilisation.

These are classified as fruits since they both contain seeds, and because they have developed from fertilized ovaries of flowers.

Part (c) asked candidates for similarities and differences between the functions of ovaries in humans and in plants. This part of the question was not very well done. Many candidates' recognised that both ovaries played the role of producing gametes. However, few candidates were able to distinguish the differences in the roles played by the ovaries. They were expected to indicate that *in plants the ovary retained the gametes; the ova are fertilised in the ovary, or the ovary protects the embryo*. Acceptable responses were:

Similarity

They both produce gametes.

Contain female gamete for reproduction.

Differences

The ovary in humans produces hormone, progesterone and oestrogen, also it releases its eggs (ova) whereas the plant ovary keeps its eggs and does not produce hormones.

The ovary in humans plays a part in releasing the mature ova whereas the ovules in the plant are always in the ovary.

The ovary of the plant develops into a fruit, the ovary of the human is not part of the fertilized product.

One misconception observed in responses in this question was that fruits and seeds are the same, especially in the case of legumes.

Question 5

This question dealt with disease and their modes of transmission. The question also required knowledge of the incidence and spread of HIV and AIDS in the Caribbean. As anticipated, candidates performed rather well on this question, although it was clear that several candidates held misconceptions that need to be clarified.

Part (a) of the question asked candidates to complete a table with examples and causes of the major groups of diseases. This part of the question was fairly well done with most candidates gaining marks for at least identifying examples of the major categories of disease. Candidates were most familiar with deficiency diseases and their causes, although many candidates seemed to think that a deficiency disease meant lack of anything and not vitamins, for example, lack of insulin. Providing the causes for the other diseases was difficult for several candidates and they actually named the disease rather than the cause in some instances. The following response obtained full marks.

Type of disease	Example	Cause
Pathogenic	Malaria	Pathogen in Anopheles mosquitoes
Deficiency	Scurvy	Lack of Vitamin C
Hereditary	Haemophilia	Two recessive alleles in X chromosomes
Physiological	Diabetes	Body's inability to produce or use insulin efficiently

Part (b) required candidates to examine a pie chart of statistics on HIV and AIDS in the Caribbean, and on other aspects of recognition and control of the spread of the disease. Part (b) (i) asked candidates to indicate, based on the information in the pie chart, the three common ways in which HIV and AIDS is spread in the Caribbean. Many candidates who were otherwise performing well on the question failed to include the category – *unknown* – which was the second highest ‘cause’ according to the data provided. Part (b) (ii) asked candidates to suggest ways in which people in the Caribbean can reduce the spread of the disease. This was very well done with candidates generally obtaining full marks for this part of the question. In Part (b) (iii), which asked for two symptoms of AIDS, candidates too often failed to gain full marks since their responses tended to be vague or unclear. Vague and unclear responses included ‘hair loss’ and ‘loss of weight’. For the latter candidates would have had to qualify the weight loss as *severe* or *rapid* to obtain the marks. Candidates who suggested that loss of hair is a symptom of AIDS were not rewarded.

### Paper 03 – Extended Essay

Candidates’ performance on this paper showed a decline over performance in June 2006 with the mean at 41% compared with the previous mean of 45%. Indeed some observations about candidate performance remain constant. Candidates demonstrated a continuing ability to write at length about biological events, principles and concepts. This year, as was the case last year, their writing generally seemed more focused on the topics at hand. There was some evidence that in spite of time allotted for reading the paper, candidates missed key words in the questions and provided answers which were off the point, but this occurrence was less frequent than in previous years. Nevertheless, candidates should be advised continually that *the reading time should be used to read through each question carefully, highlighting key words on which the questions hinge, so that they would be less likely to misread and misinterpret questions. The reading time should also be used to plan their responses so that they are more likely to stick to the relevant points on each topic.* It is clear that much time is spent on teaching and learning the content of the syllabus. However, more attention needs to be paid to developing important examination techniques which will allow candidates to make the best use of what they know.

#### Question 1

This question required knowledge of the role of the ribs and lungs in breathing, and also required candidates to apply their knowledge of the respiratory process under specified conditions. It also explored candidates’ knowledge of the role of iron in the blood’s oxygen-carrying capacity as well as the effects of cigarette smoking on the body. This was the more popular of the question pair in Section B, and candidate performance was relatively good.

In Part (a), candidates were to describe, with the aid of a diagram, how the rib cage and lung function in breathing. Diagrams generally showed recognizable differences in relative positions of the rib cage and lung during inhalation and exhalation and generally provided an adequate description of the functioning of the relevant muscles. Thus, many candidates were able to acquire the marks for this section. A candidate’s description that gained full marks was presented in tabular form:

Inspiration	Expiration
Ribcage moves up and outwards	Ribcage moves down and inwards
Lungs expand	Lungs contract
Intercostals muscles relax	Intercostals muscles contract
Diaphragm relaxes	Diaphragm domes upward
Volume of thorax increases	Volume of thorax decreases
Pressure decreases	Pressure increases

Part (b) of the question tested candidates' ability to apply their knowledge of oxygen transport and the impact of smoking on the lungs. In Part (b) (i), candidates were asked to give two reasons why well-trained athletes recover more quickly after completing a race than untrained athletes. This part of the question was fairly well done with candidates generally obtaining about half the allotted marks. However, candidates seemed unclear about the concept of oxygen-debt and its relationship to lactic acid production. Candidates were expected to refer to *the oxygen-carrying capacity of the blood; quick removal of lactic acid from the muscles of well-trained athletes; more efficient lungs due to deeper breathing; more rapid delivery of oxygen to the tissues.*

Well-trained athletes recover more quickly after completing a race because they have ... mastered correct breathing techniques. They also have a lot of experience in running and have trained doing cardiac exercises so that their body is stronger and have become accustomed to loss of breath and fatigue.

Part (b) (ii), which asked candidates to suggest reasons for advising against athlete's smoking was also fairly well done. Candidates were expected to include in their responses factors that would impact on the athlete's ability to take up adequate amounts of oxygen and supply to their muscle cells, such as: *reduced oxygen-carrying capacity; reduced gaseous exchange efficiency; impaired breathing; or role in causing performance reducing diseases such as asthma, bronchitis and lung cancer.* A good candidate response was as follows:

Cigarette smoke contains carcinogens and tar which can coat the lungs which decreases the surface area of the lungs, thus decreasing its efficiency and lowering the capacity to take up a large amount of oxygen. Smoking leads to inhalation of carbon monoxide which binds unfavourably with haemoglobin in the blood. As a result less oxygen is transported since carboxyhaemoglobin is formed and thus the athlete would perform at a lower level.

Part (c) of the question examined candidates' ability to apply their knowledge of mineral iron as a requirement for red blood cell production. This part of the question was generally fairly well done. Candidates were to consider that female athletes: *are more active; more iron was needed for more haemoglobin production; increased oxygen-carrying capacity; or that females lose blood during menstruation which had to be replaced.* A response that obtained full marks was:

... women athletes exert themselves more than other women. The iron helps them to make more haemoglobin and as a result they have the ability to carry more oxygen in the blood ....

## Question 2

This question tested the candidates' knowledge of meiosis and mitosis and their ability to use genetic diagrams to explain the inheritance of blood groups. The question also examined candidates' knowledge of genetic variation and some of its implications. Performance on this question was quite good. This was the less popular of the question pair in Section B, but candidate performance was very good.

Part (a) asked candidates to describe, with the aid of diagrams, the process of meiosis. Most candidates had some idea about reduction division; however, many did not seem to realise that reduction division occurred during the first stages of meiosis and they often failed to distinguish the maternal and paternal chromosomes, and confused how the chromosomes behaved during the process. Nevertheless, candidates were able to gain at least half the marks allotted to this question. In answering this part of the question candidates were expected to describe and illustrate: *initial reduction division; second division resulting in four non-identical cells; 1 cell – 2 cells – 4 cells; distinguish maternal from paternal chromosomes and show halving of the chromosome number.* Part (a) (ii) required candidates to show the differences between meiosis and mitosis. This part was generally well done. Candidates were required to show that the: *chromosome number was retained in mitosis and halved in meiosis; two daughter cells produced in mitosis and four in meiosis; identical cells are produced in mitosis and non-identical cells/gametes in meiosis.* Good responses to this part of the question were:

Two new cells are formed by mitosis whereas four are formed by meiosis. Homologous chromosomes pair for meiosis but not for mitosis.

Meiosis results in the production of four daughter cells whereas mitosis results in the production of two daughter cells. Meiosis results in the production of haploid cells whereas mitosis results in the formation of diploid cells, identical to the parents.

Part (b) of this question was generally well done by the candidates. They were required to show how knowledge of genetics can be used to explain how a couple with blood types A and B respectively could produce a baby with blood type O. Candidates were familiar with the appropriate genetic diagrams and were able to demonstrate that the parents with the relevant blood types showed the heterozygous genetic condition for their respective blood groups rather than the homozygous or co-dominant genotypes. They were thus able to illustrate that there was a 25% chance that an offspring of theirs could have a completely different blood group from either parent. Candidates also used genetic symbols appropriately and there has been a marked improvement in candidates' ability to treat with a genetics question of this nature.

Part (c) of the question asked candidates to suggest reasons why farmers tended to choose a single variety for their crops and to highlight some implications of variation. Part (c) (i) was well done. Candidates were able to provide an appropriate response for the farmer's choice of a single variety. They were expected to include in their responses ideas such as: *desirable characteristics; high sugar content, easy to reap; grow fast; mature at the same time*. A good response to this part of the question was:

They tend to choose a single variety for their crops because it is easier to maintain since the same equipment and procedures are required to maintain the whole crop; fertilization is easier ... the sugarcane produces similar offspring time after time. Sugarcane plants form from the ratoons so that new sugarcane growth is quick and easy.

Part (c) (ii) asked about the implications to the farmer of insect infestation of their sugarcane crop. This part was fairly well answered although some candidates seemed unfamiliar with the term 'implications'. Candidates were expected to frame their responses around an understanding of the concepts of: *monoculture/same genotype; loss of entire crop possible; rapid build up of the pest population/ much food available; and /or cost to the farmer*. Good responses for Part (c) (ii) were:

The implication to the sugarcane farmers of insect infestation of their crops is that when the insects attack since they are of the same variety all of their crops will be affected (destroyed) and they would lose a large amount of money; since they are of the same variety they all have the same weaknesses and vulnerabilities.

... these crops are being produced by the same set of genes. When disease strikes one it will affect all, because they will all have the same susceptibility to it.

One misconception observed in the candidates' responses to this question was that 'meiosis occurs in animals and mitosis occurs in plants'. It should be noted that **these processes – meiosis and mitosis occur in both plants and animals**. Another misconception is that fertilization and cell division (meiosis) are the same.

### Question 3

This question tested candidates' knowledge of the internal structure of the leaf and the roles different parts play in photosynthesis. It also required candidates to apply their knowledge of the role of food storage organs to the plant's survival of adverse conditions and productivity. This was the less popular of the question pair in Section B, but candidate performance was very good.

Part (a) of the question required candidates to describe, using a fully annotated diagram, the internal structure of a leaf in relation to its role in photosynthesis. This part of the question was fairly well done and discriminated between those candidates who knew the structure and function of the leaf from those who had a passing familiarity with plants and photosynthesis. Some candidates, who perhaps did not read the question well, provided a stereodiagram of the leaf showing part of the internal structure and much of the external

the leaf that were clearly involved in photosynthesis – palisade and spongy mesophyll; xylem and phloem (vascular bundle); chloroplasts; stoma/guard cells; sub-stomatal air spaces and give the functions of each part identified in the photosynthetic process. For example, the *chloroplasts/mesophylls are the sites of the photosynthetic process, that is, the conversion of carbon dioxide and water to carbohydrates; or the palisade arranged for maximum exposure to sunlight which is required in the photosynthetic reaction; xylem transports water to the site of the reaction or phloem takes food away from the site of production to allow for the continued reaction to occur, and so on.* Candidates were not rewarded for identifying the ‘epidermis’ of the leaf unless they indicated that because it was a clear layer it did not impede the entry of light. Part (a) (ii) was very well done. Most candidates were able to provide a balanced equation which included the requirement of sunlight and chlorophyll, in response to the question that asked for a balanced, summary equation of the photosynthetic process.

In Part (b), candidates were asked to explain the impact of loss or removal of leaves from plants. In part (b) (i), they were required to explain how plants which had lost all their leaves were still able to survive. Candidates performed fairly well on this part of the question as several recognised the role of storage organs and that vital processes were still occurring. Candidates were expected to refer to: *buds renewing growth; storage of food in roots and stems; conversion of stored food, or presence of cambium/meristems.* Candidates rarely mentioned cambium or meristems and it should be emphasised that these tissues have important roles in the growth of plants. Good responses to this part of the question were:

Even though they have lost their leaves, they still have food stored in storage organs and other parts of the plant. This food is used to continue respiration and other characteristics of living organisms. Also, it may be used in growth of new leaves. The plant’s stems and roots are still intact so that the plant would still have a good supply of water and oxygen and mineral salts which are dissolved in the water.

Many trees will readily survive despite the loss of all their leaves because the food made in the leaves is not all stored in the leaves. The leaves are simply the site of photosynthesis and they make more food than is required, hence some of it is stored in various parts of the tree to be used when the leaves are not able to photosynthesise or the leaves are lost. The glucose produced is converted to starch which is carried by the phloem tubes to various plant organs, and when energy is needed respiration takes place. Therefore, the tree will be able to survive sometimes without its leaves using the stored food until leaves can be grown again.

In part (b) (ii), candidates were to suggest why gardeners sometimes removed leaves and branches from trees in order to improve yield. Candidates often recognised that there would be more food for non-photosynthetic parts and growth was encouraged. Some candidates also included that the practice helped reduce the spread of disease. Candidates were expected to frame their responses around the ideas that it: *encouraged growth in other parts, more water became available to remaining leaves; more food available for non-productive parts; more light to remaining leaves; more overall efficiency of the plant, faster growth.* The following responses earned full marks:

When there is overcrowding of leaves there is competition, and photosynthesis occurs at a slower rate as light energy has to be incorporated into each leaf and also leaves at the top of the branch hinder light from entering leaves lower than them. By removing leaves competition is reduced and all leaves are able to photosynthesise. Hence plants grow quicker and with a better yield.

Some leaves and branches can often be diseased and could potentially cause the entire plant to become diseased and die. By removing these leaves or branches it allows for new leaves or branches to be formed and new fruit and greater yield obtained. Sometimes, branches die and need to be cut off, so that new branches can be grown and yield increased. The taking out of the old leaves and branches produces more leaves and branches.

Disturbing misconceptions here are that xylem stores water and phloem stores food and stomata allows water to enter the leaf.

#### Question 4

The question dealt with candidates' knowledge of the digestive system and the events that occur during the digestive process. It also examined candidates' knowledge of the ways in which the body defends itself against disease as well as the social and economic implications of communicable disease. This was the more popular of the question pair in Section B and candidate performance was relatively good.

Part (a) of the question asked candidates to explain how the human digestive system is able to function effectively and also protect itself from disease-causing organisms. In Part (a) (i), candidates were to use an annotated diagram to explain how the human digestive system ably functioned. This part of the question was fairly well done. Candidates generally had a grasp of the functions of the major parts of the digestive system. However, many candidates were unable to produce a diagram that accurately represented the components of the human digestive system starting with the mouth. Far too many candidates omitted the mouth. Candidates often failed to name the main parts of the digestives system. They were expected to name the: *mouth, stomach, duodenum* and *small intestines*. They also failed to distinguish between the small and large intestines. In terms of annotation, candidates also failed to describe the roles of the regions of the small intestines, in particular, in digestion. They were expected to include in their annotation that the *duodenum was the place where pancreatic juice with a range of enzymes continued digestion of carbohydrates, proteins and fats*. They were also expected to indicate that the *small intestines was the site for completion of digestion* and to that end *intestinal juice contained a variety of enzymes that completed the breakdown of the carbohydrates, proteins and fats*. Annotations which earned full marks included:

Stomach – receives food and uses muscular contractions to churn food. It secretes gastric juice. Gastric juice contains the enzymes pepsin which begins digestion of proteins; rennin which clots soluble milk protein and hydrochloric acid which provides an acidic medium for these enzymes...

Duodenum – receives chyme from stomach and contains sodium hydrogen carbonate which neutralizes hydrochloric acid from the stomach; contains pancreatic juice which contains several enzymes that continue digestion of carbohydrates, proteins and fats.

Ileum – intestinal juice is produced here for the completion of digestion and where reabsorption of digested materials takes place.

Part (a) (ii) was generally well done. It asked candidates to indicate one way in which the digestive system protects itself. Candidates often referred to the low pH caused by secretion of hydrochloric acid that killed bacteria. Some candidates also mentioned anti-peristalsis that cause tainted food to be forcibly expelled.

Part (b) of the question asked candidates about the ways in which the body defends itself against disease organisms and to offer reasons for defending itself in different ways. Performance on this question was quite variable. Many candidates indicated the *role of phagocytes* and *clotting* were mechanisms for defending the body against disease organisms. Candidates also included *natural immunity* and the *production of antibodies*. In some instance candidates tended to incorrectly describe the process of immunity. However, candidates had a lot more difficulty explaining why the body had different ways of defending itself. Candidates were expected to include in their responses that: *there were different types of pathogens/disease-causing organisms; differing means by which organism entered /invaded the body; or that a variety of mechanisms ensured better chances of survival*. Responses that gained full marks to Part (b) were:

... the body protects itself from disease organisms ...through the clotting of the blood when a cut is made on the skin and the presence of white blood cells which remove harmful bacteria and organisms by means of phagocytosis. This is part of the body's immune system. The body must have several ways of protecting itself because vectors of disease are numerous and must be dealt with differently depending on the situation.

The body defends itself ... by forming blood clots ... when there is an open cut which can lead to infection. ... also by lymphocytes and phagocytes in the blood which attack disease-causing organisms detected in the body. It is important that the body has different ways of defending itself as various disease-causing organisms are present in the environment surrounding us and they have

Part (c) of the question required knowledge about communicable diseases and how they are spread. In Part (c) (i), candidates were asked to define a communicable disease. Most candidates were able to provide a response that recognised that this type of disease was *transmitted from one individual to another*. However, few candidates seemed to recognise that these disease were *usually caused by pathogens*. Part (c) (ii) asked candidates to explain why countries should be concerned about any outbreak of any communicable disease. This part of the question was fairly well done. Candidates were expected to include in their responses considerations about: *increased travel between countries so pathogens transmitted across borders more rapidly; variety of means by which travelers enter and leave countries; pathogens mutate and strains can infect humans; vaccines take time to develop; or cost to countries in terms of lives and resources lost*. A good response to Part (c) (ii) was:

Countries should be concerned about any outbreak of a communicable disease because if introduced into a country, they can spread very quickly from one person to another via a pathogen or vector and can result in rapid loss of work force if many people become infected at the same time. This would also be economically disadvantageous as a vaccine would need to be developed.

### Question 5

This question required knowledge of decomposers and their role in the carbon cycle. The question also sought candidates' knowledge about greenhouse conditions and global warming and their possible effects. While this was the more popular of the question pair in Section C, candidate performance was relatively weak. Candidates continue to show a lack of understanding of decomposers and their role and functions in the recycling of natural elements.

Part (a) (i) of the question asked candidates to define decomposers. Candidates hardly ever provided an adequate definition for the term. They were expected to indicate that *decomposers are microorganisms that cause decay; breakdown complex organic to inorganic compounds; and form simpler compounds in the process*. In Part (a) (ii), candidates were required to explain the role of decomposers in the carbon cycle. This part of the question was also not very well done. Candidates generally failed to recognise that the *microorganisms fed on the dead bodies/waste materials/urine or faeces of organisms; obtained their nutrients from them; the materials derived are incorporated into the bodies of the decomposers; used in respiration during which process carbon dioxide is released back into the atmosphere*. A good response to this part of the question was:

The bacteria feed off these dead organisms which further break down their organic structure and release carbon dioxide into the atmosphere by the process of respiration. This is the recycled carbon dioxide.

In Part (a) (iii), candidates were to identify two types of decomposers and describe the characteristics that they possess that make them suited to their role as decomposers. Candidate performance on this part of the question was only fair. Far too many candidates still consider earthworms as decomposers. Candidates should note that decomposers fall within the broad categories, *bacteria* and *fungi*. Candidates should also note the characteristics the bacteria and fungi possess that make them suited to their role as decomposers include: *their inability to otherwise manufacture food, for example, fungi have no chlorophyll; they secrete enzymes that digest organic matter to obtain their nutrients; they are capable of anaerobic respiration; or they break down carbohydrates in low oxygen conditions*. A response that earned full marks in this part of the question was:

Fungi and bacteria can both replicate easily and grow very quickly so that there is a mass of them that is able to feed on the matter... . They possess particular enzymes to enable them to break down the organic matter so it would be simple for it to diffuse.

Part (b) of the question required candidates to display their knowledge and understanding of the greenhouse conditions and global warming and their implications. Candidates generally had some ideas about greenhouse conditions and global warming, but there were some obvious misconceptions especially about global warming. In Part (b) (i), candidates were required to indicate the benefits of growing plants under greenhouse conditions. To a large extent candidates were able to provide an appropriate response. They often indicated that it produced high temperatures which helped to increase growth. However, they hardly made reference to

was *high humidity*. In Part (b) (ii), they were to suggest reasons why global warming is not generally desirable. Candidates performed well on this part of the question. They captured in their responses ideas such as: *raising of global temperature; melting of ice caps/increasing of sea levels; submerging of wetlands; increased flooding; changing weather patterns; and/or upsetting the balance of nature*. A good response was:

Global warming is not desirable because it results in the subsequent melting of the ice caps which would increase sea levels and result in the subsequent ‘drowning’ of vast land areas. Also, ... global warming may increase rainfall in some areas, but there may be drought in others. In the Caribbean, drought would result in decreased agricultural production and more irrigation....

Candidates generally provided reasonable responses to Part (b) (iii) of the question, which asked candidates to suggest why global warming might be advantageous. They were expected to include ideas such as: *cold countries might become more temperate and habitable; new areas might become arable/fertile*. A response that earned full marks was:

Global warming could extend the growing period of most crops because higher temperatures would last longer (extend the growing period) which is necessary and could mean more photosynthesis and as a result a country could export more and gain more income.

Major **misconceptions** observed in this question included:

- (i) The depletion of the ozone layer is caused by global warming. It should be noted that there is no direct link between global warming and the depletion of the ozone layer.
- (ii) Global warming increases the incidence of skin cancer. Global warming does not mean more exposure to sunlight or depletion of the ozone layer. Depletion of the ozone layer allows more exposure to ultraviolet radiation which may increase the incidence of skin cancer.
- (iii) Greenhouses have more carbon dioxide available hence the increase in photosynthesis. It should be noted that in greenhouses temperature is high and thus photosynthesis takes place at a faster rate, not that there is more of it.

#### Question 6

This question asked candidates to distinguish between selected ecological terms. It also examined their ability to apply their knowledge of ecology to conserving and restoring flora and fauna in selected habitats. This question like its counterpart in this section was also not well done.

Part (a) of the question asked candidates to distinguish, with the aid of examples, between the following biological terms:

- Biotic and physical
- Food chain and food web
- Community and population
- Habitat and environment

This part of the question was fairly well done. In particular, candidates were unable to distinguish adequately between biotic and physical, habitat and environment and to a fairly large extent between community and population. Far too many candidates believed that the physical environment meant what they can see and hold. Few candidates related the physical environment to the non-living or abiotic components of the environment as opposed to the biotic or living components. Candidates were expected to indicate that the term biotic refers to *living things – plants and animals* while the physical environment referred to the *non-living* component of the environment such as *temperature, pH, soil, oxygen, or rainfall*. Candidates tended to use very vague terminology to distinguish between habitat and environment, especially in the case of the



latter. They should consider the habitat as *they type of place where a particular organism lives*, for example, *pond or leaf litter*. The environment on the other hand refers to the *physical and biotic factors that affect an organism*, for example, *the marine environment and any salt-water fish, such as, grouper that is affected by the watery medium and other organisms within it*. Candidates were expected to indicate that a community describes *all organisms of the different species in a specific habitat/ several species in a habitat*, for example **all, fish (guabines), tadpoles, water lilies, pond-skaters and microorganisms in a pond**. A population describes a group of organisms of the same species in a specific habitat, for example, the water lilies or the guabines in the pond.

In Part (b), candidates were asked to suggest biological factors that wildlife authorities should consider and precautions they should take before giving the public access to wildlife reserves. Candidate performance in this part of the question was fair. They were generally able to identify a number of factors and provide appropriate precautions, although it was expected that they would have used more biological jargon and expressions in their responses. It was anticipated that candidates would have included in their responses factors such as: *species endangerment/numbers; species life cycle; physical conditions, for example, terrain; and/or human activity that threaten wildlife*. Their precautions should have included ideas such as: *means of preserving numbers; maintenance of habitat features; avoidance of disrupting critical/ vulnerable stages in organisms' life cycles; reduction of destructive human activities, for example, pollution; and /or avoidance of species removal* and other relevant strategies. A good response was as follows:

Wildlife authorities should consider whether any of the species of the wetland are endangered, as giving public access to an endangered species could result in the species becoming extinct. If some species are endangered, authorities should advise that the species not be touched... the authorities may need to consider if there are any organisms, be it plants or animals that may be dangerous to the public, so that the public can keep a safe distance away. This protects the organism from violent reactions from itself and humans. Making these areas protected and restricted prevents any injury or casualty to both humans and organisms.... The type of soil in the area if it is loose, soil erosion will be a huge problem. The authorities should enforce a limit on the number of people allowed in the area and also on their activities.

In Part (c), candidates were asked to suggest the main lessons learnt from the rapid degradation of coral reefs when indiscriminately used by humans. This part of the question was a bit challenging to candidates. They were expected to recognise and refer to in their responses: *the fragile nature of coral reefs; the impact of human activities like snorkelling and walking on the reef organisms; the loss of access and importance when the reef is destroyed; the length of time it takes for corals to grow and/or display general understanding of the biology of corals*. A response that gained full marks was:

Corals are delicate and can easily be damaged or destroyed by humans, especially by stepping on them. Also, corals grow very slowly, so any damage to a reef cannot be quickly rectified and replenished. Visitors to the reef should not be allowed to walk on or touch (especially break off) corals from the reef.

## **PAPER 04 – School-Based Assessment**

### **GENERAL COMMENTS**

Performance on the School-Based Assessment was commendable. The syllabus coverage for all Centres was generally good and it was evident that there was some attempt to conduct practical activities for all the skills. However, while the skill of Observation, Recording and Reporting (ORR) was generally well done, Analysis and Interpretation (AI) and Planning and Designing (PD) seemed to present candidates with the most difficulty. It is recommended that more practical work, and work providing opportunity for developing these specific skills, form a greater part of the Biology course. In general, practical work should have an experimental approach that facilitates the development of critical experimental skills which is a major goal of the SBA. Efforts must also be made to include fieldwork for each batch of candidates.

A review of previous school reports will provide further suggestions for developing practical skills. Further suggestions are made/reiterated in this report and each teacher is alerted to the specific strengths and weaknesses displayed by their candidates in the Moderation Feedback Form sent to schools from CXC, after moderation. Teachers should also review the 2002 school report to obtain an overview of the moderation processes and the expectations of the moderators.

While the quality of the books submitted from several Centres was good, there are still some Centres that submitted books without the requisite information. The CXC Biology syllabus provides guidelines for the preparation of practical books for submission. Some of the requirements include: a Table of Contents with aims of the practical activities, page numbers, dates, and a clear indication of the skills being assessed. In addition, the marks awarded for each practical activity must be placed aside the practical and not listed at the front or back of the books. There must also be clear and specific indication of the activities that are used for the SBA.

The moderation exercise is too often hampered by poor mark schemes. These must be prepared and submitted with due care and attention. Mark schemes must be legible and preferably bound together instead of on loose sheets of paper. There must be a clear and direct relationship between the marks awarded to the appropriate activities in the practical books and to the marks on the tally sheets. It should also be noted that no more than two skills should be assessed in a practical activity.

The following is a list of criteria which teachers should follow in marking SBA activities.

- Marks should be awarded for each skill separately. It is noted that in some cases, marks were given for each skill then tallied to give a composite score.
- Marks awarded to students' work should be a fair indication of its quality. Too many students received high marks for work that obviously fell short of the CXC standard. This was particularly noticeable for Planning and Designing, Analysis and Interpretation, and Drawing. When the CXC standard is not observed there is great disparity between the teacher's score and that of the moderator. This circumstance is usually **disadvantageous** to the students.
- Marks submitted on the moderation sheet should reflect the candidates' marks in each of the samples. Consistency of marking and submission of marks relate to the reliability of the process and thus acceptability of marks submitted.
- Teachers are once again reminded that body fluids such as saliva, blood and urine are not to be used for practical work. These can be sources of infection and may have serious legal implications should a student become infected while conducting practical work. Plant materials must be removed from books before they are submitted to CXC, since these are also potential agents of infection when moved from place to place.
- Fieldwork, both quantitative and qualitative aspects, is critical to the study of Biology and must be included in the SBA submissions

The Moderation Feedback Form, which is sent to each Centre, provides constructive and useful information relevant to the particular teacher(s). This form offers specific recommendations and is intended to assist teachers in the planning, conducting and assessing practical work – in the laboratory and field. Improvement of students' practical skills will have a direct influence on candidates' overall performance in the Biology examination, since certain questions, notable Question 1 on Paper 02, are based on knowledge and application of these practical skills.

## SPECIFIC COMMENTS ON THE ASSESSMENT OF SKILLS

### **Observation, Recording, Reporting (ORR)**

These skills appear to have been mastered at most Centres. For most of the work observed, the method was clearly described with logical sequence of activities. The tables and graphs were clear and provided adequate details which allowed for clear description and discussion of the experiment. It was also observed that except for a few Centres, the past tense was correctly used in the presentation of the report on the practical activity.

The importance of fieldwork is reiterated here. At some Centres little or none is being done. Many Centres that attempted fieldwork frequently neglected quantitative or qualitative investigations. Both aspects of fieldwork are expected. Investigations need not be elaborate but students should be given the opportunity to explore the environment and make observations about the relationships among living organisms and their environment.

### **Drawing (Dr)**

The number of drawings included in candidates' practical books, as well as the quality of the drawings, continue to be of concern to the Biology Examining team. At too many Centres poor drawings were awarded high marks. Drawings are not expected to be works of art, but they should demonstrate an adherence to the guidelines for accuracy, clarity, labelling and magnification. Students have to be given several opportunities to develop drawing skills. The larger the number of drawings students have to produce, the more opportunity they have to practise, and develop the skill. It is also emphasized that drawings must be practised from actual specimens and not from textbooks. This comment has been stressed in several schools' reports.

Teachers must ensure that their students draw samples of **flowers, fruits, storage organs and bones**. Additional examples may be included in practical books. However, **microscope drawings should not be used for SBA**. It is very useful for students to see and attempt to record what they do see under the microscope but at this level these drawings should not be used for SBA. Similarly, dissections may help students to understand structures such as the digestive system but they are too complex to be drawn accurately at this level. These difficult drawings do not provide a fair test of ability at this level.

### **Analysis and Interpretation (AI)**

This skill continues to present problems for the majority of candidates. The processes involved in demonstrating this skill are reiterated here.

Discussions are expected to provide some background information or the general principles on which an investigation is based. Results should then be explained. When a control is used it provides a point of comparison for the experimental set up in which a particular variable has been omitted. This comparison should be included in the discussion as it is the key to drawing the conclusion. Conclusions should relate directly to the aim of the investigation. Students should also be reminded to discuss at least one limitation of the investigation. It is important for them to recognize that the conditions present in a school laboratory are rarely ideal.

Many teachers continue to use questions to stimulate discussion. This device is good for helping students to develop their AI skills. However, they should not be used excessively, nor should they be the only means of assessment. These questions must guide students to provide the required background information, give explanations for the results, draw conclusions and show an awareness of possible limitations. The information provided in this way should then be written up as a paragraph of continuous prose as is normally done for the discussion/ conclusion. In many cases, candidates seem to have learnt a formula for writing up the discussion but showed no real understanding of how to interpret their own results. As a learning strategy teachers may ask their students to orally explain the results to obtain a clearer view of their understanding and to help them develop their analytical skills.

It should be noted that food tests on their own are not appropriate for assessing AI. Simple investigations can be designed in which food tests are used. For example, students can be given unknown mixtures and asked to

presence of a particular food before and after digestion by an enzyme. These types of exercises will allow students to develop the necessary skills. Knowledge of the food tests and the nutritional requirements can then provide the background information on which they will base their conclusions.

Moderators were also concerned about the narrow range of investigations assessed for AI. With the exception of patterns of growth in seedlings, very few candidates seemed to have been exposed to investigations other than experiments. Investigations that require collecting observations over a period of time are ideal for discussing limitations as they lack controls and so many variables may change. These limitations can then be used as the basis for Planning and Design exercises. For example, students can be asked to find out which of the flowers in a garden butterflies prefer or what types of moths a house lizard eats by completing a table of observations over a period of days or weeks. They can then use the observations to develop a hypothesis and design an investigation that would test it.

### **Manipulation and Measurement (MM)**

As in previous years, the marks for this skill were good. However, as was stated in previous reports, in many cases there was reason to believe that these marks were not the result of rigorous marking. If virtually all students in a class gain full marks on an activity, perhaps the task is not demanding enough or the criteria not detailed enough to allow the necessary discrimination between different levels of performance. It is important that students be exposed to a wide range of apparatus and their use in collecting data. This would help to ensure the development of the skill and give a fairer assessment of student competence in MM. Teachers are reminded that marks for MM must be written down in the laboratory books next to the practical exercise for which they were awarded, and mark schemes and detailed criteria submitted as done for all other skills.

### **Planning and Designing (PD)**

Performance on this skill was fair. Most experiments designed by the students indicated that there was some understanding of the procedures involved in planning and conducting an experiment. There are still a few areas of difficulty where candidates were unable to state their hypotheses clearly and relate the aim to the hypothesis. In some instances, there were no replicates in the investigations

There is room for more creative experiments. Teachers should take examples from their environment that would challenge the ability of their students. It is also important that development of the skill start with the commencement of the teaching of the syllabus. In many cases it was obvious that practical activities targeting the development of the Planning and Designing skill were among the last set of activities in which the candidates engaged prior to the examinations. Figure 1 is a noteworthy submission from 2005 SBA, which clearly illustrates how a Planning and Designing activity might be effectively developed.

**Example:**

This Planning and Designing activity submitted by a centre was based on the observation that “*A boy notices that all the trees around his yard except the grapefruit tree were infested with ‘duck’ ants*”. The students were required to plan and design an experiment to determine what was responsible for the difference in infestation. An example of an appropriate hypothesis and a relevant aim for investigating the hypothesis was:

***Hypothesis:** ‘Duck’ ants will appear on some trees but will not be present on grapefruit trees because the leaves contain a chemical that repels the ants*

***Aim:** To investigate whether ‘duck’ ants are repelled by a chemical from the leaves of the grapefruit tree.*

There was a clear description of the materials and method. Students planned to extract the substance from the leaves of the grapefruit tree, which may be responsible for the repellent effect, along with extracts from the leaves of other trees as an appropriate control. The ‘duck’ ants would then be placed near drops of each of the extracts in petri dishes. The measurable variable would be the number of ‘duck’ ants that leave or remain in each dish. Results would then be tabulated and subsequently discussed.

As stated by the candidates, one limitation may be that ‘the chemical in the leaves that cause the effect on the ‘duck’ ants may be affected by the extraction’. Appropriate marks were awarded for the various aspects of the experiment.

**Figure 1.** Example of a Good Planning and Designing Activity

**CARIBBEAN EXAMINATIONS COUNCIL**

**REPORT ON CANDIDATES' WORK IN THE  
CARIBBEAN SECONDARY EDUCATION CERTIFICATE  
JANUARY 2008**

**BIOLOGY**

**Copyright © 2008 Caribbean Examinations Council ®  
St Michael Barbados  
All rights reserved**

## **BIOLOGY**

### **GENERAL PROFICIENCY EXAMINATIONS**

**JANUARY 2008**

#### **GENERAL COMMENTS**

##### **Introduction**

As customary the January 2008 sitting of the CXC examination in Biology consisted of four papers:

Paper 01 – Multiple Choice

Paper 02 – Structured Essay Questions

Paper 03 – Extended Essay

Paper 04/2 – Alternative to the School-Based Assessment

Performance of candidates in this examination showed many similarities compared with the performance in previous sittings of the January examination. Consequently, a similar number of candidates were able to obtain grades between I and III. However, there was a drop in the performance at the Grade I level in particular and there is adequate evidence to suggest that more attention must be paid to the comments and suggestions continuously offered by the Examining Committee. A relatively large proportion of the candidate population makes fundamental errors that prevent them from demonstrating their best efforts. The following comments and suggestions are ongoing and of critical importance.

- Candidates must improve their test-taking skills. This includes practice in reading questions carefully and planning responses so that answers are organized in a logical and coherent manner.
- Candidates continue to waste a lot of valuable time providing irrelevant information in the essays. They should focus on key words such as ‘describe’ and ‘explain’ when reading the questions and be guided by the mark allocation and quantitative descriptors within the text of the question as far as possible.
- There was also the question of choice of terminology and descriptions provided. Familiarity with biological jargon allows candidates the opportunity to express themselves more accurately and reduces errors caused by oversimplification.
- Candidates should pay more attention to the stimulus material provided in the questions, especially in Paper 02. The stimulus material is meant to guide the candidate to the expected responses. Too often candidates respond by providing obscure information on the topic that do not relate to the scenario presented.
- More emphasis should be placed on practical skills and the candidates’ ability to demonstrate these skills in responding to questions on the Alternative to SBA paper. Too many candidates seemed unfamiliar with basic laboratory equipment and material and even the simplest of biological/scientific methods. Candidates demonstrated particular weakness in identifying precautions and limitations of an experiment, as well as in stating aims and formulating hypothesis.

- The spelling of common biological terms is generally so poor that candidates cannot be rewarded with marks. It is also difficult to explain why candidates would incorrectly spell biological terms used in the question.

### **PAPER 01 – Multiple Choice**

Paper 01, consisted of 60 multiple-choice items. Performance on this paper was similar to that of last year's. Some of the topics that *continue to be* problematic for candidates were:

- Aspects of ecology including feeding relationships and food chains
- Cell structure and function
- Specifics of photosynthesis
- Specifics of respiration
- Cell specialisation
- Morphology of root, stem and leaf
- Phloem structure
- Reflex arc
- Aspects of nutrition, for example, role of different vitamins
- Aspects of respiration and excretion
- Joints
- The functioning of the pupil in the eye
- Metabolic rate and effect on the body temperature
- Distinction between meiosis and mitosis
- Distinction between population and community
- Sampling methods

### **PAPER 02 – Structured Essay Questions**

Paper 02 consisted of five short-answer structured questions of which the first was the data analysis question worth 30 marks. This paper tested all profile skill areas identified in the Biology syllabus. Candidate performance on this paper declined in 2008 over 2007, with fewer candidates falling within the upper grade bands. However, once again there were no modes at the extreme lower end, that is, below 4.

Candidates were able to attain marks across the allotted range for all but two of the five questions. However, for more candidates to give their best performance attention must be paid to observations and suggestions the Biology examiners have repeatedly noted. In particular, candidate attention is drawn to the use of the stimulus material in responding to the questions and the guidance provided by the spaces allotted to each question – answers should relate to the stimulus material and should be kept within the allotted spaces. ***Candidates must note that they are not required to repeat the questions to begin their responses.***

#### Question 1

This question dealt with some practical aspects of Biology including interpreting graphs of enzyme activity, methods of obtaining data from an enzyme investigation and sources of error, as well as enzyme activity in softening meat. Candidates were also required to display their knowledge of the conditions necessary for germination and the role of microorganisms in natural cycles. Candidate performance on this question did not quite meet expectations.



Part (a) (i) required candidates to interpret a graph which showed a decreased rate of enzyme reaction in the first part and an increasing rate of reaction in the second part. This was not at all well done, and most candidates failed to gain the allotted marks. They generally gave the values indicated on the graph without recognizing that they were to refer to the reaction rate. In Part (a) (ii) in which candidates were expected to estimate the optimum temperature for the enzyme in the reaction, they also did not do very well. They did not seem to recognise that the optimum temperature for the enzyme would be that at which the fastest/near the fastest rate of reaction took place, which will be reflected on the graph as the shortest time.

Part (b) asked candidates to represent the data shown in the graph on a table. Apart from the traditional errors made in constructing tables including the omission of the title and inappropriate headings, many candidates failed to correctly fill in the data, especially in terms of sequence and selection of the target values. This showed some of the confusion in reading the graph and unfamiliarity in distinguishing the *manipulated variable* from the *responding variable*. Too many candidates had the manipulated variable in the right-hand column.

Part (c) of this question which asked about an investigation involving the use of the enzyme amylase, was not very well done. In Part (c) (i), they were to identify the materials and apparatus and outline the method they would use and in Part (c) (ii), they were to identify one source of error. Candidates were expected to include apparatus such as *water-bath, thermometer, timer, white tile and a source of the enzyme* and include in their method means of *setting up the water-bath and maintaining its temperatures, preparation of the substrate, removal of experimental solution at intervals and use of iodine to detect starch* among other ideas. Sources of error would be obvious as *maintaining the temperature of the water bath, quantity of enzyme, or volume of drops removed at intervals*.

Part (d) of the question explored candidates' ability to cue into information provided to apply knowledge of how enzymes work. Part (d) (i) asked candidates to suggest what process might be taking place when meat is softened with green papaya. This part of the question was not well done as candidates failed to use the information in the trend of the question to help focus on the possibilities. Similarly, in Part (d) (ii) which asked candidates to suggest why if the crushed papaya is added to the meat while cooking, that the cooking time is not shorter, many candidates did not relate the results to denaturing of the enzyme due to exposure to high temperatures.

Part (e) of the question sought to examine candidates' knowledge of the germination process taking place within a seed. Performance on this part of the question was disappointing, since this is supposedly a well-known part of the syllabus. In Part (e) (i), candidates were to indicate two ways in which water helps the process of germination. Candidates were expected to refer to its role in: *enzyme activation, transport, reaction medium, or structural material*. In Part (e) (ii), candidates were expected to identify environmental conditions for germination. It is surprising that many candidates still identify 'sunlight' as an environmental factor for germination. It is thus reiterated here that the environmental conditions necessary for germination are *air (oxygen), suitable temperature and moisture (water)*.

Part (f) of the question examined candidates' knowledge of microorganisms. Part (f) (i) asked candidates to identify microorganisms. Many candidates are unclear about what types of organisms qualify as 'microorganisms'. Candidates insist on naming the 'earthworm' as a microorganism. In Part (f) (ii), candidates were asked to identify one cycle which depends on the activities of microorganisms. Most candidates were able to name the *carbon* or *nitrogen* cycle. However, when they were asked in Part (e) (iii) to explain the importance of the microorganism in a natural cycle, many candidates were unable to indicate their role in *breakdown of organic material*, *release of nutrients* or *recycle materials*.

### Question 2

This question tested candidates' knowledge of gaseous exchange in plants and animals as exhibited in examples of freshwater snails and the pondweed. Candidates were required to predict and explain the results of an investigation that was set up with the organisms in various test tubes based on likely colour changes of a carbon dioxide indicator. Candidates were also expected to suggest what changes may have occurred in the environment to cause the sudden death of pond snails. Performance on this question was fairly good with candidates earning marks across the entire range available from 0 to 14.

In Part (a), candidates were asked to identify experimental tubes with different colour changes and explain their responses. This part of the question was fairly well done. By and large they recognised that a tube with the snails would most likely have more carbon dioxide produced by respiration, while one with the pondweed would have reduced levels of carbon dioxide because of photosynthesis.

In Part (b), candidates' were required to identify the control tube (i) and explain the purpose of wrapping one of the tubes in foil. This part of the question was fairly well done.

Part (c) asked candidates to suggest what changes may occur in the environment to cause the sudden death of the snail population in the pond. This part of the question was not at all well done. In many cases candidates provided explanations that were not related to the context of the question. Expected responses that were rarely given included: *pollution*; *reduction in oxygen supply/eutrophication*; *introduction of predators*; or *loss of food source*.

### Question 3

This question assessed candidates' knowledge of blood circulation through the heart and to the heart muscles as well as how thickening of the coronary arteries may occur. Candidates were also required to explore their knowledge of transport in plants. Generally, candidates performed within the range of expectation as shown by a mean of 9.5 out of 17 marks and a mode of 7. Candidates attained scores right across the range on this question, but the vast majority attained scores between 6 and 17.

Part (a) of the question tested candidates' knowledge of blood flow through the heart. In Part (a) (i), candidates were required to illustrate using four arrows only, the flow of blood through the heart. This part of the question was fairly well done, although candidates often confused the names of the vessels leading to and from the heart as shown in the response in Part (a) (ii). Part (a) (iii), which was fairly well done, required candidates to explain how having a 'hole in the heart' may affect its functioning when the atria contract. Candidates were expected to focus on: *mixing of oxygenated and deoxygenated blood*; *reduced efficiency in blood carrying capacity*; or *need for the heart to work harder/ strain on the heart*.

Part (b) investigated candidates' knowledge of blood transport to the heart muscles. This part of the question was well done. In Part (b) (i), candidates were to name two substances that blood transports to heart muscle cells. In Part (b) (ii), they were to identify one substance transported in the blood that could cause the walls to thicken. The expected response was *cholesterol* or *plaque*. Candidates at this level are expected to provide the more obvious response, which garners full marks. In Part (b) (iii), candidates were asked to explain how the thickening of the wall of the coronary artery affects the heart. A good response would have included aspects of: *blocking/reducing flow of blood; reduction of size of lumen; inadequacy of supply of nutrients to heart; inability to deliver adequate blood supply; resulting in a heart attack/infarction*.

Part (c) examined candidates' knowledge of transport in plants. This part of the question was fairly well done. Candidates were generally able to identify the xylem and phloem. However, far too many candidates confused what was transported by the different tissues. Some felt that xylem transported both 'water and food' or that phloem transported 'food and nutrients'. It should be noted that the xylem transports *water* and *mineral salts* and that the phloem transports *manufactured food/sugars*.

#### Question 4

This question examined candidates' knowledge of the processes of meiosis and mitosis, as well as cloning. It also tested candidates' knowledge of the development of the ovule into the seed. Candidate performance on this question was disappointing, although there was general familiarity with the topics, and candidates were able to gain marks across most of the spectrum from 1 – 14 out of 16. A few candidates were unable to gain any marks at all. The mode was 5.

In Part (a), candidates were to distinguish between the processes of meiosis and mitosis. In Part (a) (i), candidates were required to distinguish between diagrams illustrating the differences in the processes; in Part (a) (ii), they were to identify differences between the processes and then name specific locations in plants where these processes occurred in Part (iii); then provide reasons why both types of cell division are important in the plant for Part (iv). Although this topic was familiar to the candidates they often interchanged the processes and this shows the need to emphasize the differences between these types of cell division. Candidates should note that *meiosis produces 4 daughter cells per division compared with 2 for mitosis; meiosis results in reduction division while the genetic number is maintained in mitosis; meiosis produces non-identical gametes while mitosis produces identical daughter cells*. Candidates often failed to identify that mitosis occurred in the *meristems* found in the *root tip* and *shoot tip* or the *cambium*, while meiosis produced *pollen in the anthers* and *ova in the ovaries*. In responding to Part (a) (iv), candidates were to indicate one of the following for the importance of meiosis: *for maintaining the diploid number of successive generations; introduction of variations into the species; better adaptability to changing environmental conditions; gamete production/halving the chromosomes number*. They were to consider one of the following for the importance of mitosis: *growth/producing similar types of cells; repairs of tissues; rapid production of clones/offspring in favourable conditions; taking advantage of favourable conditions*. Part (b) of the question was fairly well done. It asked candidates about cloning and the possible advantage and disadvantage. Candidates were initially required to identify the process of *cloning* from a written description provided in Part (b) (i). They were then required in Part (b) (ii) to suggest one advantage and one disadvantage of the process. Candidates were expected to select from these advantages: *retain/pass favourable characteristics*; and from the following disadvantages: *long term effect not fully known; aging of clone may be faster; attempt to clone humans*.

Part (c) dealt with candidates' knowledge of the development and structure of the seed. This part of the question was very badly done. More than half the candidate population did not know that the *ovule* developed into the *seed*, which was the expected response for Part (c) (i). As much as ninety percent of the candidate population could not give two features of the seed which was required in response to Part (c) (ii). Candidates were expected to identify features such as: *the seed bears a single scar; possesses cotyledons, contains the embryo, found within the fruit* and so on.

#### Question 5

This question tested candidates' knowledge of the nitrogen cycle and the relationships, mutualism and commensalisms. Candidates were able to gain marks across the entire spectrum from 1 to 13. Performance on this question was reasonable although it was expected that candidates would be more generally familiar with the processes involved in the nitrogen cycle. Candidates seemed to most easily access the marks in the parts of the question that dealt with mutualism and commensalism.

Part (a) was presented in the form of a stylized nitrogen cycle from which the candidates' knowledge of the topic was examined. Part (a) (i) of the question asked candidates to name the processes carried out by bacteria that occur at identified points on the diagram. Candidates performed very poorly on this part of the question. Some seemed unfamiliar with the processes and others, who were familiar with the terminology, were confused by the process. Candidates were expected to identify in sequence: *nitrogen-fixation, denitrification, decomposition and nitrification*. Part (a) (ii) asked candidates to explain how nitrates from the soil become protein in plants and animals. Candidates were expected to refer to: *plants absorb nitrates from the soil; nitrates used to synthesized proteins in the plants; plants eaten by herbivores; herbivores by carnivores; plant proteins/amino acids used by animals to make animal proteins*. This was fairly well done, although many candidates did not recognise a sequence to the process of incorporating nitrogenous compounds by plants before being accessed by animals through feeding. Part (a) (iii) required candidates to explain why the relationship between legumes and the bacteria in their root nodule was considered mutualistic. Candidates needed to explain the benefits derived by both organisms from the relationship and sometimes this was not done. Candidate performance on this part of the question was fair. They were expected to include in their responses: *both organisms benefit from the relationship – the legumes obtain nitrates from the activity of the bacteria; legumes can thus grow in soils depleted of nitrogen; bacteria obtain in the relationship some nutrients/shelter*.

Part (b), which asked candidates to identify types of relationships other than mutualism, was well done. Candidates were expected to refer to: *commensalism, parasitism; predator/prey relationships* and were often able to provide appropriate examples.

### PAPER 03 – Extended Essay

Candidates' performance on this paper was consistent with their performance in January 2007. Candidates demonstrated a continuing ability to write at length about biological events, principles and concepts. However, sometimes candidates missed key words in the questions and provided answers which were off the point. It is thus reiterated that candidates should be advised that *the reading time should be used to read through each question carefully, highlighting key words on which the questions hinge, so that they would be less likely to misread and misinterpret questions. **The reading time should also be used to plan their responses so that they are more likely to stick to the relevant topics.*** It is clear that much time is spent on teaching and learning the content of the syllabus. However, more attention needs to be paid to developing important examination techniques which will allow candidates to make the best use of what they know.

#### Question 1

Candidates selected this question more frequently than they selected its counterpart, Question 2. This question required knowledge of the excretory functions of the body and the structure of a uriniferous tubule. In addition, this question tested candidates' knowledge of the effects on the liver of alcohol abuse, as well as their general knowledge of drug abuse. Candidate performance on this question was unexpectedly low, with the vast majority of scores within the lower half of the mark range.

Part (a) examined candidates' knowledge of excretion. In Part (a) (i), candidates were asked to identify two substances produced by the body that can attain toxic levels. Most candidates knew of at least one substance. Many candidates were not specific enough and included 'nitrogenous waste' instead of *urea*. In Part (a) (ii), candidates were to explain with the aid of a diagram how the kidney tubule is able to reduce toxic levels of a substance in the body to harmless levels. Candidates generally knew how urine is produced, but were often unable to relate the production of urine to reduction of the levels of urea in the body. They often failed to include in their responses: *continual filtration; toxic substance in filtrate, the removal of a little more of the toxic substance with each volume of blood filtered in the kidney.* Many diagrams were also poorly drawn.

Part (b) dealt with candidates' understanding of the damage that can be done to the liver through alcohol abuse and the impact on the functioning of the liver. Most candidates were able to gain some of the marks in this section. However, candidates needed to convey that: *alcohol abuse can lead liver damage/cirrhosis; build up of toxicity; poisoning/death, in addition to malfunction and improper metabolism of a range of substances.* Several candidates provided specific examples of liver functions for example, 'production of bile', 'conversion of glucose to glycogen' and deamination of protein' but did not make the link to damage to the liver.

Part (c) examined candidates' knowledge of drug abuse. In Part (c) (i), candidates were to suggest reasons for increased drug abuse. This part of the question was fairly well done. Candidates were able to provide expected responses including: *availability, accessibility, thrill/pleasure seeking and peer pressure*. In Part (c) (ii), they were required to suggest ways in which prescription drugs might be abused, and to suggest likely long-term effects. Candidates performed fairly well on this part of the question, although they failed to include the wide range of possible responses and sometimes their responses tended to be somewhat vague. They were expected to refer to: *not taking the full dose of prescription; stop taking drugs before course is finished; taking old/ leftover drugs; too frequent administering of drugs*. Long-term effects expected to be referenced included: *resistance by user to drug; loss of effectiveness; pathogens develop resistance; new strains become more virulent; more difficult to treat*. Too many candidates still made the mistake of saying that the pathogen will become 'immune' rather than *resistant*.

## Question 2

The question required a description of the stages in the life history of an insect vector, reasons for continued outbreaks of vector borne diseases and methods of protecting the body from contracting infectious diseases. Candidate performance was surprisingly weak as they seemed challenged by many parts of the question. Scores ranged from 1 to 14 with only one candidate gaining above 14.

In Part (a) (i), candidates were asked to describe, with the aid of a diagram, the stages in the life history of a named insect vector of disease and in (a) (ii) to suggest why vector borne diseases still occur in spite of knowing the life histories of the vector. Candidates performed poorly on Part (a) (i). They showed a surprising lack of accurate knowledge of the life history of an insect vector. They interchanged 'larva' and 'pupa' and used terms like 'baby mosquito' to describe the *larva* and *pupa*; *pupa* became 'pupil' and *imago* became 'embryo'; and incorrect descriptions were given to the pupal and larval stages. Very few candidates gave the expected responses such as: *larva as the feeding and growing stage; pupa as the stage of internal development and re-organisation; the adult as the reproductive stage or stage for distribution of species since they have wings*. For Part (a) (ii), candidates gave better responses. They focused on *improper hygienic practices and lack of education*. However, their responses could have included other suggestions such as: *other human activities such as travel; pathogens mutate; unavailability of medicines to the poor; vectors not eradicated; knowledge of life history helps to control spread, not cure disease*.

In Part (b) (i), candidates were asked to explain the principles involved in taking a course of vaccines. This part of the question was not well done. Even though a 'course of vaccines' was explained in the stem as "more than one dose over time", many candidates gave responses that did not address the question, stating 'some vaccines are taken annually', '... every five years' or '... once in a life time'. When the question was correctly interpreted, candidates displayed fair knowledge of the principles involved in taking vaccines. They included in their responses some of the following: *antibody production stimulated by antigen; small dose of weakened antigen initially; for subsequent infection, antibodies already present/memory; rapid response subsequently; more antibodies made*. In Part (b) (ii), candidates were required to suggest why the principles of vaccination do not work for all infectious diseases. This part of the question was not well done, principally because of the loose use of biological terminology. Candidates must understand that they cannot be rewarded when biological jargon is used incorrectly. In particular, the terms 'adapt' and 'immune' were inappropriately used in the majority of cases. Some candidates claimed that 'the influenza virus adapted to the person', while others said 'the person was immune to influenza'. Candidates were expected to frame their responses around the following ideas: *viral antigens may change frequently; rapid mutation; new antibodies required each time infection occurs; bacterial infections are best treated with antibiotics*.



### Question 3

The question tested candidates' knowledge of the structure and function of the human female reproductive system and birth control methods, as well as their views on the control of the size of human populations. This was by far the more popular of the questions in Section B of the paper. Candidate performance on this question was quite satisfactory. Marks were obtained in the range from 2 to 20. No candidate obtained a score of 0 or 1 in this question and a number obtained full marks. The mode was high at 13.

Part (a) asked candidates to (i) describe the structure of the human female reproductive system, and (ii) explain how the reproductive system was suited for its function in reproduction. Most candidates were able to draw a reasonable diagram of the female reproductive system, although a very large number had no idea of the spelling of the various parts. Terms such as 'ovary', 'ovum' and 'ovule' were used interchangeably in Part (a) (i). In Part (a) (ii), instead of explaining how the system was suited for its functions, several candidates described the process of sexual reproduction. Candidates were expected to construct their responses to include: *ovaries produce eggs/hormones; oviduct/fallopian tube transports the egg/site of fertilisation; uterus houses the embryo/protects the embryo; cervix can dilate to expel the baby; vagina is the birth canal/accepts the penis.*

Part (b) of the question explored candidates' knowledge of contraceptive methods. In Part (b) (i), they were asked to explain how tubal ligation could prevent pregnancy without stopping the monthly period. This question was well done. Most candidates gave an appropriate explanation, although some candidates thought that tubal ligation would prevent the development of the egg. A good response was:

Although tubal ligation prevented the sperm from reaching the egg and preventing fertilisation, the monthly period is controlled by hormones which travel in the blood so this process would not be affected.

Part (b) (ii) asked for three other birth control methods. This was very well done. Most candidates were aware of at least three additional methods of birth control.

Part (c) of this question focused on the control of the human population. In Part (c) candidates were asked to (i) suggest reasons why control of the human population is necessary, and (ii) explain whether or not government should decide on the number of children a couple should have. Candidate performance on this part of the question was fair. In Part (c) (i), many candidates were able to provide suitable reasons for controlling the size of the human population. Candidates were expected to include in their responses some of the following: *humans depend on natural resources; there is a limit to these resources; population must not outstrip resources; human population subject to the same limitations as other animal populations.* A good response was:

There are limited resources. More people may bring more pollution and there would be need to build more houses which would mean cutting down more trees.

In Part (c) (ii), candidates were rewarded for answering, either in the affirmative or negative, once the response was appropriately supported. Candidate performance on this question was good. Candidates responding in the affirmative were expected to refer to: *limited resources; government provision of social amenities; government's responsibility to protect the environment.* Candidates responding in the negative were expected to refer to: *size of family a matter of personal choice; erosion of individual rights; possible upset of overall gender balance; religious/cultural belief/traditions.*

#### Question 4

Only one in approximately ten candidates selected this question. The question examined candidates' knowledge of the structure of a dicotyledonous seed and the role of its constituents in growth and development. Candidates' were also asked to explain the roles of selected hormones in human growth and development and to predict results of a genetic cross. With fewer than sixty candidates attempting this question the statistics may have little value. However, performance on this question was satisfactory, with a mean of approximately 8. Scores were achieved across the spectrum from 0 to 20 and they were bimodal at 4 and 12.

Part (a) asked candidates to describe, with the aid of a diagram, the internal structure of a dicotyledonous seed. This part of the question was fairly well done, although several candidates included external structures such as 'testa' and 'scar'. Some drew the internal structure of a leaf. In Part (a) (ii), candidates were asked to explain the role of the parts of the dicotyledonous seed in growth and development. This part was fairly well done. Candidates were expected to include in their responses: *the cotyledons – provided food, were the site of conversion of stored food and translocation to the embryo, site of enzyme activity; embryo/plumule and radicle formed the seedling.*

Part (b) sought to explore candidates' knowledge and understanding of the role of hormones in growth and development in animals. In Part (b) (i), candidates had to identify two hormones involved in the process. Most candidates were able to give two examples, but some candidates gave the organ of production rather than the hormones and failed to gain the marks allotted. In Part (b) (ii), candidates were to suggest why there should be concern about the diet of young children which included products from animals treated with hormones. This part of the question was not at all well done. Candidates failed to relate the possible absorption of hormones from food to growth and development issues in young children. Instead, they tended to focus on dietary issues like the lack of nutrients and obesity. Candidates were expected to include in their description a coherent account based on: *excessive hormones stimulate development; secondary sexual characteristics develop earlier than normal; long-term ill effects.* A good response to this part of the question was:

Excess hormones in a young child can lead to certain adolescence features developing before they are supposed to.

It can also affect the long-term health of a young child because of too rapid growth and development.

Part (c) asked candidates to explain, with the use of genetic diagrams, how it was possible for a goat breeder to obtain large offspring. The majority of candidates attempting this question used symbols inappropriately. They did not seem to understand that the desired offspring was large and reference was to a simple monohybrid cross. The symbols were selected for a large ram and high reproducing female rather than for large ram and normal or small female. Some thought that large size was sex-linked and others lost marks as they skipped steps in the genetic process, for example, they went from parents to  $F_1$  generation without showing gametes. Where candidates did not make these errors they were able to gain full marks for this part of the question. A good response was:

L – dominant (large)

l – recessive (small)



The large male would have a genotype LL. If the female has a genotype ll, then the cross in the genetic diagram shows the offspring genotype.

	<b>Female</b>	<b>l</b>	<b>l</b>
<b>Male</b>			
<b>L</b>		Ll	Ll
<b>L</b>		Ll	Ll

Ll – all the goats would be large since L is dominant over l. The desired results are obtained.

### Question 5

This was by far the more popular question of the pair in Section C, attracting almost two-thirds of the candidate population. The question required knowledge of decomposers and their role in the carbon cycle. They were also expected to use knowledge of occurrences in the carbon cycle to account for global warming and the possible negative and positive effects of this phenomenon. Candidate performance on this question was fair. The mean for the question was approximately 5 and the mode was 7. Candidates had great difficulty accessing marks in the upper ranges with no candidates scoring more than 15 marks.

In Part (a) of the question candidates were required to define decomposers, explain their role in the carbon cycle and explain characteristics they possess to fulfill their role. Candidate performance on this part of the question was fair. They were generally able to provide a definition of 'decomposers' (Part (a) (i)), but few were able to explain their role and adaptations. In Part (a) (ii), candidates were expected to include in their responses the following ideas: *decomposers recycle nutrients from dead bodies/ organic matter/ waste/ urine; carbon compounds absorbed/ incorporated by organism; carbon dioxide returned to the atmosphere during respiration; carbon in waste materials recycled.* In Part (a) (iii), candidates still made the error of identifying earthworms as decomposers. It is again reiterated that decomposers are *bacteria* and *fungi*. The characteristics that these organisms possess that make them effective decomposers are as follows: *absence of chlorophyll; inability to manufacture food; they secrete enzymes; they digest organic matter to obtain nutrients; many capable of anaerobic respiration; breakdown carbohydrates in low oxygen conditions.*

Part (b) asked candidates to explore their knowledge of the carbon cycle in relation to various phenomena. In (b) (i), candidates were asked about the benefits of greenhouse conditions to plants. Candidates did not perform well on this part of the question. They were expected to use their knowledge of what occurs in a greenhouse that cause plants to flourish, which should relate to conditions that would promote growth in plants. They were thus expected to include in their response ideas such as: *high temperature increases rate of photosynthesis; high humidity restricts transpiration; starch is formed faster/more food available; plants thrive*. In Part (b) (ii), candidates had to suggest reasons why global warming is not desirable for animals. This part of the question was also not well done. Candidates were often only able to access half the available marks. They were expected to consider that *elevated temperatures increase the rate of water loss/desiccation of small invertebrates; affected the environment, for example, destruction of habitats/melt ice caps, alter periods of rainfall/drought; cause natural disasters – hurricanes, tsunamis, tornadoes, flooding; lead to increasing poverty, hunger, loss of life*. A good response to this part of the question was:

... when global warming occurs the temperatures can become too high for animals because they are not built to adapt quickly to major climate change. There is also the destruction of their habitat, such as, the melting polar ice caps that reduce the habitats of polar bears and threaten their food supply.

Part (b) (iii) asked candidates to suggest one way in which global warming might be advantageous. Many candidates were able to provide a reasonable response, including: *warming of cold countries making them more temperate; increase in crop yield in some countries*. A well thought out response was:

... winter might no longer be very cold or even exist allowing plants to grow all year through without problems of shortage of supply of food.

### Question 6

This question required knowledge of the importance of wetlands and the negative impact of human activity on them. Candidate performance on this question was fair with a mean of approximately 6 and a mode of 6, although few candidates obtained the higher scores and no one got full marks.

Part (a) investigated candidates' ability to apply their general knowledge of ecology to a particular habitat. In part (a) (i), they were asked to give reasons why wetland ecosystems are of great importance. Candidate performance on this part of the question was fair. Candidates showed little knowledge of the importance of wetlands, which should be of concern to them especially as Biology students. Some even interpreted the terminology as 'wet land' and consequently did not address wetland issues. A number mentioned wetlands and tourist attractions. However, in addition, they were expected to include among their suggestions the following concepts: *wetlands are nurseries for fish, crustaceans; habitats for birds; reduce pollution through treatment of effluent; reduce damage to coastlines during hurricanes/storms; protect against loss of life*. In Part (a) (ii), candidates were to suggest ways in which human activity could affect a wetland ecosystem. Candidates performed fairly well on this part of the question. They recognised the potential for pollution and destruction of the wetland from a range of human activities. Candidates were expected to include the following ideas in their responses *housing/commercial developments; road/highway construction; burning mangroves for coal; dumping non-biodegradable waste material; hunting/killing wildlife/reducing biodiversity*.

In Part (b) (i), candidates were required to suggest reasons why indiscriminate garbage disposal should be discouraged. Performance on this part of the question was weak. Candidates generally seemed to believe that the garbage itself cause disease and bacteria. It should be noted that to gain the available marks candidates had to make the link with the garbage harboring disease vectors. Candidates were expected to frame their responses using ideas like: *garbage attracts vectors of disease; provides food for disease-causing organisms, for example, houseflies; attract scavengers; are unattractive/bad for image of the community/country*. In Part (b) (ii), candidates were asked to suggest means, other than posting signs, to encourage proper garbage disposal. This part of the question was well done. Candidates considered factors such as ‘education’, ‘increased numbers of garbage bins in prominent places’, ‘charging fines for littering’.

Part (c) required candidates to present an argument, from the perspective of an environmentalist, against the use of inorganic fertilisers. This part of the question was not very well done. Candidates simply indicated that inorganic fertilisers were ‘harmful’ but did not say in what ways and to which organisms. Candidates were expected to include in their responses: *these fertilisers easily leach into water; contribute to death of aquatic life; affect the pH of the soil/waterways; increase nutrients in water, leading to eutrophication; causes algal bloom which reduces availability of oxygen to other organisms; facilitates soil erosion*.

### **PAPER 042 – Alternative to the SBA**

This paper assessed all the practical skills required of biology students. Candidates continue to display weak practical skills, especially in aspects of planning and designing including manipulating and describing methods of experiments and in drawing conclusions from data. It is thus re-iterated that these observations suggest that teaching for developing practical skills *must include actual experimenting and investigating scientific phenomena, discussions, explanations and rationalizing of procedures and outcomes on the part of students* so that they become capable of developing and manipulating experiments and experimental data on their own.

#### Question 1

This question tested a range of candidates’ experimental skills including classifying organisms (from drawings), presenting data, and investigating organisms in a specific habitat. Candidates were also required to make a drawing of a fish gill from a photograph and relate the structure of a gill to its function. Candidate performance on this question was reasonable although very few attained top scores. Candidates displayed weak skills in classifying organisms and were often unable to describe a method for investigating organisms in leaf litter. The mean for this question was approximately 11 out of 27 marks available, while the mode was also 11.

Part (a) required candidates to demonstrate the skills of Observing/Recording/ Reporting, Measuring and aspects of Planning and Designing. In Part (a) (i), candidates were to identify three characteristics that they observed in drawings of six organisms that could be used to classify them. This question was generally well done by candidates, although their spelling and or interpretation of *antennae* were at times quite atrocious. They referred to 'antlers' 'anthenas', 'antenas' and a host of other variations. Part (a) (ii) asked candidates to construct a key, table or chart to show how the characteristics identified would distinguish among the organisms. This question was fairly well done. Several candidates were able to organise a table to distinguish the organisms. Part (a) (iii) was not very well done. Too many candidates thought that they could use a quadrat to investigate the number and types of organisms in a leaf litter habitat. Candidates were expected to describe the use of: *traps/bottles, Tullgren funnel* or some *means of sifting through the leaf litter*. They were also to include in the description of the method of their investigation *counts/ estimates of per unit area; identification/ classification procedure; and repeats*. Few candidates were able to give a precaution in carrying out the investigation, required in Part (a) (iv), but could provide at least one safety precaution for which they were rewarded. In Part (a) (v), candidates were to construct a table to show how data collected by the method described in (a) (iii) would be recorded. This was a very poorly done part of the question. Candidates failed to gain what could be described as easy marks. They were to include in their table the following characteristics which are the normal requirements of a table for recording field data: *appropriate headings, appropriate columns that include one for numbers; neatly boxed with appropriate title*. Part (a) (vi) was fairly well done. Several candidates gained full marks in this section as they were able to provide sound reasons for the leaf litter to be considered a good habitat for the organisms identified in this question. Where candidates were unable to gain the marks in this section they seemed not to realise that there were biological reasons for the organisms to be attracted to the habitat and it was not simply because they 'liked' the environment. Candidates were expected to indicate that the *leaf litter consists of decaying leaves which provided a ready food source for small herbivores; created a favourable micro-climate; reduced desiccation; provided shelter from predators*.

Part (b) (i) of the question, which required drawing of a fish gill from a photograph of a dissected fish head and knowledge of the structure and function of the gill, was not very well done. Candidates generally ignored the rules of drawing including guidelines for clarity and accuracy and thus failed to gain the allotted marks. Part (b) (ii), which required the magnification of the drawing, was also not well done. There were two problems, the first, in calculating the magnification (some candidates guessed as much as 1000 times) and the second, in representing the magnification. The conventions for these must be observed to gain the mark allotted. Note that the magnification must be written with 'x' in front of the value. Part (b) (iii) asked candidates to explain how the structure of the gill is suited to its function. This was poorly done. Candidates held a number of misconceptions about the breathing apparatus of the fish and how breathing takes place. They feel that the 'fish takes in air', that 'the operculum is the breathing apparatus' and that the 'gills filter the water'.

Candidates were expected to include in their responses that: finely divided filaments increase surface area and absorption; copious blood supply for efficient uptake of oxygen; gill rakers which are sturdy, form barrier for protection of delicate filaments; and secretion of mucous for trapping particles.

## Question 2

This question tested the candidates' ability to use graph paper to determine the areas of two different types of leaves, explain the importance of leaf area and how a plant might compensate for having leaves with small areas. Candidate performance on this question was good with a mean score of approximately 10 out of a total of 17 and a mode of 9.

In Part (a) (i), candidates were required to draw the two leaves with which they were provided on the graph paper. This question was fairly well done with most candidates obtaining at least half the available marks. It was heartening that few candidates shaded their drawings although there were some obvious challenges to the candidates. Too often their drawings showed untidy lines of uneven thickness; no magnification included; leaf stalk not drawn as directed and no distinguishing features seen between the two specimens. In Part (b), candidates were to identify three differences observed between Specimen A and Specimen B. Candidates scored poorly on this part of the question. They seemed not to know the external structure of the leaf. They seemed unfamiliar with terms like *apex*, *margin*, *leaf stalk/petiole*. Candidates did not recognise that while Specimen A had a network of veins, Specimen B had parallel veins. Many claimed that Specimen B had no veins. Also, when asked to compare, candidates tended to give a feature in one leaf and failed to say what obtained in the other leaf for that feature. It is reiterated here that a comparison must be made of the same feature in the two organisms being compared to qualify as a comparison. Part (c) was very badly done. Candidates were asked to calculate the leaf area of the two leaves. Many candidates did not recognise that the reason why they were asked to draw the leaf on the graph paper was to facilitate the estimation of leaf area, and all they were required to do was to count the number of square centimetres, compensating for the irregular shape of the leaves. Some candidates measured the length of the leaf down to the tip of the petiole and multiplied by the width of the lamina at its widest part. Other candidates counted the millimetre square which would have taken an inordinately long time and was not necessary. In Part (d) (i), candidates were asked to explain the importance of leaf area to the plant. This part of the question was well done. Responses that failed to gain full marks were often those that did not link the functions of the leaf to the area of the leaf as required by the question. A good response was:

The larger the leaf area, the more surface of the leaf is exposed to air and sunlight, allowing maximum absorption of sunlight and carbon dioxide for photosynthesis, making more food.

In Part (d) (ii), candidates were asked how a plant might compensate for having small leaves. This part was also well done. However, some candidates appeared to have lost marks because they did not understand the term 'compensate', while a number of others referred to 'reduction of transpiration rate' and 'development of longer roots to obtain water', and some even made wild statements like the 'plant obtains food from the soil'. Good responses included: *by producing numerous leaves, growing taller to maximize exposure of leaves to sunlight; having more chloroplasts; obtaining food from other plants, that is, becoming parasitic.*

## Question 3

This question tested the candidates' ability to represent data from a field study on water loss in two plant species. Candidate performance on this question was good although no candidate obtained full marks. The mean was approximately 10 out of 16 and the mode was 10.

Part (a) of the question required candidates to draw a pair of graphs to represent data collected on water loss in two plant species. Candidates performed fairly well on this question and generally plotted the points correctly, although a number of them made several errors. Errors observed included: *use of incorrect axes, absence of a title, untidiness, absence of a key.*

In Part (b), candidates were to identify sources of error in the investigation. This part was fairly well done. A good response was: *error in measuring the plant due to faulty scale; error in timing the hourly intervals ...*

Part (c) required candidates to explain the differences observed in water loss in the two plant species. Candidate performance on this question was only fair. Candidates were expected to determine that Species Q lost water faster than Species P and this might relate to the suitability of the species to different environmental conditions. Good responses were as follows:

Species P might have been a plant adapted to an environment containing little water supply while Species Q might have been from an environment with an abundant supply of water, therefore it is not adapted for water loss.

Q loses more water than P because maybe Q has more stomata or the stomata of Q may be larger. Species Q loses more water than P, therefore the transpiration rate level in Q is more than in P.

Part (d) required that candidates illustrate, using a diagram, how the apparatus provided (a string, weighing apparatus, a plant and a sheet of clear plastic) could be used to collect the data provided in the table. Apart from poor drawing skills already discussed in relation to Questions 1 and 2, few candidates were able to correctly illustrate the arrangement of the apparatus. The plant was often drawn with the part above the soil wrapped in the sheet of plastic and the plastic with water positioned on the scale; and the string in the wrong position. Candidates were expected to show the plant positioned on the scale and the *plastic wrapped around the pot and tied with the string at the base of the plant, just above the soil.*

**CARIBBEAN EXAMINATIONS COUNCIL**

**REPORT ON CANDIDATES' WORK IN THE  
SECONDARY EDUCATION CERTIFICATE EXAMINATION**

**MAY/JUNE 2008**

**BIOLOGY**

## BIOLOGY

MAY/JUNE 2008

### GENERAL COMMENTS

The June 2008 examination in Biology at the General Proficiency level was the 33<sup>rd</sup> sitting of this subject conducted by CXC. Biology continues to be offered at both the January and June sittings of the examinations. The biology examination is one of the more popular of the single sciences offered by the CXC at the CSEC level and assessed the performance of approximately 14 000 candidates this year. The examination comprises three papers: **Paper 01 – Multiple Choice; Paper 02 – Structured/Extended Essay paper; and Paper 03, the School-Based Assessment (SBA)**. This examination marks the first sitting in which the structured and extended essay papers are combined and all questions are compulsory.

The overall performance of candidates this year is better than that of last year's even though there was a major change in the structure of the examination, including the elimination of choice of essay questions on the paper. Candidates were able to score across the range of marks for almost all questions. However, far too many demonstrated limited knowledge of fundamental biological concepts and principles and basic knowledge of biological phenomena. Generally, candidates performed inadequately on questions that required specific knowledge of familiar biological concepts, principles and processes. Candidates often indicate that they 'know' the material, but cannot recall the names and definitions. They are still unable to adequately display the skills they are supposed to acquire in pursuing practical work. These comments relate to teaching of the subject matter and calls for students having more opportunity to express for themselves the concepts, principles and processes – writing these down and checking for accuracy as well as for engaging in practical activity and not merely writing up experiments in note books. Further, there is insufficient attention paid to several suggestions which the Biology examiners have repeatedly made over the past years. These comments take on more meaning with the new format of the Biology examination that has eliminated choice. Particular attention must be paid to the comments reiterated below in preparing candidates, *if the desired improvement in performance is to be realized and sustained*. These comments relate both to test-taking techniques and means of addressing the content of questions:

- Teachers should remind their students that there is more to taking an examination than memorizing the content. When preparing students for an examination time should be spent practising *how to interpret* and answer questions clearly, concisely and to the point.
- Candidates also waste time providing information that is irrelevant to the question. This gains them no marks. This is particularly important for the extended essay component of the paper. Candidates ought to make better use of the time allotted for reading through the paper, selecting their questions and planning their responses *before* starting to write.
- Too many candidates still do not read questions well. They should be advised to take special note of the cues given in the questions and underline key words to draw attention to what the question requires. When the question asks for two items many candidates give one and lose marks unnecessarily through apparent carelessness.



- Also, many candidates have the tendency to select an obscure partially correct response instead of the obvious more familiar response to questions. This relates to both question writing technique and knowledge of the subject matter. It should be noted that more marks are awarded for the obvious responses to the questions.
- In papers where limited spaces are provided for short answers, candidates insist on repeating the questions asked, leaving insufficient room for responses and then writing their responses in the margins. This wastes valuable writing time.
- The first three questions required candidates to write their responses in spaces provided. However, several candidates re-wrote the questions in the extended response booklets instead. Apart from wasting time and running the risk of losing marks, this also shows the difficulty some students have in following examination instructions. The inability to follow instructions and guidelines is often disadvantageous to their performance.
- Candidates should also use the question numbering as a guide to link the different parts of the question. They should note that the numbering changes when there is a change in concept or context. They should also make every attempt to use the information given in the various parts of a question to help focus the context and content of their responses.
- Biological jargon should be used where appropriate and **spelling** of biological terms must be correct. Spelling of common biological terms continues to be atrocious. It is not possible to award marks for incorrectly spelt terms where they actually mean something different. Candidates far too often seemed unfamiliar with common terms used in Biology, for example, “distinguish”, “precaution”, “factor”, “implications” or “types”. Teachers should direct their students to the glossary of terms available in the CSEC Biology syllabus.

It should be noted that candidates at this level are expected to demonstrate understanding of fundamental principles and concepts such as *the relationship of structure to function; the relationship of living organisms to their environment; the cell as the fundamental unit of living organisms; genetics and variation and their role in perpetuating species, and the impact of disease on living organisms including social and economic effects on humans.* The Biology Team suggests that teachers should use more constructivist approaches in the teaching of Biology in which their students would be more involved in explaining their notions, clarifying the content and be more fully engaged in problem-solving activities.

Every effort must be made to encourage and facilitate the use of appropriate biological jargon including the correct spelling of terms. Candidates can lose marks for incorrect spelling as the badly spelt term might take on new meaning.

Some examples of biological terminology with which candidates were not familiar include:

- Annotated
- Adaptations
- Implications
- Biological control

- Genetic engineering
- Resistance
- Immunity

### **DETAILED COMMENTS**

#### **PAPER 01 – Multiple Choice**

Paper 01, as is customary, consisted of 60 multiple-choice items. Performance on this paper was quite similar to that of last year's. The mean for the paper was 61% compared with 62% last year.

Some of the topics that were *most* problematic for candidates were:

- Role of bacteria in the nitrogen cycle
- Respiration experiments
- Excretion in plants
- Water conservation in plants
- Identifying variables in an investigation
- Reflex arc and reflex action
- Bones – vertebrae and their functions
- Function of the skin in humans
- Reproduction in *Amoeba*
- Aspects of growth in plants and animals for example, role of auxins
- Menstrual cycle
- Distinction between natural and artificial selection
- Metabolic rate and effect on body temperature

#### **PAPER 02 – Structured and Extended Essays**

Paper 02 consisted of six questions, three of which were in the structured response format and three in the extended essay format. This paper tested all profile skill areas identified in the Biology syllabus. All questions were compulsory. Candidate performance on this paper was better than expected in that candidates were able to gain marks across the range for all questions and the mean for almost all the questions were quite close to the mid-point of the range. The mean overall score was 45 percent.

Since candidates were able to attain marks across the allotted range for all questions, it is evident that all marks on the paper were available. However, for more candidates to give their best performance attention must be paid to observations and suggestions the Biology examiners have repeatedly made. Observations and suggestions relate primarily to examination techniques which candidates should follow when writing this paper. In particular, candidate attention is drawn to the use of the stimulus material in responding to the questions and the guidance provided by the spaces allotted to each question where necessary. Candidates must note that they are not required to repeat the questions to begin their responses for the first three questions on the paper. Candidates also continue to display weak practical skills especially in planning and designing, manipulating and describing methods of experiments and in drawing conclusions from data. These observations suggest that teaching for developing practical skills must include discussions, explanations and rationalizing of procedures and outcomes on the part of students so that they become capable of developing and manipulating experiments and experimental data on their own. Simply having students write up experiments without orally communicating what they are doing and providing appropriate explanations for occurrences squanders the opportunity practicals provide for teaching and learning.

### Question 1

This question dealt with an investigation of the water retention properties of two soil types, classification of soil organisms, some of their adaptations for feeding and also ways of investigating soil populations. Candidates were also required to demonstrate planning and designing skills, knowledge of data collection methods and ways of representing data as well as their ability to interpret data.

Candidate performance on this question was quite good. Most sections of the question was well done by the candidates. The mean was approximately 14 out of 25 and the mode 16 with just over the majority of candidates scoring more than half the marks allotted to the question.

Part (a) of the question required candidates to compare pie charts from an investigation of two soil samples. Candidates were required in Part (a) (i) to calculate the percentage of air in one of the samples, and in Part (a) (ii) to account for the difference in the proportion of air in the samples. These parts of the question were fairly well done by the candidates. The majority were able to calculate the percentage of air and provide a rationale for the differences based on the additional information that they derived. A good answer to Part (a) (ii) was:

There is more air in Sample B since there is less clay (more air spaces), and there is less air in Sample A since there is more clay (less air spaces).

In Part (b) candidates were required to explore water retention properties in the two soil samples by reading the volumes in the measuring cylinders in responding to Part (b) (i) and identifying the cylinder that showed drainage of a selected soil sample in Part (b) (ii). These parts of the question were fairly well done although many candidates omitted the units in recording the volumes in Part (b) (i). Part (b) (iii), which asked candidates to estimate the volume of water retained by each soil sample, was also fairly well done. Part (iv), which asked candidates to identify a source of error in the investigation of the soil samples was well done by the better performing candidates. Candidates were expected to select responses from a range that included: *measuring of the volume of water/soil; drainage time; reading measuring cylinder* and so on. A noteworthy candidate response was:

One sample of soil may already have water so that the calculation of the water retained may be made in error.

Part (b) (v) asked candidates to explain the importance of investigating water retention properties of soil. This part of the question was reasonably well done. Candidates were expected to make reference to: *the provision of plants with water held in the soil; different soils hold different amounts of water; can match soil type with plants that require different amounts of water*. A good response to this question read:

So that one will know which soils are suitable for the growing of plants depending on their needs. One will know about the soil and so be able to take suitable measures to better equip them for a variety of needs, for example, low water retention causes leaching so one can add humus.

Candidates performed reasonably well on Part (c) of the question that assessed candidates' knowledge about investigating soil organisms. In Part (c) (i), candidates were asked to identify a couple of features that they observed on the diagrams of soil organisms presented in Figure 3. In Part (c) (ii), they were to identify a group of soil organisms that is important in recycling soil nutrients. Far too many candidates identified earthworms as organisms that recycle nutrients. Thus, the expected response was *bacteria* or *fungi*. Candidates were generally able to earn the marks allocated to Part (c) (iii), which asked for reasons why certain of the organisms were to be found under stones or leaf litter. Candidates generally recognised that this would allow for: *protection from predators; prevention of desiccation; not adapted for dry conditions, need moist habitat*. Part (c) (iv) was one of the most badly done sections of the question and shows quite clearly the lack of attention paid to practical skill in Biology. The majority of candidates had little clue about how to carry out an investigation of soil organisms, incorrectly making reference to the use of quadrats along with the absence of evidence of data collection and recording methods. Candidates were expected to suggest the use of *bottles/traps* to catch organisms and to refer to *choice of location and timing; placement of bottles/traps; use of Tullgren funnel, identifying and counting organisms and recording relevant data*. Two good responses were:

- In the habitat dig holes and place bottles covered with leaves to produce pitfall traps to trap Organism 5.
- Distribute the bottles in the entire area
- Collect the bottles after one day
- Count the number of the population

And

- Select and name a suitable habitat
- Dig holes at regular intervals and bury bottles leaving the mouths at the surface of the ground
- Lightly cover with grass and leave overnight
- Take bottles to the lab, observe the results by counting the organisms

- Tabulate observations

Part (c) (v) asked candidate to define the term ‘carnivore’ and give two adaptations a carnivore in the soil sample should have. This question was fairly well done, even though quite a few candidates held some misconceptions about carnivores. Some candidates believe that carnivores feed on herbivores only or that they are living things with backbones. With respect to the adaptations, most candidates were able to access one of the two available marks. Candidates were expected in their responses to refer to: *locomotory structures, fast movement; mouth parts for trapping, biting, piercing; cutting, developed sensory system for detecting prey*. Examples of good responses were:

Two adaptations are sharp teeth or stingers and poison or venom to stun and kill prey  
... mouth parts to trap and kill animals and should be able to move quickly or to be well camouflaged to catch them. Therefore, have a great number of legs or be colored to match the colour of the habitat.

### Misconceptions

- Quadrats or nets can be used to determine the population of organisms in a leaf litter.
- Carnivores eat ‘organisms’. They should note that the term ‘organism’ refers to both plants and animals.
- Carnivores are living things without backbones.
- All invertebrates are insects.
- Earthworms recycle soil nutrients.
- Recycling of nutrients only involved organisms which physically break down the material, for example, earthworms.

### Question 2

This question tested candidates’ knowledge of parts of the appendicular (joint) and axial (vertebrae) skeleton in humans. Candidate performance on this question was disappointingly weak although not entirely unexpected. The mean was five and the mode was three.

In Part (a), candidates were to label the parts identified by numbers on diagram of the mammalian joint illustrated in Figure 4 (Part (a) (i)) and state the function of two parts selected from the diagram (Part (a) (ii)). Part (a) (i) was very poorly done. Candidates were expected to label as follows: *1 – synovial membrane; 2 – synovial fluid; 3 – cartilage; 4 – bone*. Since these are commonly known parts of a joint, it is quite surprising that many candidates failed to provide accurate labels, and too often interchanged the names or incorrectly spelt the names. Performance on Part (a) (ii) was somewhat better in that many candidates were able to relate *the synovial fluid to lubrication of the joint to reduce friction* and *the bone with providing attachment for muscle, its role in movement, support or red blood cell production*.

Part (b) also proved challenging for a large number of candidates. They were required in Part (b) (i) to name a partially movable joint. Few candidates knew that the *wrist, ankle (gliding/sliding), atlas* and *axis (pivot)* are classed as partially movable. Part (b) (ii) was fairly well done since a fairly large number of candidates recognised the elbow as *a hinge joint which allows gross movement – flexing and extending the lower arm, over a wide area*. Many, however, were vague in referring to the *limited or restricted movement in the partially movable joint* in making the comparison between movement at the two types of joints which Part (b) (ii) of the question asked.

Part (c) required candidates to complete a diagram of a human forelimb to illustrate how antagonistic muscles are aligned. This part of the question was fairly well done in that while candidates knew that antagonistic muscles, in this case, the biceps and triceps are on opposite sides of the humerus, many had little knowledge of how they were attached to the radius/ulna.

In Part (d), candidates were asked to explain how in older persons the hip bone can lose its locomotory function. This part of the question was also fairly well done. Candidates were expected to include in their responses ideas such as: *the hip bone carries the weight of the torso; loss of bone mass/erosion of cartilage at joint possible; reduction of synovial fluid; increased friction at joint; physical damage to the hip bone through injury possible*. Thus, in general candidates recognised that locomotion could be impaired through a loss of effectiveness at the joint. A good response to this part of the question was:

Cartilage around the ball and socket joint may wear away causing frequent rubbing of bones. Older persons may lack calcium in their diet giving rise to brittle bones especially those of the hips. Both cause pain during walking or movement of the hip joint.

Some misspelt words included:

Cartilage – “cartalage”, “cartillage”

Synovial – “sinoval”, “cernovial”

Wrist – “rist”, “wrisk”

Misconception

- Cranium is a partially movable joint
- Hinge joints move in two planes, back and forth

Question 3

This question required knowledge of the process of meiosis and its implications, as well as the processes involved in genetic engineering. The question was reasonably well done given that the topic is among the more challenging aspects of the CSEC Biology syllabus. The mean was 4.5 out of 15 with a mode of three. Very well prepared candidates were able to attain marks across the full range available for the question.

Part (a) of the question dealt with aspects of meiosis based on the representation on a diagram showing chromosomes in a dividing cell that was labelled Figure 6. Candidates generally provided accurate labels of the chromatids and centromere respectively which were required in Part (a) (i) and were able to identify the process as meiosis which was asked in Part (a) (ii). While several candidates were able explain why the process was indeed meiosis required in Part (a) (iii), many more were

unable to articulate their reasoning. Candidates were expected to refer to: *pairs of homologous chromosomes separating; centromere intact; evidence of crossing over in homologues*. An excellent response was:

...pieces of chromosomes have been exchanged. This only occurs in meiosis. The chromosomes are being separated and are still composed of 2 chromatids joined at the centromere....

Part (a) (iv) asked candidates to indicate the number of chromosomes in the daughter cells produced in the cell division illustrated. A majority of candidates obtained the mark allocated to the question, but far too many ignored the stimulus material and gave the number of chromosome in a human gamete, which was not asked for. For Part (a) (v), candidates were to give two advantages of meiotic cell division. Candidates were expected to refer to concepts such as: *maintenance of the genetic number through successive generations; gametes different/offspring show variation; increase chances of survival as environmental conditions change*. A good response was:

It can produce genetically different offspring which may be of better quality. The organisms' offspring which are genetically different may be able to survive environmental conditions if they change drastically.

Part (b) of the question assessed candidate knowledge of genetic engineering and its implications. In Part (b) (i), candidates were to define the term 'genetic engineering'. Candidates for the most part did not draw on the significance of manipulating genes and that the process was done at the sub cellular level. They were expected to indicate that: *genetic engineering involved the transfer; human manipulation; across species; at the sub-cellular level; not limited to or by species*. A good definition was:

Genetic engineering is the insertion of genes into the DNA of one organism from another by humans.

In Part (b) (ii), candidates were to give an advantage of genetic engineering. This part of the question was well done. Candidates were expected to refer to: *faster change in trait; targeted traits involved; any trait can be manipulated/changed; any organism can be affected/changed*. In the following example this candidate illustrated how genetic engineering might be used to help find a cure for systemic, difficult-to-cure diseases:

Diseases such as cystic fibrosis may be cured by inserting new healthy genes in place of genes carrying the disease.

However, challenging for candidates was Part (b) (iii) in which they were to identify possible problems that could arise with genetically modified organisms. Candidates were expected to refer to the unknowns about modified traits and their impact on the environment: *the new trait may cause organism to impact the environment differently and negatively; change in role in food chain, web; ability/inability to switch genes on and off*.

Part (c) of the question asked candidates to explain why gene transfer between species is successful even though those species cannot normally interbreed. This part of the question was not well done by candidates. Candidates were expected to indicate that *in general, organisms similar at the genetic level; gene structure is the same in all living things; transfer of genes possible between vastly*

*different species; interbreeding is a complex of activities – involving many structures and processes, gametes different.* A response that gained full marks was:

This is possible because humans are controlling the gene transfer by inserting the genes directly into the DNA of an organism ... normally, species do not interbreed as they cannot easily fertilise eggs of another species

Misconceptions/misconstructions:

- Lack of understanding that genetic engineering occurs at the sub-cellular level
- Lack of understanding that genes of all living organisms have a universal structure

Question 4

This question assessed the depth of candidates' understanding of the energy flow in ecosystems and their ability to evaluate the principles and implications of biological control. Approximately half of the candidates obtained over half the available marks for this question. The performance was thus quite good. The mean was almost seven out of 15 and the mode was eight.

Part (a) (i) of the question dealt with energy flow to and within ecosystems. The concept of plants as producers for the system because of their unique light- absorbing and energy conversion characteristic was widely understood. A good response was:

They are the only organisms that can readily make use of the sun's energy. They use it to perform photosynthesis by which they make their food; herbivores eat these plants to gain energy and carnivores eat the herbivores and other carnivores for energy.

In Part (a) (ii), candidates were required to show how a plant or animal may belong to more than one food chain. While many candidates were able to draw reasonable diagrams with multiple food webs, they should note that normally labels, annotations and peripheral writings should be used to explain concepts and ideas presented in illustrations. In Part (a) (iii), candidates were required to explain why the number of organisms decreases at successive trophic levels. This part of the question was poorly done by several candidates, because they were unable to relate the decrease in number of organisms to energy loss to the environment. Further, simply stating that energy is lost is an inadequate response. Candidates were expected to include in their responses the ways in which energy decreases up the food chain, as it is used up by organisms for metabolic processes, through heat loss in physiological processes, for example, respiration, excretion or in egestion. The following are examples of good responses. The first is succinct and to the point, while the latter illustrates how a good explanation is developed:

The number of organisms decreases at successive trophic levels because as we go up trophic levels, the energy passed on becomes less and less. In fact 90% of the energy is used, lost by heat etcetera because of the low energy being passed on, the trophic levels can only support fewer organisms...

... because at each level the amount of energy decreases. Energy is highest at the first trophic level because the sun's energy is abundant and only plants can make use of it for food. As herbivores consume plants they use some of the energy and store the rest, but



to get enough energy one herbivore may eat a lot of plants, therefore the number of herbivores is less than the number of plants ...

Part (b) of the question assessed candidates' knowledge of biological control and its implications. This part of the question was quite well done by able candidates, but presented a challenge to less able ones. For example, those candidates who were unable to identify a relationship that is important in biological control, which was one of the requirements of Part (b) (i) of the question, found great difficulty in explaining how the relationship functions in biological control, which was the other requirement of this part of the question. Candidates were expected to identify a predator /prey relationship or parasite/host relationship in their responses. In Part (b) (ii), candidates were to suggest reasons for a preference of biological control over the use of pesticides. Candidate response varied from coherent, well articulated arguments to the citation of totally irrelevant reasons such as "global warming" and "eutrophication". Candidates were expected to refer to biological control as *not likely to pollute the environment, contaminate food and drinking water* and that *pesticides had the potential to harm organisms not targeted*. Many candidates made reference to the development of resistance to pesticides, which, while valid, was too often poorly explained. Or they used terms vaguely, for example, "environmentally friendly" with insufficient explanation. Good responses to Part (b) (ii) were:

Firstly the use of pesticides poses the risk of bio-accumulation. This happens as a result of the chemicals accumulating in the bodies of organisms as we go up trophic levels. It usually affects the organism at the last trophic level most.

... chemicals could begin to accumulate in the soil and plants, poisoning and killing other organisms that feed on them and those connected in food chains. Extreme cases could cause mass destruction or even species extinction. The water in the soil could get affected ... overuse of pesticide may also cause the pest to become resistant to it ...

#### Misconception:

- Candidates often misinterpreted the use of pesticides in biological control making incorrect inferences to crops and plants.
- Pests become "used" to pesticides by antibody production.
- Organisms develop "immunity" to pesticides.

#### Question 5

This question required knowledge of the structure and function of the respiratory system in humans, factors that affect respiratory surfaces and the negative impact of human activity (factory emissions, cigarette smoke) on the environment. Candidate performance on this question was also good with a mean of 6.5 out of 15 and a mode of four.

Part (a) of the question tested candidates' knowledge of the structure of the human lung and how it is adapted for oxygen absorption. In Part (a) (i), they were to explain with the aid of a diagram how air reaches the lungs and oxygen absorbed into the blood stream. While the majority of candidates were able to provide an adequate explanation, the accompanying diagrams were indeed poor. This reflects a lack of appropriate drawing skill and is consistent with poor illustrations in SBA books. More

attention must be paid to developing candidates' drawing skill. Candidates were expected to include in their responses reference to *air passing through the nasal passage, bronchi/bronchioles, lung/alveoli* and then to *the capillaries surrounding the alveoli; the functioning of the ribcage and diaphragm in inspiration; oxygen dissolving in the moisture of the alveoli lining and diffusion of oxygen into the capillaries*. Several candidates were confused about where oxygenation of the blood took place and how the oxygen in the alveoli actually got into the blood stream. Part (a) (ii) asked candidates to suggest why it is important for human blood to have a specialized cell for oxygen absorption. This part of the question was not very well done. They sometimes referred to "surface area to volume ratio" but were generally vague in their explanations. They also tended to focus on what were the specializations of the red blood cells rather than the reasons for the special characteristics. Candidates were expected to include in their responses ideas such as: *oxygen is required by all cells; blood is the only means of supplying oxygen to all cells; many more cells requiring oxygen than cells of respiratory (absorptive) surface; specialized cells adapted to take up large quantities of oxygen and give up same to the cells that require oxygen*.

Part (b) required candidates to suggest why comparing the effects of smoke emissions from factories on leaves with the effect of smoking cigarettes on human lungs is appropriate. This question was challenging for many candidates. While they recognised that the leaves and lungs were indeed respiratory surfaces they could not rationalise the comparison. Candidates were expected to refer to the following facts: *smoke contains tar/solid particles; particles block stomata/ clog alveoli; reduction of gaseous exchange surface area, reduction of availability of gases in both humans and plants*.

Part (c) asked candidates to explain why governments should consider it their responsibility to reduce smoking in public. This part of the question was well done with most candidates gaining the marks allotted. A good response was:

They (the government) should consider it their responsibility because smoking causes lung cancer, chronic bronchitis and other diseases. The number of persons with these diseases can be increased if the public is exposed to second-hand smoke and thus can cause a strain on the country's health services. Also, most smokers are young men and women and when they become sick there are fewer working people in the population to provide income for the country.

### Misconceptions

- No difference between the trachea and oesophagus.
- Oxygenation of blood took place in the heart.
- Carbon monoxide is interchangeable with carbon dioxide.
- How acid rain is formed.
- Low availability when carbon monoxide is present.

### Question 6

This question investigated candidates' knowledge of diseases and how the body is able to defend itself against diseases, antibiotics and implications of improper use as well as the impact of alcohol

abuse. Performance on this question was good with a mean of seven out of 15 and a mode of seven, giving a classically normal distribution curve. Candidates were able to access marks across the full range allotted to the question.

In Part (a) candidates were asked about the body's disease defence system and its effectiveness. In Part (a) (i), candidates were asked to explain how the body defends itself against disease. Candidates often did not provide a comprehensive enough account of the functioning of the immune system. Candidates were expected to include among other concepts: *clot formation; role of white blood cells, immune system response including production of antibodies, destruction and removal of antigens, memory cells and their role*. For Part (a) (ii), of the question candidates were required to identify diseases against which the body could not effectively defend itself. Most candidates were able to give at least one relevant disease which was often a viral disease such as HIV and AIDS. Too many candidates named obscure diseases when the obvious *hereditary*, for example, *sickle-cell anaemia, physiological*, for example, *diabetes or hypertension* and *viral diseases* were the expected responses. In Part (a) (iii), candidates were expected to indicate why it is difficult for the body to defend itself from one of the diseases identified in the previous section. Candidates were expected to indicate that these diseases were generally not caused by pathogens or antigens that *trigger the immune system* or that they *attacked and or destroyed the immune system itself or that the disease manifested at a sub cellular level that the immune system could not easily detect*. A good response from a candidate who indicated that the body has difficulty defending itself against a hereditary disease was:

It is difficult for the body to defend itself against hereditary diseases because these diseases are transferred in the genes of the parent to the offspring. They are not caused by pathogens and so cannot be acted upon by antibodies or phagocytes and must be treated differently for example, gene therapy

Part (b) asked candidates for two biological and two social implications of the improper use of antibiotics. This part of the question was not generally well done as candidates had to recognise that antibiotics are drugs that are used to *treat diseases caused by bacteria* and their actions are rather *specific to bacteria*. Thus, candidates were expected to refer to: *antibiotics used to treat bacterial diseases; development of resistance of bacteria to antibiotics when dosage not adhered to; increased chances of new strains of bacteria developing when antibiotics improperly used; lack of effectiveness of treatment*. With respect to the social implications of the improper use of antibiotics, candidates performed reasonably well and many alluded to the financial burden on the community/country. They were expected to include in their answers: *cost of health care/treatment of diseases; increased incidence of disease; susceptibility to epidemics; burden on families*. A good response to this part of the question with respect to biological and social implications of the improper use of antibiotics was as follows:

Two biological implications of the improper use of antibiotics are:

1. The bacteria will become resistant to antibiotics and will remain unharmed in the body.
2. The surviving bacteria will be stronger than its predecessor and will need an even stronger antibiotic prescription to be killed.

Two social implications of the improper use of antibiotics are:

1. The cost of extra doses of antibiotics and relevant research.

2. If the disease is communicable, the resistant strain of bacteria may infect other persons increasing cost for research and medication.

Part (c) of the question required candidates to offer an explanation for sometimes describing alcohol as an abused drug. This question was fairly well done by candidates. Many focused their responses on the effect on the nervous system including the feeling of euphoria and change of behaviour including addiction in those who consume excessive amounts. Candidates were indeed expected to develop their responses around the ideas of: *alcohol is a depressant of the nervous system; alters normal functioning of the body; addictive for some people/increase dependence; drinker becoming more sociable and self-confident/feeling of euphoria/less social responsibility; need to drink excessive amount to maintain euphoria; need to be treated as any other disease that must be controlled.*

### Misconceptions

- Antibiotics are used to treat any or every type of disease.
- Antibiotics can be used to treat viral disease.
- One can overdose on antibiotics in the same way one can overdose on alcohol or illegal drugs.

## **PAPER 03 – School-Based Assessment**

### **GENERAL COMMENTS**

Performance on the School-Based Assessment was reasonable. The syllabus coverage for centres was generally good and it was evident that there was some attempt to conduct practical activities for most skills. However, while the skill of Observation, Recording and Reporting (ORR) was generally well done, Analysis and Interpretation (AI) and Planning and Designing (PD) continue to present candidates with the most difficulty. It is recommended that more practical work, and work providing opportunity for developing these specific skills, form a greater part of the Biology course. In general, practical work should have an experimental approach that facilitates the development of critical experimental skills which is a major goal of the SBA. Efforts must also be made to include fieldwork for each batch of candidates.

A review of previous school reports will provide further suggestions for developing practical skills. Further suggestions are reiterated in this report and each teacher is alerted to the specific strengths and weaknesses displayed by their candidates in the Moderation Feedback Form sent to schools from CXC, after moderation. Teachers should also review the 2002 School's report to obtain an overview of the moderation processes and the expectations of the moderators.

While the quality of the books submitted from several centres was good, there are still some centres that submitted books without the requisite information. The CXC Biology syllabus provides guidelines for the preparation of practical books for submission. Some of the requirements include: a Table of Contents with aims of the practical activities, page numbers, dates, and a clear indication of the skills being assessed. In addition, the marks awarded for each practical activity must be placed

aside the practical and not listed at the front or back of the books. There must also be clear and specific indication of the activities that are used for the SBA.

The moderation exercise is too often hampered by poor mark schemes. These must be prepared and submitted with due care and attention. Mark schemes must be legible and preferably bound together instead of on loose sheets of paper. There must be a clear and direct relationship between the marks awarded to the appropriate activities in the practical books and to the marks on the tally sheets. It should also be noted that no more than two skills should be assessed in a practical activity.

The following is a list of criteria which teachers should follow in marking SBA activities.

- Marks should be awarded for each skill separately. It is noted that in some cases, marks were given for each skill, then tallied to give a composite score.
- Marks awarded to students' work should be a fair indication of its quality. Too many students received high marks for work that obviously fall short of the CXC standard. This was particularly noticeable for Planning and Designing, Analysis and Interpretation, and Drawing. When the CXC standard is not observed there is great disparity between the teacher's score and that of the moderator. This circumstance is usually **disadvantageous** to the students.
- Marks submitted on the moderation sheet should reflect the candidates' marks in each of the samples. Consistency of marking and submission of marks relate to the reliability of the process and thus acceptability of marks submitted.
- Teachers are once again reminded that body fluids such as saliva, blood and urine are not to be used for practical work. These can be sources of infection and may have serious legal implications should a student become infected while conducting practical work. Plant materials must be removed from books before they are submitted to CXC, since these are also potential agents of infection when moved from place to place.
- Fieldwork, both quantitative and qualitative aspects, is critical to the study of Biology and must be included in the SBA submissions

The moderation feedback form, which is sent to each centre, provides constructive and useful information relevant to the particular teacher(s). This form offers specific recommendations and is intended to assist teachers in the planning, conducting and assessing practical work – in the laboratory and field. Improvement of students' practical skills will have a direct influence on candidate overall performance in the Biology examination, since certain questions, notably Question 1 on Paper 02, are based on knowledge and application of these practical skills.

## **SPECIFIC COMMENTS ON THE ASSESSMENT OF SKILLS**

### **Observation, Recording, Reporting (ORR)**

These skills appear to have been mastered at most centres. For most of the work observed, the method was clearly described with logical sequence of activities. The tables and graphs were clear and provided adequate details which allowed for clear description and discussion of the experiment. It

was also observed that except for a few centres, the past tense was correctly used in the presentation of the report on the practical activity.

The importance of fieldwork is reiterated here. At some centres, little or none is being done. Many centres that attempted fieldwork frequently neglected quantitative or qualitative investigations. Both aspects of fieldwork are expected. Investigations need not be elaborate but students should be given the opportunity to explore the environment and make observations about the relationships among living organisms and their environment.

### **Drawing (Dr)**

The number of drawings included in candidates' practical books, as well as the quality of the drawings, continue to be of concern to the Biology Examining team. At too many centres poor drawings were awarded high marks. Drawings are not expected to be works of art, but they should demonstrate an adherence to the guidelines for accuracy, clarity, labeling and magnification. Students have to be given several opportunities to develop drawing skills. The larger the number of drawings students have to produce, the more opportunity they have to practise, and develop the skill. It is also emphasized that drawings must be practised from actual specimens and not from textbooks. This comment has been stressed in several school reports.

Teachers must ensure that their students draw samples of **flowers, fruits, storage organs and bones**. Additional examples may be included in practical books. However, **microscope drawings should not be used for SBA**. It is very useful for students to see and attempt to record what they do see under the microscope but at this level these drawings should not be used for SBA. Similarly, dissections may help students to understand structures such as the digestive system but they are too complex to be drawn accurately at this level. These difficult drawings do not provide a fair test of ability at this level.

### **Analysis and Interpretation (AI)**

This skill continues to present problems for the majority of candidates. The processes involved in demonstrating this skill are reiterated here.

Discussions are expected to provide some background information or the general principles on which an investigation is based. Results should then be explained. When a control is used it provides a point of comparison for the experimental set up in which a particular variable has been omitted. This comparison should be included in the discussion as it is the key to drawing the conclusion. Conclusions should relate directly to the aim of the investigation. Students should also be reminded to discuss at least one limitation of the investigation. It is important for them to recognise that the conditions present in a school laboratory are rarely ideal.

Many teachers continue to use questions to stimulate discussion. This device is good for helping students to develop their AI skills. However, they should not be used excessively, nor should they be the only means of assessment. These questions must guide students to provide the required background information, give explanations for the results, draw conclusions and show an awareness of possible limitations. The information provided in this way should then be written up as a paragraph of continuous prose as is normally done for the discussion/ conclusion. In many cases, candidates seem to have learnt a formula for writing up the discussion but showed no real understanding of how to interpret their own results. As a learning strategy teachers may ask their students to orally explain

the results to obtain a clearer view of their understanding and to help them develop their analytical skills.

It should be noted that food tests on their own are not appropriate for assessing AI. Simple investigations can be designed in which food tests are used. For example, students can be given unknown mixtures and asked to find out which food would be most suitable for an infant. Food tests can be used also to determine the presence of a particular food before and after digestion by an enzyme. These types of exercises will allow students to develop the necessary skills. Knowledge of the food tests and the nutritional requirements can then provide the background information on which they will base their conclusions.

Moderators were also concerned about the narrow range of investigations assessed for AI. With the exception of patterns of growth in seedlings, very few candidates seemed to have been exposed to investigations other than experiments. Investigations that require collecting observations over a period of time are ideal for discussing limitations as they lack controls and so many variables may change. These limitations can then be used as the basis for planning and design exercises. For example, students can be asked to find out which of the flowers in a garden butterflies prefer or what types of moths a house lizard eats by completing a table of observations over a period of days or weeks. They can then use the observations to develop a hypothesis and design an investigation that would test it.

### **Manipulation and Measurement (MM)**

As in previous years, the marks for this skill were good. However, as was stated in previous reports, in many cases there was reason to believe that these marks were not the result of rigorous marking. If virtually all students in a class gain full marks on an activity, perhaps the task is not demanding enough or the criteria not detailed enough to allow the necessary discrimination between different levels of performance. It is important that students be exposed to a wide range of apparatus and their use in collecting data. This would help to ensure the development of the skill and give a fairer assessment of student competence in MM. Teachers are reminded that marks for MM must be written down in the laboratory books next to the laboratory practical for which they were awarded and mark schemes and detailed criteria submitted as done for all other skills.

### **Planning and Designing (PD)**

Performance on this skill was fair. Most experiments designed by the students indicated that there was some understanding of the procedures involved in planning and conducting an experiment. There are still a few areas of difficulty where candidates were unable to state their hypotheses clearly and relate the aim to the hypothesis. In some instances, there were no replicates in the investigations.

There is room for more creative experiments. Teachers should take examples from their environment that would challenge the ability of their students. It is also important that development of the skill start with the commencement of the teaching of the syllabus. In many cases it was obvious that practical activities targeting the development of the Planning and Designing skill was among the last set of activities in which the candidates engaged prior to the examinations. Figure 1 is a noteworthy submission from 2005 SBA which clearly illustrates how a planning and designing activity might be effectively developed.

**Example:**

This Planning and Designing activity submitted by a centre was based on the observation that “*A boy notices that all the trees around his yard except the grapefruit tree were infested with ‘duck’ ants*”. The students were required to plan and design an experiment to determine what was responsible for the difference in infestation. An example of an appropriate hypothesis and a relevant aim for investigating the hypothesis was:

***Hypothesis:** ‘Duck’ ants will appear on some trees but will not be present on grapefruit trees because the leaves contain a chemical that repels the ants*

***Aim:** To investigate whether ‘duck’ ants are repelled by a chemical from the leaves of the grapefruit tree.*

There was a clear description of the materials and method. Students planned to extract the substance from the leaves of the grapefruit tree, which may be responsible for the repellent effect, along with extracts from the leaves of other trees as an appropriate control. The ‘duck’ ants would then be placed near drops of each of the extracts in petri dishes. The measurable variable would be the number of ‘duck’ ants that leave or remain in each dish. Results would then be tabulated and subsequently discussed.

As stated by the candidates, one limitation may be that ‘the chemical in the leaves that cause the effect on the ‘duck’ ants may be affected by the extraction’. Appropriate marks were awarded for the various aspects of the experiment.

**Figure 1.** Example of a good Planning and Designing activity



**CARIBBEAN EXAMINATIONS COUNCIL**

**REPORT ON CANDIDATES' WORK IN THE  
CARIBBEAN SECONDARY EDUCATION CERTIFICATE  
JANUARY 2009**

**BIOLOGY**

**BIOLOGY**  
**GENERAL PROFICIENCY EXAMINATIONS**

**JANUARY 2009**

**INTRODUCTION**

The January 2009 sitting of the CSEC examination in Biology differed from previous January offerings in that the examination consisted of three papers on which all questions were compulsory. The papers were as follows:

- Paper 01 – Multiple Choice
- Paper 02 – Structured /Essay Questions
- Paper 03/2 – Alternative to the School-Based Assessment

Performance of candidates in this examination was as anticipated, particularly performance on Paper 02. Performance on Paper 03/2 – the Alternative to SBA was somewhat disappointing and highlighted the lack of practical experience and the moderate development of required biological skills and practice. Also contributing to weak candidate performance was the lack of attention to test-taking techniques and the disregard for suggestions made by the Examining Committee, which have been made repeatedly and which have been embellished and are reiterated hereunder because of their critical importance to future candidates of the Biology examination:

- Candidates must improve their test-taking skills. This includes practice in reading questions carefully and planning responses so that answers are organized in a logical and coherent manner.
- Candidates continue to waste a lot of valuable time providing irrelevant information in the essays, even though guidance has been provided in the spaces allotted to the expected responses. Candidates should focus on key words such as ‘describe’ and ‘explain’ when reading the questions and be guided by the mark allocation and quantitative descriptors within the text of the question as far as possible.
- There was also the question of choice of terminology and descriptions provided. Familiarity with biological jargon allows candidates the opportunity to express themselves more accurately and reduces errors caused by oversimplification.
- Candidates should pay more attention to the stimulus material provided in the questions, especially in the first three questions. Candidates often digress from the point or, as happened in this particular paper, refer to experimental activities outside of what is requested. The stimulus material is meant to guide the candidate to the expected responses. Too often candidates respond by providing obscure information in their responses that do not relate to the scenario presented, or they ignore the obvious in favour of little-known phenomena.
- More emphasis should be placed on practical skills and the candidates’ ability to demonstrate these skills in responding to questions on Paper 03/2. Too many candidates seemed unfamiliar with basic laboratory equipment and material and even the simplest of biological/scientific methods. Candidates demonstrated particular weakness in stating hypotheses and aims and in describing methods of common experimental activities, like food tests.

- The spelling of common biological terms is generally so poor that candidates cannot be rewarded with marks. It is also difficult to explain why candidates would incorrectly spell biological terms used in the question.

### **Paper 01 - Multiple Choice**

Paper 01, consisted of 60 multiple-choice items. Performance on this paper was similar to that of 2008. Some of the topics that *continued to be* problematic for candidates were:

- Aspects of ecology including feeding relationships and food chains
- Cell structure and function
- Specifics of photosynthesis
- Specifics of respiration
- Cell specialisation
- Morphology of root, stem and leaf
- Phloem structure
- Reflex arc
- Aspects of nutrition, for example, role of different vitamins
- Aspects of respiration and excretion
- Joints
- The functioning of sense organs
- Metabolic rate and effect on body temperature

### **Paper 02 - Structured/Essay Questions**

Paper 02 consisted of six essay questions, three of which followed the short-answer format and three that were more extended in structure. The first question which carried the heaviest weighting, 25 marks, was the data analysis question, which assessed candidates across all profiles. Thus, this paper tested all profile skill areas identified in the Biology syllabus. Candidate performance on this paper was not as good as anticipated, with several questions showing very low modes of 0, 1 or 2. This is below the expected performance standard and speaks to both inadequate preparation of the candidates writing this examination and their weak test-taking skills.

Candidates were able to attain marks across the allotted range for only two of the six questions. For more candidates to give their best performance, attention must be paid to observations and suggestions the Biology examiners have repeatedly made. In particular, candidates' attention is drawn to the use of the stimulus material in responding to the questions and the guidance provided by the spaces allotted to each question – answers should relate to the stimulus material and should be kept within the allotted spaces. In addition, in preparing for the examination all topics on the Biology syllabus must be studied and adequately prepared. It was quite obvious that inadequate attention was paid by this candidate population to segments of the Biology syllabus, including genetics and variation, and experimental activities, such as, the methods for various food tests.

***Candidates must note that they are not required to repeat the questions to begin their responses for the first three questions of the paper. This is a waste of time and of the space allocated for their response to the question.***

Candidates sometimes missed key words in the questions and provided answers which were off the point. It is thus suggested that candidates should be advised to read through each question *carefully*, *highlighting key words on which the questions hinge*, so that they would be less likely to misread and misinterpret questions.

Candidates continue to misspell common biological terms, for example, *epidermis* and *dermis*, and run the risk of losing marks unnecessarily.

### Question 1

This question dealt with some practical aspects of Biology including data representation from an investigation on enzyme action, methods of obtaining data from an enzyme investigation and knowledge of the location of enzyme activity in the human digestive tract. Candidates' performance on this question was reasonable. Marks were distributed across the full range and showed a relatively normal distribution. The mean mark was **11** with very close modes of **10** and **12**.

Part (a) of the question examined candidates' knowledge of data representation techniques and their ability to read and interpret data presented in graphical format.

In Part (a) (i), candidates were required to use data on the rate of reaction of two enzymes at different pH levels, presented in a table, to complete a graph to represent the information. Most candidates were able to obtain at least half the marks assigned to this part of the question. However, several candidates lost marks because they failed to state a title, in spite of the prompt on the paper, or they failed to plot all the points correctly.

In Part (a) (ii), candidates were to explain why the rate of reaction for the enzymes was sometimes zero. Most candidates recognised that no reaction occurs outside of the range of function of the enzymes due to the enzymes being inactivated or denatured. Weak candidates made reference to temperature levels affecting the enzymes.

Part (a) (iii) required candidates to read information from the graph and interpret the data. Most candidates performed creditably in determining the optimum pH for each enzyme and in deciding which enzyme functioned at the lower pH and which produced more products. However, many candidates had some difficulty in providing a reason for determining whether or not Enzyme X and Enzyme Y were similar. The majority suggested that the enzymes were similar because they operated in ranges that were similar or that they operated at optimum levels that were close. However a good response would have included that the ranges actually *overlapped*.

Part (b) of the question was especially challenging for candidates who had little or no practical experience with food tests. They were required to describe the apparatus, including materials, method and expected results, to confirm the presence of a reducing sugar among the product of reactions catalysed by enzymes X and Y. In naming the apparatus (and materials), the substance to be tested was often not related to the question and several, perhaps weaker, candidates often named materials they may have tested in the past for reducing sugar, such as, glucose solution and chives. A frequent omission from the candidates' responses was the reagent to be used, preferably Benedict's (or Fehling's) solution to conduct the test. Candidates familiar with the test procedure included the use of a *water bath* and *test tubes*. The description of the method was generally not well done. Several candidates stated that they would add Benedict's solution to the enzyme suggesting that they did not recognise that they were to test the *products* of an enzyme-catalysed reaction. They generally also failed to indicate that Benedict's solution must be heated to observe the colour change. The quantity of test substance and reagent was rarely mentioned. Generally, candidates were able to correctly indicate the brick-red/orange precipitate as the expected result and obtain the mark allotted to that part of the question.

Part (c) of this question examined candidates' ability to relate the information on enzyme reactions gleaned in the earlier parts of the question to their knowledge of the behaviour of digestive enzymes in the human alimentary canal. Candidates were told that Enzyme X and Enzyme Y broke down the same nutrient in digestion but were produced by different organs of the human digestive system, and were asked in Part (c) (i) to identify the enzymes. This was very poorly done by the candidates. Very

few candidates recognised the digestive enzymes were *amylase – salivary amylase* found in the mouth and *amylase found in pancreatic juice* in the duodenum.

In Part (c) (ii), they were to indicate the location of the enzymes on a diagram of the alimentary tract and associated organs. Candidates who got Part (c) (i) correct were generally able to correctly indicate the *mouth* and the *pancreas* or *duodenum* respectively.

Part (c) (iii) asked candidates to suggest advantages to humans of having two forms of the same enzyme. Candidates performed creditably on this part of the question. Their responses include reasons such as: *making digestion of food more efficient/ faster/more opportunity for digestion to be completed if an enzyme in one section fails to function*. A good response was:

... the food is able to be completely broken down and the different forms of the enzyme can function in different environments, that is pH ...

Part (d) of the question explored candidates' knowledge of digestion (breakdown) of stored food in plants and of substances used in making plant food.

Part (d) (i) asked candidates to suggest one condition or circumstance when digestion occurs in a plant. This part of the question was fairly well done. Candidates included in their responses such ideas as: *germination, growth and translocation of nutrients stored in leaves/storage organs*. Some candidates incorrectly stated 'respiration'.

Part (d) (ii) asked candidates to name two inorganic substances (mineral elements) required by plants to make their food. Far too many candidates seemed unfamiliar with what mineral elements are. These candidates named water, carbon dioxide and sunlight. The expected responses were *nitrogen, phosphorous* and *magnesium*.

## Question 2

This question tested candidates' knowledge of the anatomy of human skin and how the skin controls body temperature and other functions, as well as their ability to apply their knowledge of the healing process in the skin after injury. The question also examined candidates' knowledge of the need for temperature regulation in plants. Candidates performed reasonably well on this question. Candidates scored across the entire range from **0** to **15** marks. The mean mark for this question was **6** and the modal mark was **7**.

Part (a) of the question examined candidates' knowledge of the anatomy of the skin.

In Part (a) (i), candidates were asked to identify the three layers labelled in a diagram of a longitudinal section through the human skin. This part of the question was not very well done. Many candidates seemed unfamiliar with the gross anatomy of the skin. Several candidates gave names more appropriately associated with the layers of the dicotyledonous leaf, such as, 'upper epidermis', or simply described them as 'outer', 'inner' and 'middle' layers. Better performing candidates correctly identified the layers as *1 – epidermis, 2 – dermis, and 3 – fat*.

In Part (a) (ii), candidates were required to identify two structures on the diagram that aid in temperature regulation in humans. This question was well done by most candidates. However, a frequent error by candidates was the inclusion of the 'hair'/'follicle' or 'sweat pores' as part of their response. The expected response was *capillaries* and *sweat glands*.

Part (b) of the question addressed aspects of injury and healing of the skin.

In Part (b) (i), candidates were asked to suggest how the functions of the skin would be affected if the skin lost its epidermis after being burnt. This part of the question was fairly well done. A good candidate response was:

The skin will lose the ability to feel due to damaged nerve endings; the lower layers could be easily damaged and infected due to exposure to bacteria.

Part (b) (ii) asked candidates to give one advantage of grafting onto a burnt area, skin taken from another part of an individual's own body. This part of the question was not well done. Candidates generally failed to recognise that grafting with skin from the same individual reduces the risk of rejection or the production of antibodies that are likely to

- *reduce the rate of the healing process;*
- *require/force the taking of drugs to reduce rejection of the graft or*
- *bring about dependence on finding the right donor.*

A good candidate response was:

The skin is allowed to grow back and is not rejected by the body, the replaced skin can function more normally faster and it is also an advantage in the cosmetic sense.

Part (c) asked candidates to suggest a reason why a plant also needs to regulate its temperature. This part of the question was not at all well done. In many cases candidates provided explanations that were inaccurate/failed to consider the rate of plant metabolism. Candidates could have mentioned effect on physical processes, as well as chemical reactions particularly those driven by enzymes. Candidates were expected to include in their responses: *effect on plant metabolism, for example, the rate of photosynthesis/ respiration; effect on enzyme reactions in metabolic processes/ effect on some physical processes, for example, transpiration.*

### Question 3

This question tested candidates' knowledge of monohybrid inheritance and variation. Performance on this question was weak. Many candidates seemed unfamiliar with these biological concepts and several provided no response to the entire question or parts of it. While candidates scored across most of the range for the question, from 0 to 14 out of 15 marks, the mode was 0 and the mean was 4 marks.

Part (a) of the question tested candidates' knowledge of colour inheritance in the flower of a familiar plant.

In Part (a) (i), candidates were required to complete a table to show the genotype of gametes of pure-breeding flowers and the F<sub>1</sub> genotype after breeding. Candidates were also required to provide the phenotype of the F<sub>1</sub> generation. This part of the question was fairly well done, although many candidates could not distinguish between genotype and phenotype.

In Part (a) (ii), candidates were to predict the phenotypic ratio if the F<sub>1</sub> plants were crossed. Sometimes candidates gave the ratio without stating the respective colours and vice versa which lost them one mark. However, this part of the question was fairly well done.

Part (a) (iii) was very poorly done. Candidates were asked to identify the type of variation that was shown by the flower colour. Candidates were expected to distinguish between variation in which clear differences are observed or in which there are distinct categories and identify *discontinuous variation*. An example of a good candidate response was:

The type of genetic variation shown is discontinuous. The differences are separate and clear cut. The white and red flowers produce pink flowers. The differences are clearly seen and do not merge into each other.

Part (b) investigated candidates' knowledge of the concepts of co-dominance and incomplete dominance in inheritance.

In Part (b) (i), candidates were asked to distinguish between co-dominance as observed in blood groups, as opposed to incomplete dominance shown by the *Impatiens* flower referred to in Part (a) of the question. Candidates who had done this part of the syllabus performed creditably. Those who were unfamiliar with the topics generally omitted this part of the question. Candidates were expected to include in their responses: *co-dominant indicates equally dominant, thus phenotypes of both parents are evident in offspring; for incomplete dominance blending of phenotypes occurs, thus the phenotype differs from parents.* A good response was:

Co-dominance is when there is an expression of both alleles, whereas incomplete dominance is when there is a blending or combination in the expression of the alleles.

In Part (b) (ii), candidates were to predict the phenotype of the *Impatiens* flower if flower colour showed co-dominance instead of incomplete dominance. Very few candidates were able to provide a convincing answer. They may have indicated the presence of the two colours but they did not indicate how the colours were distributed – *in patches of red and white on the flower*, which was the expected response.

Part (b) (iii) examined candidates' knowledge of inheritance of blood type. This part of the question was fairly well done. Candidates were generally able to complete the diagram, but had some difficulty in illustrating the phenotype. They often expressed the phenotype by repeating the genotype. The expected response was:

Parental Genotype:	AO	x	BO	
Gametes:	A	O	B	O
F <sub>1</sub> genotype:	AB	AO	BO	OO
				OO = Blood group O

#### Question 4

This question examined candidates' knowledge of the process of photosynthesis and some conditions that may reduce photosynthetic efficiency, as well as their knowledge of the use and effects of artificial and natural fertilisers. Candidate performance on this question was fairly good. There was general familiarity with the topics and candidates were able to gain marks across the spectrum from **1** to **15** marks. A few candidates, however, were unable to gain any marks at all. The mode was **5** and the mean **7**.

In Part (a), candidates were to describe with the aid of a balanced equation the process of photosynthesis. Many candidates were able to correctly provide a summary chemical or word equation for photosynthesis. Fewer candidates were able to provide an adequate description of the process. Some were unable to clearly define the roles of light and chlorophyll or ignored these factors completely. Others did not identify the reactants clearly, the source of reactants, carbon dioxide and hydrogen and the fate of the products, oxygen and glucose, were not adequately identified or described.

A good response was:

Sunlight is trapped in chlorophyll in the leaves. This energy is used to split water into hydrogen ions and oxygen gas. The hydrogen is then combined with carbon dioxide to form glucose. The reaction below shows this:

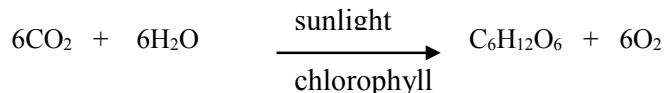

Part (b) of the question examined candidates' understanding of the impact of certain conditions on the process of photosynthesis in growing plants. This part of the question was fairly well done. Most candidates were able to relate conditions given in the examples to ways in which the photosynthetic process might be affected. Candidates were generally aware that the infestation of caterpillars cited in the first example would reduce the photosynthetic area and thus the capacity of the plant to produce the required quantity of food. Candidates did not perform quite as well on the second example, as many of them failed to recognise that the proliferation of algae will block light from reaching the water plants, thus reducing their ability to photosynthesise efficiently.

Good responses to Parts (b) (i) and (ii) were:

- (i) Caterpillars eat the leaves of plants. The leaves of plants contain the green pigment chlorophyll. This chlorophyll is what traps sunlight, the source of energy for photosynthesis to occur. Therefore, if the caterpillars eat the leaves of the tomato plant, the plant will not be able to trap sufficient sunlight and thus not make enough food.
- (ii) ... algae would coat the surface of the pond and prevent as much sunlight from entering. Therefore, the plant at the bottom of the pond would not be able to get enough light energy to make enough food ...

Part (c) dealt with candidates' knowledge of natural and artificial (chemical) fertilisers and the impact and effectiveness of their use. This part of the question was fairly well done as most candidates seemed familiar with the use of fertilisers in agriculture.

In Part (c) (i), candidates were required to suggest how the use of fertiliser increases crop yield.

In Part (c) (ii) and (iii) respectively, they were required to indicate two advantages of using chemical fertilisers and a benefit of using organic fertilisers.

Part (c) (iii) seemed the most challenging for candidates, as several failed to recognise that natural fertilisers *improve the crumb structure of the soil, improve its water-holding capacity and make minerals available to the plants on a slow and more continuous basis.*

A good response was:

- (i) Fertilisers increase crop yield by replacing and adding nutrients to the soil to enhance the growth of the crop and improve the quality. They ensure that the nutrients are readily available and the plant is well-nourished and so flourishes rapidly.
- (ii) Two disadvantages of chemical fertilisers is that they can kill helpful insects to the plants, for example, lady bird beetles which eat harmful insects... Secondly, when it rains, chemical fertilisers wash into drains and water courses, which eventually end up in the sea. These chemical fertilisers encourage the growth of organisms like algae and algal bloom (eutrophication) that use up dissolved oxygen and this is fatal to marine life.



- (iii) One beneficial effect of organic fertilisers ... is that it provides ample nutrient needs without becoming toxic or harmful.

### Question 5

This question tested candidates' knowledge of the process of respiration and means of obtaining the raw materials for the reaction, as well as their knowledge of types of anaemia and their various causes and effects on the functioning of the body. Candidates were able to gain marks across the entire spectrum of available marks from **1** to **15**, even though several candidates did not score at all. Performance on this question was reasonable. Candidates seemed to most easily access the marks in the parts of the question that dealt with anaemia and iron deficiency generally. The mean for this question was **7** and the mode was **7** marks.

Part (a) (i) of the question asked for a description of respiration in living cells. Candidates performed very poorly on this part of the question. Most candidates seemed to equate *respiration* with *breathing*. It must be clear that respiration refers to the chemical process by which cells obtain energy to do work. In responding to this question candidates were expected to refer to: the chemical process that takes place in the mitochondrion, *combination of food in the form of glucose with oxygen, glucose is obtained from digested carbohydrates, stored energy in glucose released and temporarily stored in ATP, ATP available as the cell needs, waste products carbon dioxide and water are given off*. A good response that earned full marks was:

Respiration is the process in which energy in food is made available to cells to do work necessary to keep them alive. Aerobic respiration is the oxidation of glucose, which means that the glucose and oxygen are the raw materials of respiration. The oxidation of glucose releases a significant amount of energy which is stored in little packets called ATP. This energy can be used when needed by the body. Respiration occurs in the mitochondrion of the cell.



Part (a) (ii), which asked how cells obtained raw materials for respiration, seemed well known by candidates. However, many candidates lost marks carelessly because they often only referred to one of the raw materials or while naming the raw materials they did not indicate that the glucose and oxygen were transported by the blood to the cells where the respiratory process occurs.

Part (b) investigated candidates' knowledge of types of anaemia.

In Part (b) (i), candidates were to identify likely symptoms of persons suffering from anaemia. This part was very well done. Candidates were generally able to provide two symptoms from: *weakness, fatigue, shortness of breath, increased heart rate or pale appearance*.

In Part (b) (ii), candidates were to explain how the oxygen-carrying capacity of the blood was reduced by sickle-cell anemia and iron-deficiency anaemia respectively. This question was fairly well done. Many candidates indicated in the first instance that the *sickle-shaped cells contained less haemoglobin and were less efficient carriers of oxygen, thus a smaller amount of oxygen was carried to the cells*. They were also able to state that *since iron is a part of the structure of haemoglobin, then fewer red blood cells will be produced if iron is in short supply and less oxygen will be transported*.

A good answer to this part of the question was:

- (a) The oxygen-carrying capacity of the blood is reduced by sickle-cell anaemia because of the shape of the cell .... The sickle shape of the cell results in less haemoglobin per cell and inhibits adequate amounts of oxygen from being picked up and carried throughout the body.

- (b) The oxygen-carrying capacity of the blood is reduced by iron-deficiency anaemia because there is a lack of iron to make haemoglobin which is used for transport of oxygen. Less haemoglobin means fewer blood cells will be produced, thus reducing the amount of oxygen transported.

Part (b) (iii) was very well done. Most candidates were able to suggest two ways of treating persons suffering from iron-deficiency anaemia which the question asked. Candidates identified the *use of foods rich in iron* and gave examples, and the *use of medication*, such as, iron tablets.

In Part (c), candidates were to suggest a reason why persons with diseases have a higher than normal number of white blood cells. This part of the question was fairly well done. Most candidates recognised that the increase in the number of white blood cells related to the role of white blood cells in protecting the body from invasion of disease-causing organisms. Some further explained the role of phagocytes in engulfing pathogens and of lymphocytes in producing antibodies. This was consistent with expected responses in which they were to indicate that the numbers of white blood cells would increase for reasons such as: *white blood cells are responsible for protecting the body from disease; in response to invasion by pathogens; in preparation for fighting the disease; in antibody production on invasion by pathogens.*

### Question 6

This question tested candidates' knowledge of aspects of pollination and asexual reproduction in plants as well as their ability to apply knowledge of relationships among living organisms to specific situations. Candidates' performance on this question was poor with a mean of approximately 4 marks and a mode of 2 marks, although candidates were able to score across the entire range of marks from 0 to 15.

Part (a) of the question required candidates to compare the structures of a wind-pollinated and an insect-pollinated flower. Candidate performance on this part of the question was weak. Many candidates were unable to draw an adequate representation of the two types of flowers, even though they were able to state some of the differences. In addition, several candidates did not make a comparison – sometimes stating the distinctive feature of one type of flower but not indicating the corresponding description on the other flower. Candidates were expected to make reasonably accurate representations of the two types of flowers which have highly distinctive features. They were expected to include the following ideas in their responses: *reduced non-essential parts/absence of petals/nectarines as opposed to colourful well-developed corolla/specially shaped corolla; feathery stigma vs. sticky stigma; elongated dangling stamens vs. fixed anthers; production of copious pollen in large versatile anthers vs. regular/normal amounts of pollen production.*

Part (b) examined candidates' knowledge of aspects of asexual reproduction in plants.

In Part (b) (i), candidates were required to explain two ways in which humans make use of the plants' ability to reproduce asexually. Performance on this part of the question was weak. Few candidates were able to identify the variety of ways in which asexual reproduction in plants was used. Candidates were expected to frame their responses using ideas like: *cuttings, tissue culture, storage organs, plantlets from leaves and so on.*

In Part (b) (ii), candidates were asked to give two advantages to humans of using asexual reproduction in plants. This part of the question was fairly well done. Candidates primarily considered advantages of *high yields in a relatively short time; cost effectiveness* and in *preserving valuable characteristics.* They were also expected to include other ideas such as: *maintaining yield levels in the crops* and *shorter time to maturity.*

Part (c) (i) required candidates to suggest likely risks involved in transporting living plant material from one territory to another. This part of the question was fairly well done. Candidates generally recognised that risks included the *transport of organisms and pests*, which might prove difficult to control in the new territory. However, they often failed to mention the *absence of predators* that can keep the new populations of pests in check or the *favourable conditions in the new territory can cause too rapid growth* and place the environment under stress.

Part (c) (ii) required candidates to suggest one way in which the likely risks may be reduced. This part of the question was well done. Candidates included in their responses several anticipated ideas: *inspection, certification, quarantine, processing* and original ideas for example, *education*.

### Paper 03/2 - Alternative To The SBA

This paper assessed all the practical skills required of biology students. Candidates continue to display weak practical skills, especially in aspects of planning and designing, including manipulating apparatus, describing methods of experiments and in drawing conclusions from data. These observations indicate that teaching for developing practical skills must include actual experimenting and investigating scientific phenomena, discussions, explanations and rationalizing of procedures and outcomes so that students become capable of developing and manipulating experiments and experimental data on their own.

#### Question 1

This question tested a range of candidates' experimental skills as would be required in conducting investigations of growth and development of bean seedlings. Candidate performance was reasonable, although there were no candidates gaining marks at the top of the range (24 to 25), no candidate obtained scores at the bottom of the range (0 to 2). Candidates displayed weak skills in describing methods for food tests and were not able to predict the changes taking place within a seed during germination. The mean for this question was approximately **13** out of **27** marks available, while the mode was **14** marks.

Given a series of illustrations (on graph paper) of seedlings at three stages of germination – 24, 48 and 96 hours respectively, candidates were required in Part (a) to make observations of the representations. They were asked to identify three plant features that had developed by 96 hours. Most candidates correctly identified the *root/radicle, plumule/leaves, and hypocotyl*. Several candidates incorrectly identified plant parts, such as, 'sepals', 'petals' and 'cotyledons'.

In Part (b), candidates were to measure the length of the epicotyl, which was labelled X on the illustration at 96 hours. Several candidates were familiar with the technique of using the grid to quickly arrive at the measurement of X. However, several candidates seemed unfamiliar with this technique, nor were they aware that X did not extend beyond the node of the first leaves of the seedling at one end and the cotyledons at the other end.

Part (c) of the question, which required candidates to describe a test to show whether the seed stored protein for germination, was fairly well done. Most candidates seemed to know that the reagents, *potassium/sodium hydroxide* and *copper sulphate* were to be used and a *purple colour* change was the expected result. Candidates who were unfamiliar with the test for proteins usually included a water bath in the apparatus and heat treatment in the method.

Part (d) investigated candidates' knowledge of the changes that took place within a seed during germination. Part (d) (i) and (d) (ii) respectively asked candidates to describe two changes that take place within the seed between 24 and 96 hours and the importance of these changes. This part of the question was not well done. Most candidates seemed to ignore the fact that the changes asked about

in the question were **within** the seed. Candidates were expected to include in their responses: *the breaking down of food stores/cotyledons by enzymes and translocation of digested foods to the embryo*.

For Part (d) (ii), candidates were expected to explain that the products/nutrients would be used as building blocks for new tissues and the provision of energy for growth activities.

Performance on Part (d) (iii) was quite good, as candidates were generally able to identify two environmental conditions important to the seedling at 96 hours. Popular responses were: *light, water, oxygen* and *carbon dioxide*.

Part (e) investigated candidates' knowledge of Planning and Designing techniques. Candidates were given a description of the method of an investigation of light on potted plants.

In Part (e) (i), candidates were required to provide a hypothesis for the investigation. This part of the question was not well done. Candidates were generally unable to state a good hypothesis. They often expressed the hypothesis as an aim or question. Candidates were expected to include in their responses suggestions about the role of light in growth of seedlings, for example: *bending of the shoot occurs because light affects auxin production*.

In Part (e) (ii), candidates were to suggest one way in which the method could be improved. This part of the question was also poorly done. Candidates were expected to refer to a control and include in their responses an idea such as: *seedlings exposed to full light*.

Part (f) investigated candidates' ability to manipulate and represent data. Candidates were given a table showing the growth of seedlings over a specified time period. Candidates were to complete a table of the average growth over the period by calculating the average stem length from data provided. They were then to construct a graph of average stem length over the period from the data obtained. Candidate performance was average.

## Question 2

This question tested the candidates' ability to make observations and appropriate biological drawings. Candidate performance on this question was relatively poor. Candidates continue to perform poorly on questions that involve the human skeleton and they continue to produce poor biological drawings and representations of biological phenomena. The mean score was approximately **5** marks out of a total of **17** and the mode was **3** marks.

In Part (a), candidates were required to draw the lateral view of a diagram of a vertebra drawn from an anterior view. This question was not very well done. Most candidates were unable to convert the view presented into an accurate lateral view. Several candidates believed that simply rotating the drawing would have provided the lateral view required. Candidates also lost marks easily because they did not provide a title, or the magnification, even though prompts were included. However, many candidates gained the marks allotted for labelling of the vertebra.

In Part (b), candidates were to identify the location of the vertebra in the spinal column based on distinguishing the characteristics shown in the diagram. This part of the question was very badly done. Candidates failed to recognise that the illustration represented a thoracic vertebra because of the long neural spine and the many-faceted articulating surfaces of the transverse processes. They thus indicated positions such as the 'neck' and 'lower back', incorrectly thinking that the diagram represented cervical or lumbar. Candidates need to pay more attention to the distinguishing features of the vertebrae that allow them to perform specific functions in the spinal column.

In Part (c), candidates were asked to relate structural features observed in the drawing of the humerus to the functions that the bone carries out. This part of the question was very badly done. Candidates referred to parts of the bone that they could not observe in the diagram such as ‘bone marrow’ and ‘cartilage’. Candidates were expected to identify parts such as the *shaft, tuberos head, groove* and *ridges*. They were then expected to relate these parts to the functions of the bone: *shaft which is elongated and cylindrical for support; tuberos head for articulation with socket for movement, groove at distal end for articulation with ulna/movement* and *ridges for attachment of muscles*. A good response was:

Projections and ridges – allow for muscle attachments to allow movement ... such as attachment of biceps and triceps for flexing and extending arm  
 Depressions and groove – to facilitate articulation with the ulna and scapula and hence create a joint which ...  
 Long, large shaft – which gives strength for support ...

### Question 3

This question tested candidates’ knowledge of biological investigations and common apparatus and methods used in these investigations. Candidate performance on this question was very disappointing and emphasised the inability of candidates to perform creditably on papers that require experimental skills, if they have not been exposed to basic biological investigations. The mean was approximately 4 out of 17 marks and the mode was 1 mark.

Part (a) of the question required candidates to assemble pieces of apparatus used to determine whether oxygen is given off during photosynthesis. Candidates did not perform well on this question. Many had no idea of the placement of the waterweed or how to collect the gas emitted during the photosynthetic process.

In Part (b), candidates were asked to write an aim for the investigation. Although a number of candidates were able to give a fairly good response, the majority were not able to provide an appropriate response. A good response provided by one candidate was: *to investigate whether oxygen is given off during photosynthesis*.

Part (c) required candidates to explain how they would be able to detect oxygen in the investigation. Candidate performance on this question was generally poor.

In Part (c) (i), candidates were asked for the observation in the collecting test tube after some time, and in Part (c) (ii), they were to explain how the information gathered would be used to support the aim.

Good candidate responses to both parts of the question were:

- (c) (i) ... the volume of water inside the test tube would decrease significantly as it becomes filled with gas.
- (c) (ii) ... light the splint with a flame, out it and place in the test tube with the gas. If the splint re-lights then oxygen is present, and the aim proven.

Part (d) described a situation in which light would have been an impacting factor on photosynthesis in a crop of plants. Candidates were asked to identify the impacting factor and design an investigation to test a suggested hypothesis. The majority of candidates were able to identify *light/sunlight* as the impacting factor in (d) (i). However, in Part (d) (ii), which required that they identify the method and apparatus that would be required to test the hypothesis, their performance was poor. Candidates were expected to use apparatus for determining the starch content/intensity, including *a solution of iodine in potassium iodide, samples of leaves exposed to different light intensities/leaves from different*

*locations, use of leaves of similar size, and age; apparatus used to prepare a leaf for the starch test. Candidates were expected to state in their method: means of preparing the leaves for the starch test and describe the starch test including colour changes.*

Part (d) (iii) required candidates to make an inference from the results obtained from the investigation. This part of the question was very badly done and leads to the conclusion that candidates do not know what an *inference* is. Candidates were expected to infer that: *if plants from the shaded area produced less starch, then those plants were undergoing less photosynthesis.* A good response by one candidate was:

Iodine should turn bluish-black on both leaves as they both have stored starch from photosynthesis. The unshaded leaf would make the colour more intense indicating more starch hence greater photosynthesis. ...

**CARIBBEAN EXAMINATIONS COUNCIL**

**REPORT ON CANDIDATES' WORK IN THE  
SECONDARY EDUCATION CERTIFICATE EXAMINATION**

**MAY/JUNE 2009**

**BIOLOGY**

## CARIBBEAN EXAMINATIONS COUNCIL

### BIOLOGY

MAY/JUNE 2009

#### GENERAL COMMENTS

The June 2009 examination in Biology at the General Proficiency level was the 34<sup>th</sup> sitting of this subject conducted by CXC. Biology continues to be offered at both the January and June sittings of the examinations. The Biology examination is one of the more popular of the single sciences offered by the CXC at the CSEC level and assessed the performance of approximately 14 000 candidates this year. The examination comprises three papers: **Paper 01 – Multiple Choice; Paper 02 – Structured/Extended Essay paper; and Paper 03, the School Based Assessment (SBA).**

The overall performance of candidates this year declined slightly over 2008. Seventy-four percent of the candidates achieved grades I – III as compared with 77 percent in 2008. Candidates were challenged by their lack of knowledge of the specifics of biological concepts, their inability to analyse data and account for trends, and to make drawings that adequately represent biological specimens. Some candidates also found difficulty recalling the names of biological processes and events. Candidates are still unable to adequately display the skills they are supposed to acquire in pursuing practical work, for example, data representation and methods of investigation. These comments relate to teaching of the subject matter and calls for students having more opportunity to express for themselves the concepts, principles and processes – writing these down and checking for accuracy as well as for engaging in practical activity, including field work, and not merely writing up experiments in note books. Further, there is insufficient attention paid to several suggestions which the Biology examiners have repeatedly made over the past years. These comments take on more meaning with the new format of the Biology examination that has eliminated choice. Particular attention must be paid to the comments reiterated below in preparing candidates, *if the desired improvement in performance is to be realized and sustained*. These comments relate both to test-taking techniques and means of addressing the content of questions:

- Teachers should remind their students that there is more to taking an examination than memorizing the content. When preparing students for an examination, time should be spent practicing *how to interpret* and answer questions clearly, concisely, and to the point.
- Candidates also waste time providing information that is irrelevant to the question. This gains them no marks. This is particularly important for the extended essay component of the paper. Candidates ought to make better use of the time allotted for reading through the paper and planning their responses *before* starting to write.
- Candidates are advised to take special note of the cues given in the questions and underline key words to draw attention to what the question requires. When the question asks for two items, many candidates give one, and lose marks unnecessarily through apparent carelessness.
- Candidates should not re-write the questions in the spaces allocated for the answers.
- Candidates should also use the question numbering as a guide to link the different parts of the question. They should note that the numbering changes when there is a change in concept or context. They should also make every attempt to use the information given in the various parts of a question to help focus the context and content of their responses.



- Biological jargon should be used where appropriate and **spelling** of biological terms **must** be correct. Spelling of common biological terms continues to be atrocious. Even when the biological term is used in the question candidates will introduce their own incorrect spelling of the term. It is not possible to award marks for incorrectly spelt terms where they actually mean something different. Candidates far too often seemed unfamiliar with the meaning of common terms used in Biology, for example, “annotate”, “adaptation”, “structural features”, “distinguish”, “precaution”, “limitations”, “factor”, “implications” or “types”. Teachers should direct their students to the glossary of terms available in the CSEC Biology syllabus.

It should be noted that candidates at this level are expected to demonstrate understanding of fundamental principles and concepts including *the relationship of structure to function in living organisms; the relationship of living organisms to their environment; the cell as the fundamental unit of living organisms; genetics and variation and their role in perpetuating species; the impact of disease on living organisms, including social and economic effects on humans, and the impact of human activity on the environment.* The Biology Team suggests that teachers should use more constructivist approaches in the teaching of Biology. This requires students to be more involved in explaining their notions, clarifying the content, and fully engaged in problem-solving activities.

It is repeated here that every effort must be made to encourage and facilitate the use of appropriate biological jargon, including the correct spelling of terms. Candidates can lose marks for incorrect spelling as the badly spelt term may take on new meaning.

The Biology Examining Committee also believes that there is very limited or no sharing of best practice in the subject area. Sharing best practices among science educators cannot be over-emphasised. In addition, advanced technology is at our disposal and the timely introduction of e-learning programmes across the region is viewed as a potentially enabling opportunity. This innovation must be embraced by all as far as possible.

### **DETAILED COMMENTS**

#### **Paper 01 – Multiple Choice**

Paper 01 consisted of 60 multiple-choice items. Performance on this paper was quite similar to that of last year's. The mean for the paper was 61 per cent, the same as for 2008.

Some of the topics that were most problematic for candidates were:

- Role of bacteria in the nitrogen cycle
- Role of ATP
- Water conservation in plants
- Identifying variables in an investigation
- Reflex arc and reflex action
- Surface area to volume ratio
- Function of the skin in humans
- Functioning of the uriniferous (kidney) tubule
- Role of hormones in the menstrual cycle
- Monohybrid inheritance
- Sex linkage
- Sampling, using a quadrat
- Soil properties

## PAPER 02 – Structured and Extended Essays

Paper 02 consisted of six questions, three of which were in the structured response format and three in the extended essay format. This paper tested the three profile skill areas identified in the Biology syllabus. All questions were compulsory. Candidate performance on this paper declined over June 2008. Candidates were able to gain marks across the range for almost all questions and the mean for almost every question was relatively close to the mid-point of the range.

Since candidates were able to generally attain marks across the allotted range for the questions, it is evident that all the marks on the paper were available and attainable. However, in order for more candidates to give their best performance, attention must be paid to the observations and suggestions the Biology examiners have repeatedly made. Observations and suggestions relate primarily to examination techniques which candidates should follow when writing this paper. In particular, candidate attention is drawn to the use of the stimulus material in responding to the questions and the guidance provided by the spaces allotted to each question where necessary.

Candidates must note that they are not required to repeat the questions to begin their responses for the first three questions on the paper. Candidates also continue to display weak practical skills especially in describing methods of experiments and in drawing conclusions from data. These observations suggest that teaching for developing practical skills must include discussions, explanations and rationalization of procedures and outcomes on the part of students, so that they become capable of developing and manipulating experiments and experimental data on their own.

Simply having students write up experiments without orally communicating what they are doing and, providing appropriate explanations for occurrences, squanders the opportunity practical activities provide for teaching and learning. In addition, too many candidates are unable to produce accurate diagrams of common biological structures and they do not observe the conventions of drawing, including giving the diagram or drawing a title, labelling neatly, using straight parallel lines, using sharpened pencils and providing the magnification.

### Question 1

This question dealt with an investigation of a small coastal ecosystem along a busy highway which was studied by a biology class. Candidates were required to demonstrate knowledge of methods used in undertaking field work, as well as of data collection and representation procedures; and their ability to interpret data and account for trends observed in historical data.

Candidate performance on this question was disappointing. The mean was approximately **9** out of **25**.

Part (a) examined candidates' knowledge of investigative methods in ecology. Candidates were required in Part (a) (i) to identify pieces of apparatus other than the quadrat that could be used to investigate the changing distribution of plant and animal species in the area under study, and in Part (a) (ii) to describe how the apparatus they identified could be used for the stated purpose. These parts of the question were fairly well done by the candidates. The majority were able to identify an appropriate piece of apparatus and to a large extent describe how it could have been used in an investigation of species distribution in the area. Candidates were generally expected to include in their responses: *rope/string; tape measure; bottles; traps and other relevant materials*.

Part (b) examined candidates' knowledge of data collection methods, data representation and analysis. In Part (b) (i) candidates were asked to give a precaution that should be taken when using a quadrat to determine species distribution. In Part (b) (ii), they were to calculate the density of one species given data presented in a table, and in Part (b) (iii) they were to give a reason why the succulent plants were found in the large numbers recorded in the table. These parts of the question were fairly well done, although many candidates omitted the units in providing their answers to the calculation. Many candidates knew that in using the quadrat they would have to make the throws randomly and repeat throws as precautionary measures. Candidates found Part (b) (iii) to be the most challenging. Candidates were expected to know that succulent plants store water which makes it readily available in a habitat that is deficient in water supply, or in which water becomes unavailable to the plant because of environmental conditions. Candidates were thus expected to indicate in their responses: *water in short supply; water availability limited; water available to their growth not suitable; succulent plants store water; they are better adapted to habitat with limited availability of water.*

Candidate responses that gained full marks were:

There may not be a high source of water in the area and so the plants have to adapt to store water to cope with the water shortage, hence their succulence.

Succulent plants are present since they receive little water near the busy highway, which accounts for their need to conserve water.

Candidates performed reasonably well on Part (c) of the question, which assessed knowledge of feeding relationships amongst a range of organisms in a pond. In Part (c) (i), candidates were asked to construct a food web guided by the feeding relationships of numerous organisms in the pond that were presented in tabular form. In Part (c) (ii), they were asked to explain why a food web usually has no more than four trophic levels and in (c) (iii), they were to identify physical factors that might affect the population of the organisms that live in the pond. Candidates were generally able to earn the marks allocated to Part (c) (i), although many candidates still placed the arrows in the wrong directions, and others did not capture the interconnectedness of food chains, characteristic in a food web. While candidates were able to earn at least one of the marks allotted to Part (c) (iii), many of them were not able to distinguish physical from biotic factors. Candidates were expected to identify factors such as: *temperature, turbidity and rainfall.*

Part (d) of the question examined candidates' knowledge and understanding of the importance and impact of studying population trends. Candidates were given data in a table on the population size of frogs over a seven-year period. Candidates were to first plot a graph of the data using the grid provided. The data provided indicated that no data was collected in one year in which there was a hurricane. Candidates read the data as though there was thus no frog population. Many candidates left a gap in the graph or put the frog population at zero. Candidates must be aware that the fact that data was not collected at a particular time does not mean that the data does not exist. The graph should be continued as normal with a straight line drawn between the data collection points. What is critical though, is that the scale should not be changed, but should reflect that there is no data collection point where none is collected. In addition, many candidates produced a bar graph, when the line graph is more appropriate for showing the continuous variation characteristic of a population size. In Part (c) (ii), candidates were to account for the trend in the frog population before and after the hurricane.

This part of the question was not at all well done. Many candidates proceeded to describe the graph rather than offer an explanation of the decline in the frog population before the hurricane and the increase and decline after the hurricane. Candidates were expected to include in their responses: (1) decline before the hurricane may be due to – *limited availability of food; killed by vehicles/humans; use of pesticides/insecticides* (2) increase after hurricane – *pond expands due to rainfall; more tadpoles/increase fertility*; (3) decline after hurricane – *competition; limited availability of food; killed by vehicles; use of pesticides/insecticides; destruction of habitat*. A good response was:

Before the hurricane the frog population was in decline because of the dry, heated and inhospitable conditions. After the hurricane wet conditions provided adequate breeding grounds/habitat for the frogs accounting for the sharp increase in the frog population. Conditions eventually grew drier after 2000, hence the population decreased from 2001 to 2004.

In Part (d) (iii), candidates were to suggest why it is useful to study the distribution of frogs. This part of the question was not very well done. At best, some candidates focused on the importance of such studies to the frog species only, and did not relate to the role of the frog population in the food web, so that monitoring of the frog population was also a means of monitoring other populations of importance to humans. Candidates were expected to include in their responses ideas such as: *good indicator species; numbers give an indication of how well the ecosystem is doing; population changes in frogs indicate changes in the environment* and that the frog population will change due to - *amount of food available; number of predators in the ecosystem; suitability of the habitat for the survival of the organisms*. Responses that earned full marks were:

It is useful because frogs are amphibians and they live in both aquatic and terrestrial environments. Therefore the migrating pattern of frogs will give us an indication of the problems affecting the environment.

Frog populations would reflect on the availability of insects as a food source, suggesting insect population distribution.

### **Misconceptions**

- Quadrats or nets could be used to determine the population of organisms in a pond.
- ‘Succulent’ plants can be sucked, rather than the plants are adapted for storage of water.

### **Question 2**

This question tested candidates’ knowledge of the structure and functioning of the human eye. Candidate performance on this question was as anticipated with those who knew the material obtaining full or near to full marks, while those with only a passing familiarity with the subject scored low. Once more it is stated that candidates often seem to perform worse than expected on questions that require specific knowledge of familiar biological content – concepts, principles and processes. However, candidates were able to access marks across the range with their performance showing a mean of 7 out of 15. Several candidates indicated that they ‘know’ the material, but cannot recall correctly the names of structures and definitions. This relates to teaching of the subject matter and calls for students having more opportunity to express for themselves various aspects of the content – concepts, principles and processes – writing these and checking for accuracy.

Part (a) of the question required candidates to label certain structures identified in a diagram of a longitudinal structure of the human eye. This part of the question was only fairly well done even though this is a common part of the Biology syllabus. Candidates too often failed to correctly name the parts of the eye, referring to the *iris* as the *cornea* and the *fovea* as the *blind spot*, and other similar errors. Candidates also tended to be loose in distinguishing the *ciliary muscles* and *suspensory ligaments* referring to them as the 'ligaments' or 'muscles', which could not earn them marks. In Part (d) (i), some candidates named the corrective lenses, but did not note the label to which they referred, and thus lost marks that they otherwise might have gained.

Part (b) asked candidates to give the biological term for rods and cones given that they are specialized cells stimulated by light. This part of question was not very well done. The expected response was *receptors /sense cells*.

In Part (c), candidates were asked to explain how a severe lack of Vitamin A might affect a person's ability to see. This part of the question was not very well done. Candidates were expected to focus their responses on: *passage of light through cornea becomes blocked; cornea needs to be transparent; could cause blindness/impaired vision*. A good response to this part of the question was:

The cornea is responsible for the refraction of light. When it is dry and thickened refraction becomes more difficult and the object observed cannot be focused on the retina to cast the image resulting in the person's inability to see.

If the cornea is dry and thickened, light would not be able to refract correctly on the lens and would not be able to focus on the retina

In Part (d), candidates were given some diagrams illustrating common eye defects and corrective lenses. In (d) (i), candidates were to identify the illustrated eye defects and match the corrective lens with the defect. This part of the question was reasonably well done. Candidates were expected to: *distinguish between long-sightedness and short-sightedness and link the diagram of the convex lens with the correction of long-sightedness and the concave lens with correcting short-sightedness*. Many candidates knew the names of the lens that corrected each defect, but failed to identify which of the three lenses in the diagram should be used to correct the defect, and thus failed to earn the allotted marks. In Part (d) (ii), candidates were asked for precautions to be taken when using contact lenses. This part of the question was quite well done. Candidates were generally able to make reasonable and accurate suggestions including: *washing of hands before applying; washing lenses in antiseptic lotion*.

### Question 3

This question required knowledge of the structure and functions of a green plant, in particular, the internal structure of a dicotyledonous leaf, transport within the plant, and aspects of conservation of water. This is another popular component of the Biology syllabus and was generally familiar to candidates. However, as for questions about specific topics in Biology, their knowledge of specific details was often lacking. The mean was **6** out of **15**.

Part (a) of the question asked candidates to give a function for which the leaf is suited and indicate how it is in fact suited to the named function. This part of the question was well done. Candidates appropriately referred to a number of functions including, photosynthesis, respiration and transpiration. They also appropriately referred to the leaf being broad, thin and flat, to trap sunlight,

the possession of chloroplasts for light absorption, stomata and sub-cellular air spaces for gaseous exchange.

Part (b) of the question focused on candidates' knowledge of the leaf structure and function. In Part (b) (i), candidates were to show, using three arrows only, the path of water diffusing from the leaf on the diagram provided. This part of the question was not well done. Far too many candidates had little idea of the diffusion pathway of water molecules in the leaf which should have shown movement from: *spongy or palisade mesophyll to the sub-stomatal air spaces through the stoma*. In Part (b) (ii), candidates were to identify the two structures labeled on the diagram. These structures were the *vascular bundle/xylem* and *stoma*. This part of the question was well done. However, candidates need to know that stomata refer to more than one 'stoma'. In Part (b) (iii), candidates were to give one consequence to a herbaceous plant if there is a temporary unavailability of water to replace that given off in transpiration. This part of the question was not at all well done. Candidates were expected to refer to the fact that under this condition of stress, *stoma closes; wilting occurs*. Many candidates stated that the plants become flaccid. Note that this term describes the condition of plant cells that have lost water and not the entire plant, which in fact shows 'wilting'. A well-stated response was:

The plant will stop photosynthesising and wilt and could eventually die.

Part (c) of the question examined candidates on their knowledge of transport in plants. In Part (c) (i), they were asked to explain how water from the soil gets to the leaf in a plant. This part of the question was fairly well done. Candidates were expected to indicate that *water is absorbed by the root hairs; diffuse across cells of root cortex; xylem takes water from the root cortex/water diffuses into the central xylem; forces act to move water upwards in xylem/capillarity/root pressure/transpiration pull; diffusion from xylem to leaf cells*. A response that gained full marks was:

Water from the soil diffuses into root hairs along a concentration gradient, and travels in the transpiration stream due to transpiration pull and capillary action. Water travels up the xylem in xylem sap and thus diffuses into cells in the leaf of the plant, where it is used in photosynthesis and metabolism.

In Part (c) (ii), candidates were to explain how any named structural feature of plant cells helps in transport within plants. This question proved challenging, especially for less able candidates. Candidates were expected to refer to structures such as: cell wall - *thin walls that allowed diffusion of materials*; narrow, conducting vessels, for example xylem - *hollow tubes for capillarity to allow water to move upwards; hollow tubes/ continuous columns/no end walls to facilitate transpiration pull*. Responses that gained full marks were:

The xylem vessels are long and elongated. Also, they are dead, without contents and walls are made of lignin. Because they are dead and hollow there are no obstructions, thus, there is free movement of water from the root to the leaves.

Plant cells have partially permeable cell membranes, which allow certain substances to enter and leave the cells. This aids in the transport of nutrients and water to the different parts of the plant and in transport of waste materials out of the plant.

Part (d) asked candidates to explain why all the water taken up by the roots of a plant is not lost by evaporation from the leaves. This part of the question was very poorly done. Candidates' responses were expected to develop on ideas such as: *use of water in photosynthesis; use in other metabolic processes; constituent of protoplasm/vacuoles*. A response that earned full marks was:

Some of the water taken up by the roots is used in photosynthesis (in the light dependent stage) and some is used in the activation of enzymes for metabolic reactions. Thus, only some water evaporates.

### **Misconceptions**

- Plants become flaccid – the correct concept is that plant cells become flaccid.
- Water diffuses through the waxy cuticle.
- The processes of osmosis and diffusion are the same.
- The term 'semi-permeable membrane' is no longer used. The correct term is 'selectively permeable' membrane.
- Gaseous exchange and transport in plants are different.

### **Question 4**

This question assessed the depth of candidates' understanding of the structure of the kidney tubule and the ways in which its functions are affected under specific conditions. The question also assessed candidates' knowledge of xerophytic conditions and the ways in which plant functions may be adapted to suit those conditions. The performance was weak. The mean was **5** out of **15**. Candidate weaknesses were observed to be: inability to provide accurate drawings; to recall the structure and function of a common biological organ; as well as applying their knowledge of biological events to a particular context or situation.

Part (a) of the question dealt with the structure and functioning of the kidney tubule. In Part (a) (i), candidates were asked to draw a diagram of the kidney (uriniferous) tubule, and explain how urine is produced and gets to the bladder. This part of the question was fairly well done, although several candidates produced poor diagrams in which the major structures were not accurately represented, or they drew a diagram of the gross structure of the kidney. Some candidates drew the gross structure and included a minute diagram of the uriniferous tubule. Candidates need to follow the instructions of the question and do only what is asked. They are not credited for providing irrelevant information. Too many candidates seem unfamiliar with the common biological practice of annotating diagrams and drawings. Annotations are notes on the drawings themselves which are neatly placed to support the labels and usually give the function of the labeled parts. In Part (a) (ii), candidates were required to suggest why urine production is important in humans. This part of the question was fairly well done. Many candidates did not obtain all the marks allotted to the question as they did not provide a comprehensive enough response, citing only one of the functions of urine production. The following is an example of a response that earned full marks:

Urine production is important in humans because it filters the blood and allows excess water, salts and urea to be excreted from the body. If there is too much water in the blood, cells would take in excessive amounts of water and if it is not secreted the cells will swell and burst. If there is too little water in the blood, the cells can become plasmolysed and die. The kidneys help in osmoregulation.

Part (b) of the question assessed candidates' knowledge of how the body deals with an excess of water presented in the context of the activities of a Boy Scouts troop going on a hike. Candidates who recognized the immediate homeostatic response of the body to maintaining water balance in the blood were able to describe the response to excess water in the blood, including the role of the hypothalamus. Too many candidates believe that when one takes in water, the body simply sweats to reduce the excess. Candidates were expected to refer to the: *role of the hypothalamus, reduced production of anti-diuretic hormone; reduction of re-absorption of water by the kidneys; increased production of watery urine and elimination from bladder*. Good candidate responses to this part of the question were:

The hypothalamus senses that blood is too dilute when the blood is passing through it so it sends a message to the pituitary gland to secrete less anti-diuretic hormone, thus lowering the permeability of the walls of the distal convoluted tubule and the collecting ducts, lowering the amount of water reabsorbed. Large amounts of dilute urine is produced and the blood returns to normal concentration.

... his hypothalamus gland will control the release of anti-diuretic hormone (ADH) in such a way to allow less water to be reabsorbed into his bloodstream via the kidney so that the excess water is passed out with his urine.

In Part (c), candidates were to give reasons why plants growing along a hiking trail had mechanisms to reduce water loss. A good candidate response to Part (c) was:

(1) Given the inclination of the mountain there will be a lot of water runoff and plants will have to adapt to the lack of water available. (2) There will be a lot of wind blowing up the mountain which will increase the rate of transpiration (water loss) from the plants.

For the trail to exist, it had to be cut which removes overhead foliage. The direct sunlight increases temperature which would increase transpiration rates.

The trail has the tendency to be very hot during the day. The hot air above the trail rises and the cool air rushes in causing breezes made by convection currents. These winds move saturated air from around the leaf bringing drier air. This could increase the transpiration rates and more water could be lost.

The plants were in an ecosystem where water was sometimes scarce and unavailable and thus needed to conserve any available water for later use. The plants were in a very hot, windy environment which favours transpiration and so to prevent too much water from being lost, they had mechanisms for conservation.

This may be due to the absence of a constant water supply. This area may also be very windy and hot which encourages very rapid transpiration rates. To avoid these conditions plants adapt to conserve the little water they receive from time to time.

The plants on the trail have mechanisms for reducing water loss because:

(1) The plants are growing on a hillside which means that when it rains, water quickly runs down the hill. With necessary adaptations (long and wide growing roots), the plant will be unable to acquire sufficient water for sustenance and photosynthesis.



(2) Also, the plant on the trail may not receive a sufficient amount of water each day, for example, those at the summit of mountains (water flows faster down from the top.)

They need special mechanisms to trap water ... the hill may be very windy which will increase transpiration of the small amount of water contained in the plant. The plant is adapted to such circumstances.

### **Misconceptions**

- Animal cells become turgid. It should be known that 'turgidity' is a plant concept.
- Sweating is part of the mechanism for controlling the water concentration in the blood.
- 'Ureter' and 'urethra' mean the same.
- Urine comes out of the uterus.
- Excess water is released through respiration or sweating.
- ADP/ATP/ADH are interchangeable terms.
- The function of urine is for pregnancy testing.

### **Question 5**

This question required knowledge of the carbon cycle and the impact of human activity on changes in the levels of atmospheric carbon dioxide, consequences of such changes, and ways of controlling carbon dioxide levels in the atmosphere. Candidate performance on this question reflected a mean of 7 out of 15.

Part (a) of the question required candidates to show how named processes are involved in the recycling of carbon in nature. This part of the question was not particularly well done. While many candidates were able to either name relevant processes or describe aspects of the processes, far too many failed to address the issue of the *recycling* of carbon. Candidates were expected to show in their responses how the processes that they identified contributed to the recycling process relevant to carbon. The question asked for an illustration using a diagram. Just stating the processes was inadequate. Many candidates failed to make a link between the process that fixed carbon dioxide into organic compounds (photosynthesis), and those processes that either released carbon dioxide back into the atmosphere (respiration, combustion, decomposition), or further integrated them within living organisms (feeding).

Part (b) of the question examined candidates' knowledge of the impact of human activity on natural cycles and the consequences of these activities. In Part (b) (i), candidates were required to suggest ways in which human activity contributes to an abnormal rise in the level of atmospheric carbon dioxide. This part of the question was fairly well done. Candidates were expected to include in their responses reference to: *deforestation, overuse of fossil fuels, industrialization and or agricultural practices*. A good response was:

Burning of fossil fuels: Car exhaust from the burning of fossil fuels increases the carbon dioxide content in air. Also, factories and industries increase the amount of carbon dioxide.  
Deforestation: Humans deforest for lumbering purposes, development, housing or cultivation/agriculture. Trees reduce the amount of carbon dioxide in the atmosphere, therefore, cutting the trees down decreases the amount of carbon dioxide being absorbed by the trees thereby increasing the carbon dioxide concentration in the air.

Part (b) (ii) followed on from the first part of the question by asking about the consequences of an abnormal rise in carbon dioxide levels on ecosystems. Candidates were mostly familiar with the range of possible consequences of increased carbon dioxide levels in the atmosphere and performed well on this part of the question. Candidates correctly included in their responses: *warming of the atmosphere/climate change; melting ice caps/rising sea levels; organisms adapted to cool climates may die; some areas become drier and infertile; plants that thrive on extra carbon dioxide will flourish*. Good candidate responses were:

One likely consequence of abnormally high carbon dioxide levels on ecosystems is that plants would thrive if they also had a supply of water and sunlight, but the animals would suffer from oxygen deprivation leading to weaker young from breeding ... lower chances of survival. The producers in the ecosystem would thrive but the consumers would suffer, especially carnivores, which depend on other animals being plentiful in numbers for food.

One likely consequence of abnormally high carbon dioxide levels on the ecosystem is the removal of certain species of animals and plants from the ecosystem due to global warming. Global warming is the increase in temperature of the earth's atmosphere due to absorption of heat by the increased concentration of greenhouse gases such as carbon dioxide. This rise in temperature can cause changes in the habitats of some animals (for example, glaciers melting, polar bear population decreasing). This can cause the extinction of species. Also, some populations of plants and animals cannot cope with the slightest change in temperature, therefore, through global warming these organisms can die out and be removed from the ecosystem. Hence, organisms which feed on these organisms are affected and so the entire ecosystem is affected. Biodiversity decreases.

Part (b) (iii) asked candidates to suggest ways in which the levels of atmospheric carbon dioxide can be controlled. This part of the question was also well done, with most candidates gaining the marks allotted. Good responses were:

Carbon levels can be controlled by (1) the use of alternative sources of energy which are efficient, cleaner and safer for the environment. One such form of energy is ... ethanol to power vehicles in Brazil. The vehicle emissions from the ethanol do not pollute the atmosphere or the environment. Other alternative sources of energy include solar, wind, wave and geothermal energy, geothermal being ... earth's volcanic energy. (2) when areas are deforested for development, trees and other plants should be re-planted in another area. When trees are cut down for lumber the area should be reforested. Policies and laws should be introduced that control the number of acres of land being deforested per year and governments should reserve portions of land devoted to preserving the ecosystems there. This would help ensure that the carbon dioxide levels ...

Reafforestation/Afforestation reduces the high levels of carbon dioxide in the atmosphere by the absorption of carbon dioxide by plants for their life processes (photosynthesis). Reduce burning of fossil fuels. More organic fuels can be used like biogas and ethanol.

### Misconceptions

- Global warming cause depletion of the ozone layer.
- The term ‘carbon dioxide’ is interchangeable with carbon.
- Carbon dioxide destroys the ozone layer.
- Perfumes and sprays destroy the ozone layer and increase the amount of carbon dioxide in the atmosphere.

### **Question 6**

This question assessed the depth of candidates’ knowledge of the structure and function of the human female reproductive system. The mean was 7 out of 15.

Part (a) addressed candidates’ ability to draw an outline of the human female reproductive system and provide the functions of selected components. In Part (a) (i), candidates were asked to show on a diagram the relative positions of specific, given parts of the female reproductive system. While most candidates earned the marks allotted to this part of the question, several lost marks because they misrepresented various components, for example, they presented the ovary as continuing from the fallopian tube including a cavity, or the uterus and cervix as one continuous indistinguishable walled cavity. Candidates are to be reminded that their diagrams must accurately represent the biological structures. In Part (a) (ii), candidates were asked to annotate the diagram to identify the functions of the labelled parts. This part of the question was only fairly well done. A very large number of candidates did not appear to know the meaning of the term “annotate”, and as for Question 4, provided extensive notations in prose after the diagram instead of labelling the parts and giving their functions on the diagram itself. There were, also, problems in labeling, in that the convention of labelling to one side then the other of the diagram with adequate space for the annotations were often not done. The result was very untidy and unclear diagrams. Candidates were expected to include in their labels the following functions: *ovaries for ova production/ production of hormones – oestrogen and progesterone; oviduct for passage of ovum/site of fertilisation; uterus for implantation of the embryo/development of the embryo and cervix – ring of muscles that closes lower end of uterus/dilates for passage of baby during birth.*

Part (b) examined candidates’ knowledge of the female reproductive cycle and the impact of certain factors on the developing foetus. In Part (b) (i), candidates were to pose likely consequences of limited production of oestrogen and progesterone. This part of the question was generally well done, as candidates associated limited production of these hormones with lack of development of secondary sexual characteristics, the inability of the female to have a regular menstrual cycle and to properly prepare for pregnancy. Candidates’ responses in a variety of ways reflected anticipated concepts: *no development of secondary sexual characteristics; irregular menstrual cycle; inability to become pregnant or unsuccessful pregnancy.* A good response was:

With limited production of oestrogen, there would be no ovulation since the peak in oestrogen during the menstrual cycle stimulates the release of an ovum from the ovaries. Also, the uterus lining would not be able to thicken properly since these are the two hormones responsible for this and, thus, the girl would not be able to conceive and have a baby.

In Part (b) (ii), candidates were asked to identify ways in which smoking might harm the developing foetus. This part of the question was well done. Candidates often cited the role of carbon monoxide in reducing the oxygen-carrying capacity of the blood, thus reducing availability to the foetus. They suggested that this could result in *underdeveloped babies/low birth weight/increased chances of still births*. They also made claims to the role of nicotine as being able to cross the [placenta resulting in addicted babies that could show withdrawal symptoms at birth. A good response was:

... Cigarette smoke contains many harmful chemicals such as nicotine and carbon monoxide. These chemicals are able to pass over into the foetus' blood system via the placenta. Nicotine causes the narrowing of arteries and thus the foetus' arteries would constrict increasing the blood pressure inside the foetus. Since the foetus has very delicate tissues, high blood pressure can lead to the rupturing of these tissues and thus death of the foetus. ... [c]onstriction of arteries also reduces the oxygen-carrying capacity of the blood. Carbon monoxide, too, reduces the oxygen-carrying capacity since it combines irreversibly with haemoglobin to form carboxyhaemoglobin. This would lead to the foetus' tissue not getting enough oxygen to respire to get energy to develop and the baby can be born physically or mentally retarded and is usually premature.

Part (c) of the question assessed candidates' knowledge of reproductive health. In Part (c) (i), candidates were to give one disadvantage of using condoms. This part of the question was very well done. Candidates indicated that *condoms were not 100 percent effective; were not used correctly* or that *users required psychological adjustment/preparation*. Part (c) (ii) asked candidates to offer reasons why choosing a birth control method can be more difficult for the female partner in a marriage. This part of the question was also very well done. Candidates cited a range of reasons that were anticipated in their responses, including: *the female is the only one who gets pregnant; they are more susceptible to contracting STDs; their fertility might be affected/side effects from methods; discomfort with certain methods*. A good response to this part of the question was as follows:

This is because (a) the birth control methods for a female's use often deal with the insertion of some foreign object into the vagina or even an injection. These methods are uncomfortable and sometimes painful, and (b) one birth control method is tubal ligation. This process is irreversible ... and she may not want to make this final decision ... when men can easily just put on a condom which is painless.

## Paper 03 – School-Based Assessment

### GENERAL COMMENTS

Performance on the School-Based Assessment was commendable. Favourable trends that continue to be observed include: good syllabus coverage (that is, a minimum of nine syllabus topics covered) by most centres; an increase in the number of centres where both quantitative and qualitative fieldwork were done, and the number of times practical skills were assessed generally complied with syllabus guidelines. This suggests that most teachers recognize the value of providing sufficient opportunity for students to develop and master all the specific practical skills. However, while the skill of Observation, Recording and Reporting (ORR) was generally well done, Drawing (Dr), Analysis and Interpretation (AI) and Planning and Designing (PD) continue to present candidates with the most difficulty.

While the level of organization and presentation of books submitted from most centres was good, there were still some centres that submitted books without the requisite information. The CXC Biology syllabus (page 44) provides guidelines for candidates' preparation of practical books for submission. Some important requirements often **NOT** met include: a Table of Contents with aims of the practical activities, page numbers, dates, and a clear and specific indication of the activities used for SBA and the skills being assessed. In addition, the marks awarded for each practical activity must be placed along with the practical, and not simply listed at the front or back of the books.

The lack of comments in the practical books, especially for skills performed poorly, suggests that students are not being given adequate feedback on their progress throughout the period of study. Often times, only ticks are observed, and the final score awarded for the skills, but students appear unaware of their strengths or deficiencies.

The moderation exercise was often hampered by poor mark schemes. Teachers are being reminded that mark schemes must be legible and preferably bound together instead of on loose sheets of paper. There must be a clear and direct relationship between the marks awarded to the appropriate activities in the practical books and the marks on the tally sheets. It should also be noted that no more than two skills should be assessed in a practical activity. New teachers in particular should consult pages 38 – 44 of the Biology syllabus for guidance in preparing and presenting mark schemes.

The following is a list of criteria which teachers should follow in marking SBA activities:

- Marks should be awarded for each skill separately. It is noted that in some cases, marks were given for each skill, then tallied to give a composite score. This is unacceptable.
- Marks awarded to students' work should be a fair indication of its quality. Too many students received high marks for work that fell short of the CXC standard. This was particularly noticeable for Planning and Designing, Analysis and Interpretation, and Drawing. When the CXC standard is not observed there is great disparity between the teacher's score and that of the moderator. This circumstance is usually **disadvantageous** to the candidates.
- Marks submitted on the moderation sheet should reflect the candidates' marks in each of the samples. Consistency of marking and submission of marks relate to the reliability of the process and thus the acceptability of marks submitted.

- Teachers are once again reminded that body fluids such as saliva, blood and urine are not to be used for practical work. These can be sources of infection and may have serious legal implications should a student become infected while conducting practical work. Plant materials must be removed from books before they are submitted to CXC, since these are also potential agents of infection when moved from place to place.

The Examining Committee would also like to recommend that there be greater cooperation among teachers of similar subjects at the same centre and mentoring of new teachers, to ensure consistency in standards is maintained.

A review of previous schools reports will provide additional suggestions for developing practical skills. Further suggestions are reiterated in this report and each teacher is alerted to the specific strengths and weaknesses displayed by their candidates in the Moderation Feedback Form sent to schools from CXC, after moderation. The moderation feedback form, which is sent to each centre, provides constructive and useful information relevant to the particular teacher(s). This form offers specific recommendations and is intended to assist teachers in planning, conducting and assessing practical work – in the laboratory and field. Improvement of students' practical skills will have a direct influence on candidate overall performance in the Biology examination, since certain questions, notable Question 1 on Paper 02, are based on knowledge and application of these practical skills.

### **SPECIFIC COMMENTS ON THE ASSESSMENT OF SKILLS**

The following information is to assist especially new teachers of Biology in interpreting the information given on the CXC Moderation Feedback Report.

The number of times a skill is assessed is considered sufficient if assessed a minimum of 4 times (see page 37 of the Biology syllabus).

#### **Observation, Recording, Reporting (ORR)**

This skill appears to have been mastered. For most centres sampled, the method was clearly described with logical sequence of activities. It was also observed that except for a few centres, the past tense was correctly used in the presentation of the report on the practical activity (except for Planning and Designing, as required). Candidates should be encouraged to give careful attention to grammar, quality of expression, and giving as much details as possible when reporting their procedures and observations, as science students need to appreciate the importance of clarity in explaining their results. Where possible, students should also be encouraged to repeat procedures and give average results to improve the reliability of their results.

The tables and graphs were usually clear and provided adequate details which allowed for clear description and discussion of the experiment. The Examining Committee recommends that teachers give more activities where students construct their own tables and graphs using their results. This will allow them the opportunity to develop these skills.

When using tables, teachers should remind candidates that the TITLE should be written above the table using CAPITAL LETTERS, the table must be enclosed and appropriate row and column headings should be given.

**Example:**

TABLE 1: FROG POPULATION OBSERVED FROM  
OCTOBER 1997 TO OCTOBER 2004

Year	Number of frogs
2004	5
2001	110
1997	125

When using graphs the TITLE should be written below the graph and underlined; axes should be labelled, with units stated and a key should be presented if necessary.

If calculations are required, all necessary calculations should be shown and these should be done and presented neatly and in an organized fashion. Units should also be included where necessary.

Where drawings are used in reporting observations, they should meet standard SBA drawing criteria, although the skill is not being assessed.

**Drawing (Dr)**

The quality of drawings of candidates from most centres has shown some improvement, especially in relation to clarity of drawings. However, at too many centres poor drawings were awarded high marks. The Examining Committee does not expect drawings to be works of art, but they should meet the criteria for accuracy, clarity, labelling and magnification. Teachers should ensure that students are given several opportunities to practise and develop drawing skills.

It is a requirement that drawings must be practised from actual specimens and not from textbooks. Specimens MUST include drawings of **flowers, fruits, storage organs and bones**. Additional examples may be included in practical books. However, **microscope drawings, models and apparatus should not be used for SBA assessment**. Drawings of cells, while useful for teaching, should not be assessed at this level, but if taught, the calculation of magnification should also be emphasized. Similarly, dissections may help students to understand structures such as the digestive system but they are too complex to be drawn accurately at this level. These difficult drawings do not provide a fair test of ability at this level.

Table 2 is a list of ‘Do’s’ and ‘Don’t’s’ applicable to SBA biological drawings:

**TABLE 2: DO’S AND DON’T’S OF BIOLOGICAL DRAWINGS**

<b>Do’s</b>	<b>Don’t s</b>
<ul style="list-style-type: none"> <li>• Use pencils for all Drawing activities – drawing, label lines, labels</li> <li>• Use drawings of actual biological specimen (not diagrams, models or textbook drawings); ensure for assessment there are drawings of flowers, fruit, seeds and bones</li> <li>• Let the size of drawings be at least half page</li> <li>• As far as possible, have label lines and labels positioned at right side of drawing</li> <li>• Let all label lines end at the same vertical plane</li> <li>• Let label lines be drawn parallel to the page top/bottom</li> <li>• Ensure label lines end on part being made</li> <li>• Write TITLE using CAPITAL LETTERS</li> <li>• In title, use the word “drawing” and not “diagram”</li> <li>• Position title under the drawing and indicate the actual name of the specimen (for example, cervical vertebrae of a goat, mango leaf, hibiscus flower) and the view drawn</li> <li>• Underline the title</li> <li>• Include the magnification and state, where appropriate, actual length and width of specimen as well as place ‘x’ in front of the magnification</li> <li>• Write magnification to 1 decimal place</li> <li>• Use a key to explain symbols where appropriate, for example, stippling/cross hatching</li> </ul>	<ul style="list-style-type: none"> <li>• No arrow heads</li> <li>• No crossing of label lines</li> <li>• No dots or dashes</li> <li>• Do not join letters of words for label or title</li> </ul>



Accuracy and labelling continue to be problematic for candidates and there appears to be some degree of inconsistency - even among teachers at the same school - in how they are assessed. Label lines should be drawn with a ruler and as much as possible, labels should be written in script (not capitals) so that they can be easily read. Annotations should give the functions and descriptions of the structure where appropriate. Annotations that accompany drawings should be as brief as possible and clearly and neatly written.

The Examining Committee also encourages teachers to ensure that standard drawing criteria are applied whenever drawings are required in practical activities, especially when reporting observations and/or illustrating biological processes, for example, germination, regardless of whether DR skills are to be assessed or not. This should help students appreciate the importance of the skill.

Teachers should also ensure that students draw on plain paper and then neatly insert drawings into practical books, if the books are not designed with plain sheets of paper for drawing. Distinguishing features and labelling lines are oftentimes unclear when drawings are done on ruled sheets of paper.

### **Analysis and Interpretation (AI)**

This skill continues to present problems for the majority of candidates. Many teachers continue to use questions to stimulate discussion. This device is good for helping students to develop their AI skills. However, they should not be used excessively, nor should they be the only means of assessment. These questions must guide students to provide the required background information, give explanations for the results, draw conclusions and show an awareness of possible limitations. The information provided in this way should then be written up as a paragraph of continuous prose as is normally done for the discussion/ conclusion. In many cases, candidates seem to have learnt a formula for writing up the discussion but showed no real understanding of how to interpret their own results. As a learning strategy, teachers may ask their students to orally explain the results to obtain a clearer view of their understanding and to help them develop their analytical skills.

The marking criteria used by some teachers did not include ‘limitations’ as one of the criteria. It was sometimes observed that precautions/control/sources of error were often accepted as limitations by the teacher.

The use of controls should also be emphasized in discussions as they are a point of comparison for the experimental set up in which a particular variable has been omitted. This comparison should be included in the discussion as it is the key to drawing the conclusion. Conclusions should relate directly to the aim of the investigation. Students should also be reminded to discuss at least one limitation of the investigation. It is important for them to recognize that the conditions present in a school laboratory are rarely ideal.

The processes involved in demonstrating the AI skill are reiterated here:

- Background information may be written in the “Discussion,” or in the introduction section.
- Background information for the experiment must be related to the theory.
- Discussion should be an analysis or interpretation of the recorded experimental results. Discussion must not simply answer posed questions for AI:
  - a. questions may be used to guide students but answers must be written in paragraph format (without the questions or written comprehension style)
  - b. questions should not to be included in the lab report.

- Conclusion must be based on the aim. (It is a brief answer to the aim.)
- Limitation(s) should be included among the AI marking criteria as they are very important to practical activity.
- Identifying source(s) of error and precaution(s) is necessary, as is knowing that these are both different from each other and from limitation(s)
- All components of AI (background knowledge, explanation of results, limitations and conclusion) should be included in the mark scheme for the skill.

The Examining Committee is again reminding teachers that food tests on their own are not appropriate for assessing AI. Simple investigations can be designed in which food tests are used. For example, students can be given unknown mixtures and asked to find out which food would be most suitable for an infant. Food tests can be used also to determine the presence of a particular food before and after digestion by an enzyme. These types of exercises will allow students to develop the necessary skills. Knowledge of the food tests and the nutritional requirements can then provide the background information on which they will base their conclusions.

### **Manipulation and Measurement (MM)**

As has been the trend in previous years, this skill continues to be the one that most candidates appear to have achieved mastery of, based on the observation that most are awarded full marks. However, evidence such as performance on the practical question in the final examination suggests that these marks may not be the result of rigorous marking. Also, if virtually all students in a class gain full marks on an activity, this suggests that the task may not be demanding enough, or the criteria not detailed enough, to allow the necessary discrimination between different levels of performance.

The Examining Committee recommends that teachers expose students to a wide range of apparatus and their use in collecting data. This would help to ensure candidates' manipulation skills develop and allow for a more fair assessment of students' competence in MM.

### **Planning and Designing (PD)**

Performance on this skill has shown some improvement relative to former years and teachers should be commended for demonstrating more creativity in the types of observations/problem statements provided to students on which to base their hypotheses and design their experiments. The Examining Committee continues to emphasize the importance of using examples from students' local environment, as this will help students better appreciate how they can apply their biological knowledge and practical skills to solve problems they frequently encounter. Teachers are reminded that it is inappropriate to have students copy procedures from textbooks and reproduce them verbatim for assessing students' PD skill.

The experiments designed by the students from some of the centres moderated, indicated that there was some understanding of the procedures involved in planning and conducting an experiment but in some instances, there were no replicates in the investigations. There were still a few areas of difficulty where candidates were unable to state their hypotheses clearly and relate the aim to the hypothesis. A hypothesis is a theory based on particular observations, about how things work or why something happens.

It is also important that development of the skill start with the commencement of the teaching of the syllabus. In many cases it was obvious that practical activities targeting the development of the Planning and Designing skill was among the last set of activities in which the candidates engaged

prior to the examinations. Figure 1 is an example of how a planning and designing activity might be effectively developed.

**Example:**

This Planning and Designing activity submitted by one centre was based on the observation that “*A boy notices that all the trees around his yard except the grapefruit tree were infested with ‘duck’ ants*”. The students were required to plan and design an experiment to determine what was responsible for the difference in infestation. An example of an appropriate hypothesis and a relevant aim for investigating the hypothesis was:

***Hypothesis:** ‘Duck’ ants do not feed on grapefruit trees because the leaves contain a chemical that repels the ants.*

***Aim:** To find out which plant leaves ‘duck’ ants feed on  
(The aim of the subsequent investigation could be: *To determine the presence of chemical X in different leaves.*)*

There was a clear description of the materials and method. Students planned to use different leaves to see if the duck ants would respond as they do the grapefruit leaves. The ‘duck’ ants would then be placed in labeled containers containing the same number, sizes of leaves taken from a particular tree. A container with no leaves was an appropriate control. The measurable variable would be the number of ‘duck’ ants that leave or remain in each dish. Results would then be tabulated and subsequently discussed.

As stated by the candidates, one limitation may be that ‘the chemical in the leaves that cause the effect on the ‘duck’ ants may be affected by the extraction’. Appropriate marks were awarded for the various aspects of the experiment.

**Figure 1.** Example of a good Planning and Designing activity

**CARIBBEAN EXAMINATIONS COUNCIL**

**REPORT ON CANDIDATES' WORK IN THE  
SECONDARY EDUCATION CERTIFICATE EXAMINATION**

**JANUARY 2010**

**BIOLOGY  
GENERAL PROFICIENCY EXAMINATION**

## GENERAL COMMENTS

The January 2010 sitting of the CXC examination in Biology consisted of three papers on which all questions were compulsory. The papers were as follows:

- Paper 01 – Multiple Choice
- Paper 02 – Structured/Essay Questions
- Paper 03/2 – Alternative to School-Based Assessment (SBA)

As in the previous year, performance of candidates in this examination was as anticipated, particularly performance on Paper 02. Performance on Paper 03/2 was again disappointing and highlighted the lack of practical experience, inadequate development of required biological skills and insufficient practice. Also contributing to weak candidate performance was the lack of attention to test-taking techniques and suggestions made by the examining committee which have been made repeatedly and which have been further embellished and detailed. These suggestions are reiterated hereunder because of their critical importance to future candidates of the Biology examination:

- Candidates must improve their test-taking skills. This includes practice in reading questions carefully and planning responses so that answers are organized in a logical and coherent manner.
- Candidates continue to waste a lot of valuable time supplying irrelevant information in the essays even though guidance has been provided in the spaces allotted regarding expected responses. Candidates should focus on key words such as ‘describe’ and ‘explain’ when reading the questions and be guided by the mark allocation and quantitative descriptors within the text of the question as far as possible.
- There was also the question of choice of terminology and descriptions provided. Familiarity with biological jargon allows candidates the opportunity to express themselves more accurately and reduces errors caused by oversimplification.
- Candidates should pay more attention to the stimulus material provided in the questions, especially in the first three questions on Paper 02 and on Paper 03/2. They did not use the stimulus material to answer the questions or, as happened in Paper 03/2, referred to experimental activities outside of that requested. The stimulus material is meant to guide candidates to the expected responses. Candidates too often responded by providing obscure information in their responses that did not relate to the scenario presented, or they ignored the obvious in favour of little-known phenomena.
- More emphasis should be placed on practical skills and candidates’ ability to demonstrate these skills in responding to questions on Paper 03/2. Too many candidates seemed unfamiliar with basic laboratory equipment and material and even the simplest of biological/scientific methods. Candidates demonstrated particular weakness in stating aims and in describing methods of the commonest of experimental activities, for example, transpiration investigations.
- The spelling of common biological terms is generally so poor that candidates cannot be rewarded with marks. It is also difficult to explain why candidates would incorrectly spell biological terms that are actually used in the question.
- Candidates also showed a decided lack of appreciation for and understanding of biological jargon they are expected to know and use at this level. Terms like ‘physical factors’ and ‘adaptations’ have specific meanings for biologists.

- Candidate preparation for the examination requires a comprehensive knowledge of the syllabus content and an ability to use the information to address biological issues.

### **Paper 01 – Multiple Choice**

Paper 01 consisted of 60 multiple choice items. Performance on this paper was similar to that of last year's. Some of the topics that *continued to be* problematic for candidates were:

- Aspects of ecology, including feeding relationships and food chains
- Cell structure and function
- Specifics of photosynthesis
- Specifics of respiration
- Cell specialization
- Morphology of root, stem and leaf
- Gas exchange
- Reproduction in plants
- Aspects of nutrition, for example, the role of different vitamins
- Aspects of respiration and excretion
- The functioning of sense organs
- Metabolic rate and effect on the body temperature

### **Paper 02 – Structured/Essay Questions**

Paper 02 consisted of six essay questions, three of which followed the short-answer format while the other three were more extended in structure. The first question, which carried the heaviest weighting, 25 marks, was the data analysis question which assessed candidates across all profiles - Knowledge and Comprehension, Use of Knowledge and Experimental Skills.

Candidates were able to attain marks across the allotted range for only one of the six questions. For more candidates to give their best performance, attention must be paid to observations and suggestions the Biology examiners have repeatedly noted. In particular, candidate attention is drawn to the use of the stimulus material in responding to the questions and the guidance provided by the spaces allotted to each question - answers should relate to the stimulus material and should be kept within the allotted spaces. In addition, in preparing for the examination, all topics on the Biology syllabus must be studied and adequately prepared. It was quite obvious that inadequate attention was paid by this candidate population to segments of the Biology syllabus, including flower structure, seed and fruit dispersal and experimental activities, such as choice-chamber investigations of invertebrate behaviour.

Candidates must note that they are not required to repeat the questions to begin their responses for the first three questions of the paper. This usually takes up the space allotted for the answer.

Candidates sometimes missed key words in the questions and provided answers which were off the point. It is thus suggested that candidates should be advised to read through each *question carefully, highlighting key words on which the questions hinge, so that they would be less likely to misread and misinterpret questions*. Candidates also continued to misspell common biological terms, for example, *epidermis* and *dermis*.

### Question 1

This question dealt with some practical aspects of Biology, including methods of investigating the behaviour of selected invertebrates under certain physical conditions, data analysis, and plant responses to light and gravity. Candidate performance on this question was satisfactory. Marks were accessed across most of the range, though no candidate scored the two highest marks available for the question. The mean was approximately 9 with a mode of 8.

Part (a) of the question required candidates to assemble pieces of apparatus used to create a choice-chamber for investigating the behaviour of invertebrates (house-fly larvae) in response to light. Many candidates were unable to accurately assemble the apparatus given and this underscores the candidates' lack of exposure to, and experience with simple biological investigations.

Part (b) assessed candidates' ability to interpret experimental data as well as their knowledge of investigating the behaviours of invertebrates. Candidates generally displayed weak knowledge and skills in this regard.

In Part (b) (i), candidates were to complete a table by making calculations based on data provided. Most candidates were able to do the calculations, though many made simple arithmetic errors.

In Part (b) (ii), candidates were to determine, based on the information provided, whether the hypothesis of the investigation was supported and to provide a reason for their response. This part was fairly well done as a fair number of candidates were able to indicate that most of the larvae were found on the dark side of the apparatus. While some of the candidates were able to suggest at least one factor, other than light, that could have influenced the response of the larvae in their response to Part (b) (iii) of the question, many could not suggest the two factors expected - *moisture* and *temperature*.

Further, Part (b) (iv), following on from Part (iii), required candidates to suggest how the apparatus might be adjusted to investigate one of the factors that they had identified and was very badly done on the whole, even though the candidates were able to identify a correct factor. Candidates were also expected to indicate the *separation of the choice-chamber into dry and moist areas using silica gel and water*, or *keeping one side at a lower temperature, perhaps using ice on one side* or some such adjustment that illustrated a mechanism for the chamber to be set up, so that the organisms choose one area over another.

Part (b) (v) was fairly well done, in that most candidates were able to gain at least one mark as they were able to cite that the response shown by the organisms could help them escape predation. However, few candidates mentioned prevention of *desiccation* which was an acceptable response.

Part (c) of this question examined candidates' knowledge of plant response to sunlight. In Part (c) (i), candidates were to explain how the response to sunlight illustrated in the diagram benefitted the plant. This part of the question was reasonably well done. Quite a few candidates were able to make the link between the response and improving the photosynthetic process. Candidates were expected to include among their responses: *maximal exposure to light*; *keeping the rate of photosynthesis at a maximum throughout the day* and *palisade layer (leaf) at best angle to obtain light throughout the day*.

In Part (c) (ii), candidates were to describe an experiment to determine whether a potted plant had been photosynthesizing. A good response to this part of the question was:

*A starch test can be used; leave the plant in a dark area for 24 hours to rid it of starch, and then place it in the sun for an hour. Take a leaf; dip it in boiling water to soften it, then in ethanol to rid it of chlorophyll, then again into boiling water. Next, drop iodine solution on the leaf and note the resulting colour change.*

Candidates performed creditably on Part (c) (iii) of the question which asked for conditions other than light that are necessary for photosynthesis. Candidates generally selected from among the expected responses: *carbon dioxide, water and chlorophyll*.

Part (d) of the question explored candidates' knowledge of the response to gravity shown by germinating seedlings. In Part (d) (i), candidates were asked to suggest why, in such an investigation, the seedlings in the control were constantly rotated. This part of the question was fairly well done. Candidates included in their responses such ideas as: *for even distribution of auxins* and *effects of gravity evenly distributed*. A good response was: *This is an important step because the constant rotation allows for even distribution of auxins (growth hormones in the plant)*.

Part (d) (ii) asked candidates to explain why the response to gravity was important for the survival of the plant. Many candidates were unable to relate the response to the proper orientation of the plant with the roots responding positively to be able to access water, mineral salts and nutrients, and the shoot responding negatively to obtain light for photosynthesis.

Responses that earned full marks were:

- *Gravity helps roots grow into the ground to absorb water and necessary nutrients. However, shoots should grow against the pull of gravity in order to receive sunlight. Photosynthesis will be able to occur and plants will survive.*
- *The response to gravity is essential because the roots need to grow into the soil for water and to anchor the plant while leaves and stems need to grow up for light to photosynthesise.*

## Question 2

This question tested candidates' knowledge of the structure and functioning of the alveolus and other aspects of the human lung, relevant to its efficiency as an organ of gaseous exchange. Candidate marks ranged from 0 to 14 out of a maximum of 15. The mean for this question was 5.1 and the mode was 4.

Part (a) of the question examined candidates' knowledge of the structure of the alveolus and the movement of gases across its membrane. In Part (a) (i), they were asked to label specific parts of a diagram of a section through an alveolus. This part of the question was only fairly well done. Many candidates seemed not to know that the alveolus has an inner lining of moisture and thus could not identify this on the diagram. In Part (a) (ii), candidates were required to identify the gases that were indicated by arrows placed on the diagram. This part of the question was fairly well done.

Part (b) of the question addressed aspects of gaseous exchange across the alveolus. In Part (b) (i), candidates were asked to name the process by which the gas moves across the alveolar membrane. Many candidates recognized that this process was *diffusion* but fewer were also able to identify one feature shown in the diagram that made the alveolus suitable for this process. The diagram clearly showed that the alveolar membrane was *thin* — just *one cell thick*. Some candidates indicated that the balloon shape increased the surface area for diffusion and were awarded the mark.

Part (c) asked candidates about the role of breathing in the movement of gases into and out of the alveolus. This part of the question was not at all well done and it may mean that candidates are unclear about the meaning of the term 'role'. In many cases, candidates provided explanations about respiration which were not related to the movement of the gases. Candidates were expected to include in their responses: *breathing moves air in and out of alveoli; air coming in has high oxygen and low carbon dioxide concentration; air leaving has low oxygen and high carbon dioxide*.



Part (d) of the question asked candidates to give reasons why a person who is exercising vigorously breathes more deeply and rapidly. Candidates were expected to include in their responses references to: *the need for more energy; the need for more oxygen; oxygen debt; build up of carbon dioxide*. A response that earned full marks was:

- *To supply a sufficient amount of oxygen which is needed to release more energy which will be utilized during strenuous activity.*
- *To repay the oxygen debt and get rid of the lactic acid formed during exercise so it will be broken down.*

Part (e) asked candidates to explain how cigarette smoking reduces the efficiency of the lungs. This part of the question was not well done. Candidates were expected to include in their responses ideas that related to the reduction of the surface area of lung for gaseous exchange, such as: *tar/smoke particles clog alveoli; coughing ruptures alveoli; frequent infections and destruction of the alveoli; possibility of lung cancer*. Good responses were:

- *This can cause the lining of the lungs, to be broken down, also cause the lung to have a smaller surface area for gaseous exchange and also cause lung cancer.*
- *Cigarette smoking can reduce the efficiency of the lungs because the tar it contains would clog the walls of the lungs thus diffusion of the oxygen would not be efficient since the surface area is reduced.*

### Question 3

This question tested candidates' knowledge of fruit and seed dispersal. Performance on this question was poor. Many candidates seemed unfamiliar with the concept of 'adaptation' of fruits and seeds for dispersal. Candidates' scores ranged from 0 to 13 out of a maximum of 15; the mode was 0 and the mean was 2.6.

Part (a) of the question tested candidates' knowledge of structure of the fruit and seed. In Part (a) (i), candidates were required to provide labels for some common structures of fruit and seed and for a structure that is peculiar to the fruit. This part of the question was not very well done. Most candidates seemed unaware that the fruit is attached to the plant at the receptacle which leaves a scar. Some candidates referred to the scar left by the style which was at the other end of the coconut fruit shown in the diagram. Also, candidates labelled 'radicle' when the lines pointed to both radicle and plumule. The appropriate term in that case was *embryo*. Similarly, the cotyledon and endosperm should have been labelled *food store*. In Part (a) (ii), candidates were to give the function of the food store. They were expected to know that the food store *provides nutrients for the germinating embryo*.

Part (b) of the question examined candidates' knowledge of dispersal in fruit and seed. In Part (b) (i), candidates were required to name a method of dispersal for the red bean and the coconut. Candidates were generally able to gain at least one of the marks, as they knew that the coconut was dispersed by water. They were more challenged in providing an accurate method for the red bean. Either one of *explosive mechanism, self or mechanical method was an acceptable response*.

In Part (b) (ii), candidates were to suggest features of the coconut shown in the diagram that are important in dispersal. Candidate performance was weak in this part of the question. They were expected to consider: *flotation device, food store and size*. Candidates often only mentioned the flotation device. Part (b) (iii) was even more challenging for candidates and was thus very poorly done. Candidates were asked to explain why coconut trees are usually found along the coastline of islands while red bean plants are found inland. Candidates were expected to explain that: *waves carry*

coconut fruits to shorelines, they lodge there, have best opportunity to germinate; red bean is a domesticated crop/cultivated by man, normally planted inland. An example of a good response was:

- Coconut trees are mostly found at coastline areas because the waves bring in coconuts from other places to the shore where they germinate; red bean plants are found inland because people plant them.

Part (c) investigated candidates' ability to distinguish features that relate to the dispersal of fruit and seed as illustrated in photographs of a fruit before and after dehiscence. In Part (c) (i), candidates were asked to identify the method of dispersal illustrated. This part of the question was fairly well done. Many candidates indicated *self* or *explosive mechanism*. In Part (c) (ii), candidates were to suggest why plants were usually found growing in clusters around the parent plant illustrated in the diagram. The responses were expected to include: *dispersal method involves self-explosion of the dry fruit; seed not dispersed very far from the parent plant*.

#### Question 4

This question examined candidates' knowledge of the process of photosynthesis, aspects of translocation in plants; conditions under which plants store food and the importance of 'green spaces' in built communities. Candidate performance on this question was fairly good. There was general familiarity with the topics and candidates were able to gain marks across the spectrum from 1 to 15. A number of candidates were unable to gain any marks at all. The mode was 3 and the mean 5.2.

In Part (a), candidates were to describe the process of photosynthesis. Many candidates were unable to provide an adequate description of the process. Some were unable to clearly define the roles of light and chlorophyll or ignored these factors completely. Others did not show evidence that they knew the source of reactants, carbon dioxide and hydrogen, nor the name of the product glucose, providing instead the term carbohydrate which was given in the question. A good response was:

*The process is called photosynthesis. It is represented by the equation:*

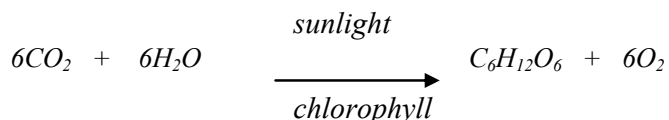

*This process occurs in two stages — the light-dependent stage and the light-independent stage. In the light-dependent stage, the water molecules are split into hydrogen and oxygen using sunlight energy. The oxygen molecules are released as a gas. After this, is the light-independent stage, when hydrogen molecules reduce carbon dioxide molecules forming glucose (carbohydrates).*

Part (b) of the question asked candidates to explain how non-green structures in a large tree obtain food materials for their livelihood. Candidates were expected to include in their responses such ideas as: *manufactured food from leaves would be supplied through phloem; food transported as sugar/sucrose; mineral salts transported from roots via xylem — used in protein synthesis*.

Part (c) asked candidates to suggest factors or conditions which determine whether plants store either very little or very much of the food they make. This question proved challenging for candidates and few provided adequate responses. Candidates were generally expected to refer to: *length of the growing season; climatic conditions, stages in the life cycle of the plant; soil factors — water availability, fertility*. Good responses were:

- *Factors or conditions which determine whether plants store very little or very much food are if the plant is reproducing and needs to make and disperse seeds it would have to store a lot of food for energy. If the plant is young it needs to get a lot of energy by having good food storage. Also, if the plant is seasonal and faces hard conditions such as drought or winter...*
- *If the plant is in an environment where all factors for photosynthesis are close to their optimum state, not much food will be needed to be stored since there is a constant supply produced due to the favourable conditions.*
- *Little food will be stored when the plant is growing since most of it will be needed at growth areas and as a result of growth more food will be produced.*
- *When the plant is ready to reproduce, stored food results in the production of fruits and flowers ...*

Part (d) asked candidates to outline reasons for leaving green spaces within crowded cities even when there is a shortage of land for housing and industrial development. This part of the question was fairly well done, although some candidates had difficulty expressing themselves adequately. Good responses to this part of the question were:

- *Three reasons for leaving 'green spaces' are so that the trees take in carbon dioxide ... from the cities and make oxygen, a useful product of photosynthesis which we need for a vital life process, respiration, to make energy. Also the 'green lands' may provide cross-pollination of plants, some may be for medicinal purposes. 'Green lands' also provide a habitat for animals so that they may continue their species.*
- *Three reasons for leaving these 'green spaces' are to reduce global warming; allows for recreation within cities and also leaves habitats for wild life, for example, birds. Global warming can be reduced since the green plants/trees absorb carbon dioxide for photosynthesis. If these plants were not there, there would be an excessive amount of carbon dioxide in the air which leads to global warming. These parks may be used for recreation, for example, children playing on swings and slides, that is, for enjoyment. Having woodlands enables the development of habitats, for example, birds and squirrels. If these 'green spaces' were not there then this may lead to extinction of some species.*

### Question 5

This question tested candidates' knowledge of the structure and function of the human digestive system, aspects of diet and modifications to the vegetarian diet, endocrine functions relative to food digestion and deficiency diseases in plants. Candidates were able to gain marks across most of the range from 1 to 14, even though several candidates did not score at all. Performance on this question was reasonable. The mean for this question was 5.3 and the mode was 4.

Part (a) of the question dealt with the structure and functioning of the alimentary canal as well as some issues related to special diet. In Part (a) (i), candidates were required to draw a diagram to show the relative position of the major organs of the human digestive systems and for Part (a) (ii), they were to annotate the diagram to show the functions of the labelled parts. These parts of the question were fairly well done, although a substantial number of candidates did not know the relative positions or functions of the major organs of the digestive system. Candidates need to be better prepared to follow the instructions of the questions. Candidates displayed poor drawing skills in preparing the outline required.

In Part (a) (iii), candidates were asked to suggest how vegetarians can make up for any limitations associated with their diet. This part of the question was fairly well done. Candidates were able to zero in on the *limited availability of protein* in such diets and means of compensating for protein deficits through the inclusion of *legumes*, such as *peas* and *beans* in their diets. Many candidates, however, failed to mention *varying the diet* to include sources of *minerals and vitamins* and using dietary supplements which are also important in ensuring a balanced vegetarian diet. A good candidate response was:

- *Vegetarians can compensate for their lack of proteins by using milkshakes or taking tablets that boost the proteins in their body as they do not get protein from meat as regular omnivores do. Certain vitamins also, like vitamins B and D which come from animals, vegetarians could get pills with those vitamins.*

Part (b) investigated candidates' knowledge of the endocrine functions of the pancreas by asking how the removal of the pancreas would affect this function. This part of the question was only fairly well done. Candidates' responses were expected to include ideas such as: *no insulin produced; no conversion of sugar to glycogen; need to eat constantly to provide energy; no regulation of the blood sugar; onset of diabetes; presence of sugar in the urine*. The following responses earned the candidate full marks:

*If the pancreas is removed, there would be no means of the body getting insulin ...when needed. If the blood glucose level is too high insulin is secreted to lower it. If the blood sugar is too low ... glucagon is secreted to boost the level. Removal of the pancreas would definitely cause diabetes — either hypo or hyperglycemia.*

In Part (c), candidates were to explain how deficiency diseases are likely to arise in plants. This part of the question was only fairly well done. Many candidates incorrectly associated deficiency disease in plants with the *unavailability of sunlight* and thus the inability to photosynthesise and not to the lack of minerals. Candidates were expected to describe concepts including some of the following: *absence of minerals from soil/soil lacks water for mineral uptake; minerals from soil needed to make several compounds/structures in plants; examples — nitrogen/sulphur to make protein; magnesium/iron for chlorophyll; phosphorus for ATP; calcium for cell wall*. Good candidate responses to this part of the question were:

- *Deficiency disease may arise in plants if they don't have all the essential nutrients in soil. Essential nutrients are nitrogen, phosphorus and potassium. A lack of nitrogen can lead to leaves yellowing and a lack of phosphorus would lead to root weakness.*
- *Plants do make their own food but need other nutrients which they get from the soil. Nitrogen in the form of nitrates is in the soil, phosphorus ions and potassium ions as well. Without these the plant will suffer root problems, poor shoot growth and poor fruit production respectively.*

### Question 6

This question dealt with the structure of unspecialized plant and animal cells; features of a nerve cell and adaptations of organisms to their environment. The mean was approximately 3.5 and mode 0. Candidates earned scores in the range of 0–12 out of a maximum score of 15.

Part (a) of the question required candidates to draw and annotate diagrams of unspecialized plant and animal cells to compare their structures. Candidate performance on this part of the question was weak. Many candidates were unable to draw an adequate representation of the plant cell to show the relationship between the cell wall and cell membrane and the vacuole. Candidates were expected to make reasonably accurate representations of the two types of cells and show that they both had the

following: *cell membrane, cytoplasm, nucleus and mitochondria* while only the plant cell had a *large central vacuole, chloroplast and a cell wall*.

In Part (b), candidates were required to identify features of a nerve cell that allowed it to carry out its function. Performance on this part of the question was weak. Few candidates were able to gain full marks for this part of the question. Candidates were expected to frame their responses using ideas like: *elongated axons for passage of impulses, branching dendrites cover a larger area; myelin for insulation; synapses and neurotransmitters*.

Part (c) dealt with adaptations by organisms for living in a particular habitat. Both parts of this question were very poorly done by candidates. Candidates displayed very limited understanding of the concept of 'adaptation'. They apparently thought that animals could adapt almost immediately to new environmental conditions or situations of stress. The idea must be conveyed that adaptations are usually the result of survivors having structures and/or processes that allow them to survive changed conditions and the establishment of those characteristics in future generations.

In Part (c) (i), candidates were required to identify physical factors that animals in a freshwater habitat encounter. This part of the question was not very well done as many candidates seemed unclear about physical factors. Candidates were expected in their responses to refer to the following: *excessive amounts of water; oxygen availability/unavailability; fluctuation in tides/variable water levels; change in environment/turbidity, nutrients/pH*.

In Part (c) (ii), candidates were to suggest adaptations that animals in a freshwater pond might have and offer an explanation of the usefulness of the adaptation to the organism. This was very poorly done. Apart from being unclear about the meaning of adaptation, candidates who mentioned a reasonable adaptation failed to indicate how this was beneficial to the organism. A good response was:

*... fresh water organisms also produce a large quantity of dilute urine since in fresh water there is little or no salt, and the organism would not have a good balance of salts in its blood stream. This ensures correct salt concentration in the fish.*

### **Paper 03/2 – Alternative to SBA**

This paper assessed all the practical skills required of biology students. Candidates continued to display weak practical skills especially in aspects of planning and designing, including manipulating apparatus, describing methods of experiments and in drawing conclusions from data. These observations indicate that teaching for developing practical skills *must include actual experimenting and investigating scientific phenomena, discussions, explanations and rationalizing of procedures and outcomes*, so that candidates become capable of developing and manipulating experiments and experimental data on their own. Also, candidates continued to display weak drawing skills and lack of knowledge of the conventions of biological drawings, such as the inclusion of magnification and titles of the drawings. In addition, many candidates presented untidy drawings with crooked labelling lines.

#### Question 1

This question tested a range of candidates' experimental skills as would be required in undertaking an investigation of a range of organisms in their environment. Performance on this question was satisfactory although no candidate achieved marks at the top of the range. The mean for this question was approximately 7.6 out of 18 available marks, while the mode was 8.

Given a table of data showing a range of organisms and their estimated populations in a habitat, candidates were required in Part (a) to identify methods by which the information shown could have been gathered. Candidates were expected to choose from methods such as: *bottles, nets, traps*,

*Tullgren funnel, quadrats and counts.* Many candidates mentioned line transect which is typically used across obviously uneven terrain, for example, across terrain with a stream or river.

In Part (b), candidates were to explain how two of the methods they identified would have been used to collect the information. This part of the question showed that many candidates, even though they could identify a method, had no idea how to use it. For example, while some candidates mentioned bottles, they indicated that the bottles could be placed near the nest of the organism with bait to attract them, when in fact *bottles are to be placed with tops at the level of the ground overnight so that nocturnal organisms can randomly fall into them.* The point being made here is that there are techniques in using the methods and Biology students need to be familiar with these methods and techniques, preferably through practice and experience. In addition, the question asked *how* the methods were likely to be used, but many candidates described *where* the methods could be used, suggesting the need for greater attention to be paid to the question asked.

Part (c) of the question required candidates to construct a bar graph to show the relative population sizes of selected organisms from the table. The most common error candidates made was to use a histogram instead of a bar chart. This reflects on the candidates' lack of understanding of how discrete data are represented as compared to continuous data. Also, candidates are reminded that in presenting graphical data straight lines should be used for purposes of accuracy.

Part (d) asked candidates to identify organisms that were likely to be at the same trophic level and to offer an explanation for their choice. This part of the question was fairly well done. Candidates were often able to correctly identify pairs by the size of their population as was expected. Some indicated that such population were unlikely to prey on each other, for example, snail/slug; iguana/kiskedee.

Part (e) asked candidates to offer an explanation as to why a pyramid of numbers may not have been appropriate to show the feeding relationships between the tree and the organisms it supports. They were expected to include in their responses ideas contained in one of the following: *mass of the tree versus its number; organisms at lower trophic levels have larger numbers in a pyramid; one tree supports many organisms; numerous herbivores.*

## Question 2

This question tested candidates' ability to make observations and carry out investigations on diffusion and the rate of transpiration in plants, including the assembling of relevant apparatus. The mean score was approximately 7.6 out of a total of 25 and a mode of 9.

In Part (a), candidates were required to demonstrate knowledge of experimental skills related to an investigation of movement of water in plant tissue. While candidates were able to attain some marks on this question, it was clear that there were many gaps in their understanding.

In Part (a) (i), candidates were to provide an aim for the investigation illustrated by the apparatus. Candidates generally found difficulty stating an appropriate aim for an investigation. Candidates were expected to suggest an aim, for example, *to show diffusion of water across plant tissue.* Many aims consisted of a description of the process rather than the end result.

Part (a) (ii), which required candidates to explain the results of the investigation after 20 minutes, was fairly well done. Most candidates recognized that water entered the potato 'cup' and dissolved the salt crystals it contained. Their greater challenge came in accounting for the movement. Very few candidates recognized that a concentration gradient was formed with movement from high to low water concentration. Candidates were thus expected to include in their responses: *diffusion from surrounding cells; water moves along a concentration gradient; salt crystals help establish gradient (low concentration).* A good response was:

*The salt placed in the cavity caused the water concentration to decrease this meant that the water outside had a higher concentration ... water moved along this concentration gradient via osmosis through the plant tissues to inside the cavity until the concentrations outside and inside that cavity were the same.*

In Part (a) (iii), candidates were asked to suggest precautions that should be taken in carrying out the investigation on diffusion. Many candidates were able to gain the relevant marks for this section. Candidates were expected to indicate precautions from the following: *no punctures in cucumber cup; epicarp completely removed; water does not spill into the cup before the start of the investigation.* A candidate response that obtained full marks was: *make sure the cucumber is healthy so that none of the tissue is damaged; make sure inside the cucumber is dry at the start of the investigation.*

Part (a) (iv) asked candidates to describe how a control for the investigation may be set up. The vast majority did not earn marks on this part of the question. Candidates were expected to describe a method in which: *salt would be excluded; all other conditions would remain the same including the preparation of the cucumber.* A good response was presented as follows: *A control for the investigation would include the same as the investigation but without the salt.*

In response to Part (a) (iv), which asked how the control would confirm the results of the investigation, many candidates again failed to provide a suitable answer. Candidates were expected to focus on: *presence of no/little water in the control after the same period of time.* A candidate earning full marks worded his/her response as follows:

*If after 20 minutes no significant amount of water was seen in the cavity then the water flowed due to a concentration gradient.*

In Part (b) of the question, candidates were to make a drawing of a cross-section of the cucumber from a stereodiagram of a half of the cucumber. Candidates generally displayed poor drawing skills and equally important did not observe many of the drawing conventions. These are reiterated here:

- Use only sharpened pencils with points. Drawings should not be done in ink.
- Clarity of drawings relate to the size and technique for drawing lines. Lines should be of even thickness and drawings should be of reasonable size.
- Drawings should include magnification which should be as accurate as possible.
- Drawings must have a title that indicates the view of the specimen being drawn.
- Drawings must be accurate line representations of the specimen.
- Drawings should **not** be shaded.

Part (c) investigated candidates' experimental skills through an investigation of certain water relations in plants. In Part (c) (i), candidates were to assemble apparatus illustrated for an investigation of water uptake in a plant. This was another example of too many candidates demonstrating limited knowledge of common biological investigations and lack of associated practical skills. Candidates were expected to draw a diagram showing: *water in the measuring cylinder; root immersed in the water and shoot exposed; rubber bung sealing measuring cylinder, with Vaseline as a sealant spread over the rubber bung and mouth of cylinder.* Apart from numerous inaccuracies in the assembling of the apparatus, many candidates also omitted the title and magnification.

For Part (c) (ii), candidates were to prepare a table to record the data to be collected at two-hour intervals for the investigation. Most candidates were able to construct a reasonable table. However, there were often obvious omissions, for example, the title and the units in the headings. Sometimes candidates used a most inefficient method of recording the interval changes. This table would have been best configured with 12 columns and two rows.

### Question 3

This question tested candidates' ability to manipulate, represent and interpret health information data. Candidate performance on this question was fair. The focus of the question was on data representation and interpretation skills. The mean was approximately 7.8 out of 17 and the mode was 8.

Given a table of reported AIDS cases in Caribbean countries over a period of years, candidates were to construct graphs of the data. This part of the question was fairly well done; most candidates could plot reasonably accurate graphs. However, many candidates plotted one or two graphs when data were given for three. They are reminded that for graphs, charts or diagrams they should include a title.

In Part (a) (ii), they were to draw a conclusion from the data and graphical representation. The major error candidates made in this part of the question was to provide a description of trends rather than a conclusion. They were expected to conclude: *incidence increased sharply in the early years; incidence first occurred in male; incidence in females increased faster than males in the latter years.*

In Part (b) (i), candidates were to prepare a pie chart of data on the methods of transmission of reported AIDS cases. In preparing a pie chart candidates must:

- Accurately compute the relative proportions of each category using a total of 360°.
- Use a compass to prepare the outline of the chart.
- Use a protractor and ruler to accurately construct the segments of the pie.
- Label each segment/ use a key to identify respective segment.
- Include a title.

In Part (b) (ii), candidates were to suggest a social implication of all the data presented on the incidence and transmission of AIDS. This part was very poorly done as it appeared that candidates made no distinction between an 'implication' and a 'conclusion'. Many of them stated from the data the group that had the highest transmission rate. Candidates were expected to make references to ideas like: *behaviours of heterosexuals may be contributing to incidence of AIDS; large numbers of persons are not aware that they have contracted the disease; people need to be more aware; homosexuality may not be responsible for incidence.* A good response provided by one candidate was: *Heterosexuals need to refrain from having unprotected sexual intercourse because this can lead to costs for the government and to a lot of deaths.*



**CARIBBEAN EXAMINATIONS COUNCIL**

**REPORT ON CANDIDATES' WORK IN THE  
SECONDARY EDUCATION CERTIFICATE EXAMINATION**

**JANUARY 2011**

**BIOLOGY  
GENERAL PROFICIENCY EXAMINATION**

**Copyright © 2011 Caribbean Examinations Council  
St Michael, Barbados  
All rights reserved.**

## **GENERAL COMMENTS**

The January 2011 sitting of the CXC Biology examination consisted of three papers — Paper 01: Multiple Choice Paper 02: Structured/Extended Essay and Paper 03/2: Alternative to SBA.

The overall performance of candidates this year exceeded that of 2010 with candidates scoring across the full range of marks in most questions. Improvements seen in the performance on Paper 03/2 was especially encouraging, since in previous January sittings candidates consistently demonstrated poor practical skills which suggested that they had limited or no practical experience.

The poor spelling of important biological terms continues to be problematic. This sometimes prevents otherwise good candidates from being rewarded with marks and needs to be emphasized by teachers preparing candidates for these examinations.

The examining committee once again reminds candidates to pay careful attention to the stimulus material in each question which is meant to guide them in providing the correct response.

## **DETAILED COMMENTS**

### **Paper 01 – Multiple Choice**

Paper 01 consisted of 60 multiple-choice items. Performance on this paper was quite similar to that of 2010. Some of the topics *most* problematic for candidates were:

- Pyramid of numbers
- Cell structure
- Excretion in plants
- Signs of deficiency diseases in plants
- The role of auxins in plant growth
- The functions of different parts of the brain
- Communicable diseases
- Role of white blood cells in immunity

### **Paper 02 – Structured and Extended Essays**

Paper 02 consisted of six compulsory questions; three of which were in the structured-response format and three in the extended-essay format. Most candidates were able to score marks across the range for almost all questions.

#### Question 1

This question tested all three profile areas identified in the Biology syllabus — Knowledge/Comprehension, Use of Knowledge and Experimental Skills. Candidate performance on this paper was also better than performance in January 2010.

Part (a) tested candidates' knowledge of food storage sites in a flowering plant and their ability to conduct food tests. Candidates had little difficulty naming either the roots, stems, leaves, fruits or the seed as food storage sites in a flowering plant but in a few cases, the petals/sepals and stigma were sometimes incorrectly named. Some candidates were unable to state two food nutrients stored in these organs that humans use as food. They were expected to name any two of the following: carbohydrates, proteins, fats, vitamins or minerals in order to be awarded all the marks.

In Part (b), candidates were given the results of a series of food tests on a plant storage organ and asked to describe the method used to carry out each of the tests and the conclusion for each test. Candidates who were awarded full marks were those who carried out the instructions and gave a detailed description of how they would have performed the Benedict's/reducing sugar test, protein and starch tests on a sample of the plant organ. These candidates also provided the correct conclusion.

Candidates had most difficulty obtaining the four marks allocated to Part (b) (ii) because their responses did not give an adequate explanation about why the food organ tested should be included in the diet of a teenage boy. Candidates scored marks if their response stated that a teenage boy is growing and carbohydrates/sugars/starches in the storage organ provide energy for this process and that proteins present provide the material needed to build new tissues or repair tissues. Some candidates mentioned that it was a good source of fibre and were awarded marks.

Part (b) (iii) was well explained as most candidates were able to tell that feeding on the storage organ *only* meant that other nutrients, namely proteins, vitamins or minerals were likely to be lacking in the food. This would cause malnutrition in the form of deficiency diseases. Excess consumption of sugars would cause malnutrition in the form of over-nutrition and related problems such as overweight/obesity.

Part (c) tested candidates' ability to identify the presence of fats in the storage organ. The grease spot test was described accurately but the correct procedure for carrying out the emulsion test was not well known. One common misconception among several candidates was that the sample of the organ should be heated either before or after alcohol is added, which is not the case. In addition, candidates often did not state the expected results of the emulsion test, which is a cloudy white precipitate or appearance.

Identification of the storage sites in the human body was problematic for many candidates who suggested that food is stored in the stomach or other part of the gut, instead of naming the liver, adipose/fat cells under the skin or muscle tissue.

## Question 2

The first part of this question tested candidates' knowledge of the differences between the structure of a typical plant and animal cell and the function of the mitochondrion and chloroplast. Most candidates were able to gain full marks for Part (a) but some lost marks for incorrectly stating that mitochondria are absent from plant cells.

Part (b) of the question consisted of illustrations of the appearance of a plant cell and an animal cell at the start of an investigation and after one hour. Candidates were generally able to state that the process that caused the change in the appearance of both cells was osmosis.

In response to the importance of osmosis to plant cells, candidates were awarded marks for answers such as distributing water to cells, providing a medium for metabolic reactions, dissolving materials or keeping the cells turgid.

In Part (b) (iii), candidates were asked about the usefulness of turgidity to plants and most were able to correctly state that plants gain support and are kept upright when cells are turgid. A common misconception was that turgidity provides plant cells with protection.

Part (iv) required that candidates explain why animal cells burst (but plant cells do not) when taking in a lot of water after one hour. Most candidates were able to state that the presence of the cell wall in plant cells exerted internal pressure that prevents bursting. Animal cells have only a cell membrane which is unable to withstand the pressure within the cell, as it fills up with water. An error that was repeatedly mentioned by some candidates was that the cellulose cell wall makes it hard for substances to go into and out of cells and that the plant cell has more than one cell membrane.

Candidate performance on this question was fairly good. It is recommended that teachers use a practical approach to reinforce the teaching of osmosis in preparing students.

### Question 3

Part (a) required that candidates identify the trophic level of organisms found on a Poui tree using information about their food/prey presented in a table. Most candidates scored full marks for successfully completing the table. A few candidates had difficulty naming fungi and bacteria as decomposers. Some responses indicated that there is a need for teachers to clarify the definitions and differences among microorganisms, saprophytes, scavengers, fungi, bacteria, detritivores, single-celled organisms and the relationships among them, and explain their importance to organisms in a food web.

Parts (c) and (d) dealt with the survival of organisms and physical factors affecting the size of a population. In answering the question on the survival of organisms in ecosystems, candidates were able to gain marks for listing the characteristics of living organisms, for example, growth and locomotion. However, the survival mechanisms that were anticipated included adaptations, competitions, reproduction, protection and support.

Candidates' responses to Part (d) generally correctly identified soil pH, temperature, climate and some candidates indicated water availability but physical factors and physical features were used interchangeably, and physical contact among organisms and death were sometimes incorrectly stated as physical factors. Teachers need to emphasize the distinction between biotic and abiotic/physical factors.

### Question 4

This question examined candidates' knowledge of the circulatory system, aerobic versus anaerobic respiration and similarities between xylem and blood vessels.

Part (a) (i) required that candidates use a diagram to illustrate the circulatory system (heart, blood vessels, body tissues linked with each other) and describe how oxygenated blood from the lungs is distributed to organs and tissues. Many candidates were not awarded marks because they only drew a diagram of the heart without appropriate annotations and/or illustrating that oxygenated blood flows into the left side of the heart via the pulmonary vein

from the lungs. Blood vessels were sometimes incorrectly labelled and the fact that the aorta branches into smaller arteries and eventually capillaries that take blood in close proximity to the tissues was not often mentioned.

In Part (a) (ii), candidates were required to explain how oxygen becomes available to muscle tissue for respiration. They were awarded marks if they explained that blood in capillaries contributes to tissue fluid formation and oxygen dissociates from haemoglobin, moves into tissue fluid then diffuses along a concentration gradient between tissue fluid and cell across the cell membrane.

Responses to Part (b) were poor. Some responses suggested that candidates thought that aerobic referred only to exercise and fitness. Candidates lost marks if they confused both processes and the consequences of lactic acid production were not known.

Most candidates were able to score at least half the marks for Part (c) for explaining that both xylem in plants and blood vessels in humans carry water and dissolved minerals. Less frequently mentioned was the fact that both form a continuous tubular network within the organism; both are hollow or that both have walls of variable thickness that are resistant to internal pressure. Some candidates incorrectly stated that xylem vessels store foods and transport sugars.

#### Question 5

This question examined candidates' knowledge of communicable diseases in both humans and plants and the control methods used to combat the disease in each case. Candidates were further required to list the social and economic consequences of the control method suggested for the plant disease.

Most candidates were able to gain marks for identifying a communicable disease in humans but many were unable to name the pathogen responsible for causing the disease and instead named the vector. A common error was the mosquito being named as a pathogen of diseases such as malaria and dengue. The distinction between a vector and a pathogen needs to be clarified by teachers when preparing students.

In Part (b) (i), most candidates understood how vaccines work to build immunity and included the following points:

- Weakened or dead form of pathogen injected or taken orally
- White blood cells (lymphocytes) detect antigen and produce antibodies which destroy the antigen
- Memory cells are formed that respond quickly on subsequent exposure to the pathogen.

A common misconception was that vaccination was used to control bacterial infections. Emphasis needs to be placed on the difference between treating viral and bacterial infections.

For Part (b) (ii), a common response to reasons why vaccines may not have the desired effect was that the patient may have already contracted the diseases and may have a compromised immune response. Others mentioned a bad, expired batch of the vaccine.

When the allergic response was mentioned it was usually not well explained. Some candidates mentioned mutation of the pathogen and were awarded marks.

In Part (c) (i), candidates stated that the healthy-looking crop plants may also have been infected without showing any visible symptoms, hence the reason for destroying the whole crop. Generally, candidates failed to mention that the plants may all be of the same genotype and would therefore be susceptible to disease. A few candidates also mentioned that there may not have been a method of chemical control available and that pathogens reproduce and spread very rapidly.

In Part (c) (ii), it was sometimes difficult to separate economic from social consequences such as the rising food prices which can have both social and economic implications. Candidates were generally able to score full marks for this section. A common misconception, however, was that consumption of the diseased plant would cause disease in humans.

### Question 6

This question tested candidates' ability to distinguish between two basic terms used in genetics: an 'allele' and a 'gene', perform a simple monohybrid cross and identify non-genetic causes of variation.

For Part (a), several candidates had difficulty describing a gene as a section of DNA that determines characteristics of an organism, and alleles as different forms of a gene, usually occurring in pairs. This distinction needs to be reinforced by teachers and can be reinforced using appropriate laboratory activities which involve constructing models of chromosomes/DNA using familiar materials such as beads or peas to represent alleles.

In Part (b), many candidates did not appear to understand the meiotic basis for the outcome of the crosses and omitted the parent genotypes and resulting gametes from their genetic diagram. Candidates should be reminded of the convention that the upper and lower case of the same letter should be the symbols used to represent the genotypes in crosses involving complete dominance. For example, if upper case 'P' is used for purple, the dominant allele, then lower case 'p' should be used for white, the recessive allele. Candidates were usually able to show the fertilization cross using a Punnett square to illustrate how the F<sub>1</sub> genotype, ratio and phenotype were derived, but some of them lost marks for not including the genetic ratio of the offspring.

Candidates with limited knowledge of genetics were able to pick up at least one mark from Part (c) by noting that the environment plays a role in the expression of phenotypic characteristics. Most candidates could not get the full three marks since they did not elaborate on how environmental conditions such as food availability, climate or temperature would contribute to differences in phenotype. Many candidates had the misconception that mutations could contribute to differences in phenotype among *genetically identical offspring*.

### **Paper 03/2 – Alternative to the SBA**

This paper assessed the range of practical skills required of biology students and consisted of three compulsory questions. Although there was significant improvement in performance during this sitting of the examination, candidates continue to display weak practical skills, especially in aspects of planning and designing, including the assembling of apparatus, describing methods of experiments and in drawing conclusions from data. These observations reinforce the need for teachers to provide opportunities for students to develop their practical skills. Once again, the examining committee reiterates that candidates *must have been exposed to actual experimenting and investigating scientific phenomena, discussions, explanations and rationalizing of procedures and outcomes* so that they become capable of developing and manipulating experiments and experimental data on their own.

#### Question 1

This question tested a range of candidates' experimental skills as would be required when undertaking an ecological investigation of the range of organisms in their environment.

In Part (a) (i), candidates were required to show the relative size of the animal populations taken from data on a bar graph consisting of the estimated numbers of organisms in a grassy field. Most candidates were able to score almost full marks but some lost marks for failing to include a title and labelling the axes. In Part (a) (ii), candidates were asked to identify one organism that is likely to be preyed upon. Candidates were usually able to state that those organisms that had larger numbers or which were more abundant were more likely to be preyed upon.

Part (b) required candidates to describe how they would have used a quadrat to arrive at the estimated number of plants in the grassy field and then to suggest two other methods that could have been used to collect the data, giving reasons for their suggestions. This part of the question was poorly done by most candidates, suggesting that they had limited experience carrying out ecological investigations using equipment such as quadrats, transects, Tullgren funnels, pit traps or nets for small flying insects.

Part (c) (i) asked candidates to identify features of the organism shown in the figure provided that could be used to classify them. Despite the poor quality of the drawings of the specimen, most candidates were able to gain both marks allocated to this section by stating the number of legs, body segments, wings or antennae which could be used to classify the organism. Part (c) (ii), however, was generally poorly done as candidates lost marks if they ignored the instruction to make a drawing of Specimen C twice the size shown in the figure provided or did not provide a representative drawing of the specimen or shaded their drawing or did not include an appropriate title. Candidates continue to display weak drawing skills and lack knowledge of the conventions of biological drawings, such as the inclusion of magnification and titles of the drawings. In addition, far too many candidates presented untidy drawings with crooked labelling lines.

## Question 2

This question required candidates to present the data provided in a table in a graphical form. Candidates were also required to estimate the height of the plant at days 18 and 31.

For Part (a) (i), several candidates drew line graphs while others attempted a combination of both. A few drew bar charts. Candidates were not penalized for the type of graph drawn but marks were awarded for an appropriate title, appropriate labels and orientation of the axes, accuracy of plots and neatness of the graphs. Many candidates lost marks for neatness and the absence of a title; these criteria need to be emphasized when preparing candidates. Those candidates who gave titles often used that given for the table in the question with little meaningful variation. An appropriate title might have been: *Histogram/Line graph showing the changing height of a Pigeon Pea Plant (cm) measured at weekly intervals over a 7-week period.*

For Part (a) (ii), most candidates were able to estimate the height of the seedling using data from the table while many used the line graph/histogram.

In Part (b), candidates were required to determine plant growth by measuring the dry mass. Few candidates seemed familiar with this procedure and failed to include an oven as one of the required pieces of apparatus. Some included sunlight, dehydrating agents for drying. In describing this procedure, it must be emphasized that several plants have to be used in the process and weighing must be repeated until there is a constant weight being observed. Most candidates said that destruction of the plant is a disadvantage of using this method.

The most popular precaution stated was ensuring that the scale was calibrated to determine the weight accurately. Others could have been to ensure that all soil particles were removed and the plants were dried to constant mass.

In Part (c), most candidates gave nitrogen as the element. Nutrient element was the key to arriving at the correct response since candidates gave incorrect responses such as protein, carbohydrates, nitrates, nitrogenous waste and carbon dioxide. Although Part (d) asked candidates to outline the role of leguminous plants, few of them mentioned the fixation of nitrogen by (Rhizobium) bacteria in the root nodules of legumes. They generally mentioned the role of the pigeon pea in recycling nutrients in the food chain and as producers. A misconception candidates seemed to have was that the end product of nitrogen fixation is nitrates. The end product is in fact ammonia which is then used to synthesize proteins.



### Question 3

This question tested candidates' ability to manipulate, represent and interpret data on the food groups comprising a balanced diet.

Part (a) assessed candidates' ability to calculate data presented in the pie chart as percentages and then to represent the results as a bar graph. Several candidates gained full marks for doing accurate calculations but many lost marks for not including a title or labelling the axes of the graph as required in Part (b).

Part (c) tested candidates' ability to decide on the appropriateness of one graphical method as opposed to another when presenting their results, given the type of data they have. Candidates who thought the pie chart was more appropriate were expected to say that the chart makes it easy to see the relationship between the types of foods and groups and links familiar foods with the groups; while those who thought the bar graph was the better method should have mentioned that this graph shows the differences in the percentage contribution of the different constituents of a balanced diet more clearly or focuses on the different components.

In Part (d), candidates were asked to suggest why staples form the largest part of a balanced human diet. Expected responses were to have included the fact that staples contain large amounts of carbohydrates that provide energy/provide fibre.

**CARIBBEAN EXAMINATION COUNCIL**

**REPORT ON CANDIDATES' WORK IN THE  
SECONDARY EDUCATION CERTIFICATE EXAMINATION**

**MAY/JUNE 2011**

**BIOLOGY  
GENERAL PROFICIENCY EXAMINATION**

**Copyright © 2011 Caribbean Examinations Council  
St. Michael, Barbados  
All rights reserved.**

## **GENERAL COMMENTS**

The June 2011 examination in Biology at the General Proficiency level was the 37th sitting of this subject conducted by CXC. Biology continues to be offered in both January and June. The biology examination is one of the more popular of the single sciences offered at the CSEC level and in 2011 assessed the performance of approximately 16,000 candidates. The examination comprises four papers: Paper 01 – Multiple Choice; Paper 02 – Structured/Extended Essay paper; Paper 03 – School-Based Assessment (SBA); and Paper 032 – Alternative to the SBA (offered only to private candidates).

Overall performance in 2011 was similar to that of 2010 with candidates scoring across the full range of marks in almost every question. However, candidates were challenged by their lack of knowledge of the specifics of biological concepts, their inability to analyse data and account for trends, and most importantly to make drawings that adequately represent biological specimens. Many candidates also had difficulty recalling and spelling the names of biological processes and events. Candidates are still unable to adequately display the skills they are supposed to acquire in pursuing practical work, for example, data representation and methods of investigation. These comments relate to teaching of the subject matter and calls for students having more opportunity to express for themselves the concepts, principles and processes — writing these down and checking for accuracy as well as for engaging in practical activity, including field/laboratory work, and not merely writing up experiments in notebooks. Further, there is insufficient attention paid to several suggestions, which the Biology examiners have repeatedly made over the past years.

## **DETAILED COMMENTS**

### **Paper 01 – Multiple Choice**

Paper 01 consisted of 60 multiple-choice items. Performance on this paper was quite similar to that of 2010. The mean for the paper was 60 per cent compared to 61 per cent in 2010. Most questions had acceptable p and r values. The items on this paper which were most challenging for candidates were those that tested their knowledge of plant biology. These topics included sexual and asexual reproduction in plants, the role of auxins in plant growth with particular reference to the unilateral growth of plant seedlings towards light, as well as the role of various types of plant tissues.

Teachers should stress that seed formation results from sexual reproduction, which involves fertilization. The location of the male and female gametes in flowering plants should be made clear. The distinction between fertilization and pollination as well as between self and cross-pollination should also be clarified.

The role of auxin and the way it is distributed in the stem should be outlined in explaining why stems of plants grow towards the light.

Greater attention should be paid to the structure and function of various plant cells and tissues, for example, cambium, parenchyma, meristems, epidermal cells.

## Paper 02 – Structured and Extended Essays

Paper 02 consisted of six questions, three of which were in the structured response format and three in the extended essay format. This paper tested all profile skill areas identified in the Biology syllabus. All questions were compulsory. Candidate performance on this paper was slightly better than performance on the June 2010 paper. Candidates were able to gain marks across the range for almost all questions and the mean for most questions was relatively close to the mid-point of the range.

Since candidates were able to generally attain marks across the allotted range for the questions, with the exception of Question 5. It is evident that most of the marks on the paper were available and attainable.

### Question 1

This question tested candidates' data analysis skills and their knowledge of transport in plants. The mean mark scored was 12 and the median was 11.

Part (a) (i) required candidates to illustrate, by means of a graph, data for transpiration rates of celery stalks at different temperatures. This was generally well done, with a fair number of candidates scoring full marks. Commendably, data points were accurately plotted, scales for the axes were recorded and the dependent variable was represented on the y-axis. Candidates need to be reminded of the need to choose axes scales that allow maximum use of the graph page, quote units in the labels for the axes and include a self-explanatory title. A self-explanatory title mentions the subject of the experiment, the manipulated variable and the observations made. An example of such a title is *Distance moved by dye up celery stalks at varying temperatures*. It should be emphasized to candidates that the title format *name of independent variable vs. name of dependent variable*, for instance, *time vs. distance* is not acceptable in Biology, although it may be used in the other areas of science.

Part (a) (ii) required candidates to account for the observed trends in the data. Candidates who did not score full marks here seemed to misinterpret the word 'account'. A biological reason for the observations should have been offered and not a description of the data. Candidates' attention should be drawn to the Glossary of Terms used in Science Papers, located at the end of the current CSEC syllabus.

Part (b) tested candidates' ability to formulate a suitable aim for an experiment, given the experimental procedure. Although candidates seemed knowledgeable of the content of the Aim statement, a large number of them were unable to offer a well-written one. An acceptable Aim includes a verb, the manipulated variable, observations to be made and the subject of the experiment. An example of such an Aim is *To investigate the transpiration rates of celery stalks at different temperatures* or *To determine the effect of heat on the transpiration rates of celery stalks*.

In Part (c), identification of Flask A as the control seemed easy for most candidates. A pleasing number of them appeared to know that a control is an arrangement of apparatus, identical to the experimental arrangement, except the manipulated variable.

A conclusion, drawn from the data, was required in Part (d). A well-written conclusion is a one-sentence response to the Aim, often describing the effect of the manipulated variable on the results. An example of a well-written conclusion is *Temperature increases the rate of transpiration in celery stalks*. A number of candidates included reasoning and explanation in the conclusion statement.

Part (e) asked for a description of the physical processes involved in the movement of water through specified routes. A number of candidates were able to score full marks. Responses which were not awarded full marks often had incomplete descriptions of the processes, often merely identifying them. This underscores the need for candidates' familiarity with the Glossary of Terms used in Science Papers. The word 'describe' should have guided candidates to name the process and state how it is done. As an example, an appropriate description of 'capillarity' is *adhesion of water molecules to the sides of xylem vessels and cohesion of these molecules to water molecules in the centre of the vessels results in the rise of water up the xylem tissue.*

No marks were awarded for descriptions involving routes which were not mentioned in the question. A common misconception is that water is drawn up the xylem vessels solely by capillarity. While this contributes to the upward water movement, it cannot account for the long distances over which water is transported. The negative pressure at the upper areas of the xylem, generated by transpiration, results in an upward suction effect in the xylem and so allows upward water movement over large distances. Another common error found was the synonymous use of the terms 'transpiration stream' and 'transpiration pull.' A third area of concern is the number of responses citing root pressure as the only force responsible for upward water movement in the xylem. Root pressure may be high in the lower areas of the xylem but is not high enough to send water to the leaves. Thus, it may cause guttation but is insufficient to cause transpiration. It was also commonly thought that osmosis is responsible for the upward movement of water up the xylem.

Part (f) was well answered, with correct responses including the small diameter of xylem vessels to facilitate capillarity, degeneration of end-walls to allow formation of a continuous tube, lignification of vessels to withstand the negative pressures of the transpiration pull and degeneration of cytoplasm to allow uninterrupted water flow. An extremely common misconception was the idea that lignification is necessary to withstand the high pressures generated in the xylem. Too many candidates seemed unaware that the pressure in the upper xylem is so low that it becomes negative, that is, a 'pull' instead of a 'push'.

The benefits of transpiration, required in Part (g), provided relatively easy marks for a number of candidates. Marks were awarded for benefits such as the provision of water for photosynthesis and other metabolic reactions, the maintenance of turgidity, loss of heat by the evaporation of water and the uptake of dissolved minerals from the soil. A number of responses described transpiration as a means of removal of excess water, which would otherwise cause lysis of cells and 'drowning' of plants. This highlights inadequate knowledge of concepts as fundamental as the role of cell walls in plants.

The identification of phloem tissue as the means of transport of the products of photosynthesis in the form of sucrose, in Part (h), was well done. More than half of the responses had, however, incorrect spellings of the word *phloem*. A large number of candidates seemed unaware that the glucose produced in photosynthesis is converted to sucrose in order to be transported in the phloem. Too many of them stated that glucose is transported in the phloem. A number of them cited starch as the material transported, despite the insolubility of starch.

Part (i) required candidates to compare the transport systems of flowering plants and the transport system of mammals. Most responses were unable to score full marks in this part. Acceptable differences include the presence of a pump and valves in the mammalian system but not the plant's transport system. Similarities include the use of water as a solvent and the network of vessels found throughout the organisms.

## Question 2

This question tested candidates' knowledge and understanding of the processes of aerobic and anaerobic respiration. Candidates were able to score across the full range of marks with the average mark being six.

Part (a) (i) was fairly well done. Candidates were expected to suggest one reason why humans need oxygen to stay alive. The role of oxygen in the oxidation of glucose to release energy during aerobic respiration or any variation of expression was the expected answer. Many candidates were able to give a reasonable suggestion.

In Part (a) (ii), candidates were expected to write the following chemical equation which summarizes the process for which oxygen is required in living cells:



Many candidates were unable to write this chemical equation. Those candidates who did not balance the equation gained one of the two possible marks. Part (a) (iii) required candidates to name aerobic respiration as the process occurring in the previous section. Most of them simply wrote 'respiration'. This indicates that there is a need for a distinction to be made between the cellular processes of aerobic and anaerobic respiration.

Part (b) (i) was poorly done. Few candidates were able to explain why Usain Bolt's muscles became starved of oxygen during his spectacular sprint in the Olympic games. Acceptable answers included:

- His breathing could not keep pace with respiration taking place in his muscles.
- Exercising muscles need more oxygen than normal.
- Time taken for enough oxygen from lungs to be delivered to cells.
- His heart cannot pump blood fast enough.

Most candidates were able to identify lactic acid as the substance produced in Bolt's muscles, which were starved of oxygen.

Part (b) (iii) was fairly well done. Candidates were expected to explain how lactic acid could affect Bolt's performance if he continued running for another 10 minutes. Accepted explanations included the fact that Bolt's muscle would ache, cramp or become fatigued. As a result, Bolt would slow down or suffer a decrease in performance. Most candidates scored at least one mark.

Few candidates were able to score the mark for Part (c) (i) which required them to name anaerobic respiration as the process by which plants obtain energy in the absence of oxygen. Too many candidates indicated photosynthesis, which suggests that there remains the misconception that "plants photosynthesize during the day and respire only at night".

Another possible conclusion is that some candidates ignored (or did not read/understand) the first sentence and zeroed in on the key words 'plants' and 'energy', and hence answered '*photosynthesis*' instead of *anaerobic respiration* (incomplete oxidation of glucose in the absence of oxygen to produce ethanol, carbon dioxide and some energy). Very few candidates were able to describe anaerobic respiration, although they were generally able to identify products of anaerobic respiration such as lactic acid and ethanol.

Some common misconceptions were:

- Alveoli or lungs described as the organelle for the site of respiration
- Yeast is a product of anaerobic respiration

### Question 3

This question tested candidates' comprehension of basic aspects of energy transfer in a food chain and the nitrogen cycle. Candidates' scores ranged between 0 and 15 marks, with a modal score of 7 and a mean score of 7. A few candidates did not provide a response to the question.

Part (a) required candidates to explain the unique role of the producers in the ecosystem. This part of the question was well done. Candidates were able to indicate that the role of producers in an ecosystem is to ensure that energy entered the ecosystem for the survival of the organisms further along the food chain.

Part (b) gave stimulus information in the form of a concept map showing transfer of energy from the sun through producers and consumers in a food chain. This section was well done. Most candidates were able to distinguish primary consumers and secondary consumers clearly. However, some candidates used the term omnivore to describe organism B. This term could be applied to organisms at A as well. Based on the given concept map, omnivore was not accepted.

In Part (b) (ii), an explanation of the role of B in the ecosystem was required. Most candidates were able to suggest a named carnivore and describe its role in the ecosystem. Other responses which included a named organism that exhibits omnivore-feeding patterns such as 'bird, human, fish, etc' were accepted. Some candidates' responses included named herbivores. These were not awarded marks.

Part (b) (iii) asked candidates to give one example of a decomposer and explain how a decomposer releases carbon to the atmosphere. The correct response to this question was fungi, bacteria, saprophytes or actinomycetes. Many candidates named detritivores or scavengers instead of decomposers. This indicates that the role of the various types of organisms which feed on dead and waste matter needs to be clarified.

In Part (b) (iv), the concept of the food cycle and the food chain were examined. This section presented the greatest challenge for candidates which indicates that the concept of the one-way flow of energy through the ecosystem is not well understood. Most candidates did not score a mark in this section. The suggested answers were:

- As energy flows through the trophic levels energy is lost as heat to the environment while materials transported to each organism can be recycled.
- Some energy is used up at each trophic level while materials (water, carbon, nitrogen etc.) can be reused/ recycled.
- The sun's energy is infinite while materials are finite and therefore must be recycled.
- There is no known mechanism for returning the energy to the sun while organisms aid in the recycling of materials.

Part (c) asked candidates to draw a diagram of the nitrogen cycle showing the links between four named processes. Many candidates knew the names of four processes in the nitrogen cycle, but could not correctly identify them in the cycle. Most candidates were able to name an organism responsible for one of the processes in the nitrogen cycle, for example, Rhizobium, Azobacter, leguminous plants.

#### Question 4

This question was designed to test candidates' theoretical as well as practical knowledge of the structure/function relationship of a leaf for the process of photosynthesis. It was fairly well answered and was able to discriminate those who had a good grasp of this process and those who did not.

For Part (a), most candidates were able to state two ways in which the leaf is adapted for photosynthesis. These include *flat, thin surface to capture light; held at an angle to capture sunlight; presence of chloroplast in palisade layer; chlorophyll to trap the solar energy; network of veins (xylem vessels) to supply water needed in photosynthesis and phloem cells to transport manufactured food; presence of stomata for entry of carbon dioxide.*

In Part (b) (i), most candidates were able to score the allocated four marks. Some candidates lost marks for not putting a title and others for inaccurate labels. The use of a key and stippling is to be discouraged for a diagram of this nature. Simple lines and labels would suffice to represent a variegated leaf.

For Part (b) (ii), very few candidates chose the non-green areas as the part of the leaf that would change colour. There appeared to be some confusion with the colour change due to the 'destarching' with alcohol and the formation of the starch-iodide complex. In Part (b) (iii), while most candidates stated 'blue-black' as the colour change, many of them did not indicate the original colour of the iodine. There were many candidates who indicated that the leaf changed colour rather than the iodine, which reacted with starch molecules to produce the blue-black iodide-starch complex. Some candidates stated that the colour change was purple.

For Part (c), most candidates were able to state the role of chlorophyll in photosynthesis. They were also able to explain the formation of starch (from carbon dioxide and water) with glucose as the intermediate. However, candidates were less able to clearly relate this theory to the practical investigation using the variegated leaf, which demonstrated the need for chlorophyll in photosynthesis.

In Part (d), most candidates knew that 'food' manufactured in leaves was transported in the phloem to other parts of the plant for storage. If they indicated the material was used for respiration/growth processes, they were not penalized. Several candidates thought the material transported was either glucose or starch. Some candidates interpreted *parts of the plant that do not contain chlorophyll* as the non-green areas in the leaf.

#### Question 5

This question was poorly done as illustrated by the mode of 0 and mean of 3. Although most candidates were able to score the two marks allocated to Part (a), many of them were too general in stating urine or nitrogenous waste instead of specifying the components of urine.



The answers to Part (b) indicated that candidates had many misconceptions with regard to the formation of urine. Some of them apparently confused the process of egestion with excretion, for example, 'after digestion excess or unwanted substances go from the intestines to the kidney for excretion'. Candidates did not seem to understand clearly how urine is formed from blood by the processes of ultra-filtration, re-absorption and secretion. Too many of them referred to blood passing through the kidney tubule (nephron) rather than the filtrate. Many candidates did not do an annotated diagram. Candidates should be reminded to pay attention to the meaning of this term. The glossary in Appendix 5 of the syllabus indicates that the term *annotate* means to *add a brief note to a label; simple phrase or a few words only*.

Part (c) asked candidates to account for the presence of blood cells and glucose in the urine. Most candidates were able to score two out of the four available marks for mention of malfunction, disease, damage, hypertension and diabetes. Far too many candidates referred to hypertension as 'suffering from pressure' and diabetes as 'having sugar'. Attention should therefore be paid to the use of accurate terminology for commonly known conditions.

### Question 6

This question was attempted by the majority of candidates. The overall performance of candidates was average. The marks obtained by candidates showed a normal distribution with a mean mark of 7 and a mode of 6.

Part (a) (i) tested candidates' knowledge of the four categories of disease: pathogenic, nutritional deficiency, hereditary and physiological. This part was generally well done with candidates being able to score most of the four marks for identifying a named example of each of the categories of diseases. Candidates knew the names of many diseases and gave a wide range of correct responses. Some candidates used common names of diseases such as 'sugar', iron deficiency and deformation of bones rather than the biological, which were not accepted. Other candidates gave names of psychological diseases for physiological diseases indicating a misunderstanding of the two terms.

Part (a) (ii) required candidates to compare the methods of treating and controlling the pathogenic and physiological diseases named in (a) (i). Most candidates scored a maximum of three marks for identifying the differences but lost one mark since they did not identify the similarity. Some accepted responses for differences include: lifestyle choices; education; medication/drugs; vaccination; surgery; hygiene for pathogenic disease; diet and exercise for physiological disease. Candidates focused on the prevention of the diseases. In addition, they did not use appropriate linking words to compare, rather they wrote the response for each separately. Some candidates gave general answers comparing the categories of disease without specifying the two diseases, which they named in Part (a) of the question.

For Part (b) (i), candidates were required to state the meaning of *genetic engineering*. Most candidates only scored one out of the two available marks since it was evident that they did not clearly understand the definition. They confused genetic engineering with cloning, grafting, artificial selection and crossing-over. Acceptable responses included the idea of inserting genes from one organism into another so that the genotype of the genetically engineered organism is altered.

Candidates were able to score marks in Part (b) (ii) for discussing the social, ethical and ecological implications of genetic engineering. While many candidates discussed each, most of them were not clear about the meaning of the terms social, ethical, ecological and implication. As such, they spoke of ethnicity rather than ethical; and they discussed socialization of plants.

### Paper 032 – Alternative to SBA

This paper assessed most of the practical skills required of biology students. Candidates continue to display weak practical skills especially in aspects of Planning and Designing, including the assembling of apparatus, describing methods of experiments and in drawing conclusions from data. These observations indicate that candidates should be exposed to actual experimenting and investigating scientific phenomena, discussions, explanations and rationalizing of procedures and outcomes so that they can develop experimental skills.

Candidates continue to display weak drawing skills and lack of knowledge of the conventions of biological drawings, such as the inclusion of magnification and titles of the drawings. In addition, far too many candidates presented untidy drawings with crooked labelling lines.

#### Question 1

This question tested candidates' drawing skills, their knowledge of the parts of a fruit and their understanding of food tests. The responses were generally poor.

The performance in Part (a) was the better of the two sections. Most candidates were able to gain at least four of the 11 marks available in this section. Many candidates failed to provide a title to the drawing and the accuracy of the representation of the cut orange was often very poor. Candidates also lost marks for lack of clarity due to shading and the absence of clean, clear, smooth lines. Several candidates had difficulty depicting a transverse section and instead gave a 3-D representation. In Part (a) (ii), the majority of candidates were unable to either correctly calculate the magnification or write the correct notation with the times (x) in front of the calculated value.

Part (b) was poorly done. In (b) (i), though most candidates were familiar with the test reagent, iodine and the colour change from brown to blue-black associated with starch, they appeared less knowledgeable about the protein test which used  $\text{KOH} + \text{CuSO}_4$  (Biuret test) with a colour change from blue to purple, and reducing sugar test which used Benedict's with a colour change from blue to red-brown. Candidates must be reminded of the importance of reading questions carefully. Many of them gave the colour of the food substance before the test and not the colour of the reagent as required.

Many candidates misinterpreted what was required for Part (b) (ii), often giving properties of the pulp, rind and seed cotyledon. Few candidates were able to relate the presence of the food substance to its role in dispersal or to the survival of the plant itself. Acceptable answers included:

- Pulp – to attract agents of dispersal/as a food source
- Rind – gives a scent to attract agents of dispersal/prevent evaporation
- Cotyledon – food for germinating seed

#### Question 2

This question posed great difficulty for candidates. In Part (a) (i), many of them failed to correctly read the volumes in the measuring cylinder, often reading the top of the meniscus recording values of  $72 \text{ cm}^3$  instead of  $71 \text{ cm}^3$ , and  $62 \text{ cm}^3$  instead of  $61 \text{ cm}^3$ . Candidates were often unable to correctly state the aim required in Part (a) (ii), although many of them were able to use the indicative terms *to find out/to investigate*. Expected answers included:

- To find out/investigate/compare the water-holding capacity of two types of soil: soil X and Y.

In Part (a) (iii), many candidates were unable to differentiate between a precaution and good basic experimental technique. Acceptable responses included:

- Soil sample should be dried thoroughly to avoid different water content at the start of the experiment.
- No errors in reading measurement: to avoid inaccurate readings — read at eye level, use a flat surface, read the bottom of the meniscus.

In Part (a) (iv), the answers provided were often vague, lacking in the scientific terminology/jargon required at this level. Words like ‘soaked up, absorbed’ were loosely used and most were unable to make the connection between the change in volume and airspaces. Answers were expected to relate the change in volume seen in each cylinder to the properties of Soil X and Y. Candidates should also be encouraged to use the number of marks awarded to get an idea of the depth of the answer required.

Cylinder A:

*Soil X particles smaller than Soil Y*

*Less air spaces in soil X*

*Soil X is clay*

Cylinder B:

*Soil X particles larger than Soil X*

*More air spaces in Soil Y*

*Soil Y is sandy soil*

Parts (b) (i) and (ii) were the best answered in this question, with candidates scoring at least two out of three marks.

Question 3

Performance on this question was fair. In Part (a) (i), most candidates were able to plot values. However many of them did not include a title, and/or the axes with units. Candidates often used scales that were too small. As a result, they utilized less than half the graph paper provided. Candidates often confused the position of the two axes, placing the dependent where the independent variable should be and vice versa. However, several candidates were unable to correctly place incremental numerical values on the x and y-axes.

Many candidates were unfamiliar with the way in which a hypothesis statement should be made often providing an aim statement instead. They were also often unable to differentiate between a precaution and a limitation. Acceptable answers included:

Hypothesis

*The closer the light gets to the eye, the smaller the pupil.*

Limitations

*Eyes could get tired.*

*Fluctuations in electricity.*

*Eye defects.*

In Part (b), many candidates did not recognize that there are two muscles in the iris — the radial and circular muscles that control the size of the pupil. In addition, many candidates who attempted this question explained accommodation instead of the antagonistic movement of the muscles in controlling the size of the pupil. Acceptable answers included:

- Contraction of circular muscles decreases the diameter of the pupil, while contraction of the radial muscles increases the size of the pupil.

Most candidates were able to pick up at least one mark for concave or diverging lens, or laser surgery.

### **Paper 03 – School Based Assessment**

Performance on the School-Based Assessment was commendable at some centres. Favourable trends that continue to be observed include: good syllabus coverage (that is, a minimum of nine syllabus topics covered) by most of the centres that were moderated; an increase in the number of centres where both quantitative and qualitative fieldwork were done and the number of times practical skills were assessed generally complied with syllabus guidelines. This suggests that most teachers recognize the value of providing sufficient opportunity for students to develop and master all the specific practical skills. However, while the skill of Observation, Recording and Reporting (ORR) was generally well done, Drawing (Dr), Analysis and Interpretation (AI) and Planning and Design (PD) continue to present candidates with the most difficulty.

While the level of organization and presentation of books submitted from most centres was good, there were still some centres that submitted books without the requisite information. The CXC Biology syllabus (page 44) provides guidelines for students' preparation of practical books for submission. Some important requirements often not met include: presence of a Table of Contents providing a list of the aims of practical activities, page numbers, dates, as well as clear and specific indication of the activities used for the SBA together with the skills being assessed for each activity. In addition, the marks awarded for each practical activity must be placed alongside the activity and not simply listed at the front or back of the books.

The lack of comments in the books, especially for skills performed poorly suggests that students are not being given adequate feedback on their progress throughout the period of study. Frequently, only ticks are observed, along with the final score awarded for the skills but students appear unaware of their strengths or deficiencies.

The moderation exercise was often hampered by poor mark schemes. Teachers are reminded that mark schemes must be legible and preferably bound together instead of on loose sheets of paper. There must be a clear and direct relationship between the marks awarded to the appropriate activities in the practical books and to the marks on the tally sheets. It should also be noted that no more than two skills should be assessed in a single practical activity. New teachers in particular should consult pages 38–44 of the Biology syllabus for guidance in preparing and presenting mark schemes.

The following is a list of criteria which teachers should follow in marking SBA activities.

- Marks should be awarded for each skill separately. It is noted that in some cases, marks were given for the each skill then tallied to give a composite score. This is unacceptable.
- Marks awarded to students' work should be a fair indication of its quality. Too many candidates received high marks for work that fell short of the CXC standard. This was particularly noticeable for Planning and Design, Analysis and Interpretation and Drawing. When the CXC standard is not observed there is great disparity between the teacher's score and that of the moderator. This circumstance is usually disadvantageous to the students.

- Marks submitted on the moderation sheet should reflect the students' marks in each of the samples. Consistency of marking and submission of marks relate to the reliability of the process and thus acceptability of marks submitted.
- Teachers are once again reminded that body fluids such as saliva, blood and urine are not to be used for practical work. These can be sources of infection and may have serious legal implications should a student become infected while conducting practical work. Plant materials must be removed from books before they are submitted to CXC, since these are also potential agents of infection when moved from place to place.

The examining committee would also like to recommend that there be greater cooperation among teachers of similar subjects at the same centre and mentoring of new teachers, to ensure that standards are consistently maintained.

A review of previous subject reports will provide additional suggestions for developing practical skills. Further suggestions are reiterated in this report and each teacher is alerted to the specific strengths and weaknesses displayed by their candidates in the Moderation Feedback Report sent to schools from CXC, after moderation. The Moderation Feedback Report, which is sent to each centre, provides constructive and useful information relevant to the particular teacher(s). This report offers specific recommendations and is intended to assist teachers in the planning, conducting and assessing of practical work — in the laboratory and field. Improvement of students' practical skills will have a direct influence on their overall performance in the Biology examination, since certain questions, notably Question 1 on Paper 02, and questions on Paper 032 are based on knowledge and application of these practical skills.

### **SPECIFIC COMMENTS ON THE ASSESSMENT OF SKILLS**

The following information is to assist especially new teachers of Biology in interpreting the information given on the CXC Moderation Feedback Report. *It should first be noted, however, that the number of times a skill is assessed is considered sufficient if assessed a minimum of four times, except for the Planning and Design skill which is assessed twice* (see page 37 of the Biology syllabus).

#### **Observation, Recording, Reporting (ORR)**

These skills appear to have been mastered at most centres. For most of the work observed, the method was clearly described with logical sequence of activities. It was also observed that generally, the past tense was correctly used in the presentation of the report on the practical activity as required. Candidates should be encouraged to give careful attention to grammar, quality of expression and giving as much details as possible when reporting their procedures and observations, as science students need to appreciate the importance of clarity in explaining their results. Where possible, students should also be encouraged to repeat procedures and give average results to improve the reliability of their results.

The tables and graphs were usually clear and provided adequate details, which allowed for clear description and discussion of the experiment. The examining committee recommends that teachers give more activities where students construct their own tables and graphs using their results. This will allow them the opportunity to develop these skills.

When using tables, teachers should remind candidates that the title should be written in capital letters, and appropriate column headings should be given. See example below.

**Example:**

TABLE 1: FROG POPULATION OBSERVED FROM OCTOBER 1997 TO OCTOBER 2004

Year	Number of frogs
2004	5
2001	110
1997	125

When presenting graphs the title should be *written below the graph and underlined*; axes should be *labelled* with *units* stated and a *key* should be given if necessary.

If calculations are required, all necessary calculations should be presented neatly and in an organized fashion. Units should also be included where necessary.

Where drawings are used in reporting observations, they should meet standard SBA drawing criteria.

### **Drawing (Dr)**

There has been a general improvement in the clarity of drawings done by students at most centres. Some teachers continue to reward high marks to drawings that do not meet the CSEC standard. The examining committee does not expect drawings to be works of art, but they should meet the criteria for accuracy, clarity, labelling and magnification. Teachers should ensure that students are given several opportunities to practise and develop drawing skills.

It is a requirement that drawings must be practised from actual specimens and not from textbooks. Specimens must include drawings of *flowers, fruits, storage organs and bones*. Additional examples may be included in practical books. However, *microscope drawings, models and apparatus should not be used for SBA assessment*. Drawings of cells while useful for teaching should not be assessed at this level. Similarly, dissections may help students to understand structures such as the digestive system but they are too complex to be drawn accurately at this level. These difficult drawings do not provide a fair test of ability at the CSEC level.

Accuracy and labelling continue to be problem skills and there appears to be some degree of inconsistency — even among teachers at the same school — in how they are assessed. Label lines should be drawn with a ruler and as far as possible, labels should be written in script so that they can be easily read. Annotations that accompany drawings should be as brief as possible and clearly and neatly written.

Table 1 is a list of DOs and DON'Ts applicable to SBA biological drawings at the CSEC level.

**TABLE 1. DOs AND DON'Ts OF BIOLOGICAL DRAWINGS**

DOs	DON'Ts
<ul style="list-style-type: none"> <li>• Use pencils for all drawing activities – drawing, label lines, labels</li> <li>• Use drawings of actual biological specimen (not diagrams, models or textbook drawings); ensure for assessment there are drawings of flowers, fruit, seeds and bones</li> <li>• Let the size of drawings be at least half page</li> <li>• As far as possible, have label lines and labels positioned at right side of drawing</li> <li>• Let all label lines end at the same vertical plane</li> <li>• Let label lines be drawn parallel to the page top/bottom</li> <li>• Ensure label lines end on part being made</li> <li>• In the title, use the word 'drawing' and not 'diagram'</li> <li>• Position title under the drawing and indicate the actual name of the specimen (for example, cervical vertebrae of a goat, mango leaf, hibiscus flower) <b>and</b> the view drawn</li> <li>• Underline the title</li> <li>• Include the magnification and state where appropriate, actual length and width of specimen as well as place 'x' in front of the magnification</li> <li>• Write magnification to one decimal place</li> <li>• Use a key to explain symbols where appropriate, for example, stippling/cross hatching</li> </ul>	<ul style="list-style-type: none"> <li>• Do not use arrow heads</li> <li>• Do not cross label lines</li> <li>• Do not use dots or dashes</li> <li>• Do not join letters of words for label or title</li> </ul>

The examining committee also encourages teachers to ensure that standard drawing criteria are applied whenever drawings are required in laboratory activities, especially when reporting observations and/or illustrating biological processes, for example, germination, regardless of whether DR skills are to be assessed or not. This should help students appreciate the importance of the skill.

Teachers should also ensure that students draw on plain paper and then neatly insert drawings into lab books, if the books are not designed with plain sheets of paper for drawing. Distinguishing features and labelling lines are oftentimes unclear when drawings are done on ruled sheets of paper.

## **Analysis and Interpretation (AI)**

This skill continues to present problems for the majority of candidates. Many teachers continue to use questions to stimulate discussion. This device is good for helping students to develop their AI skills. However, they should not be used excessively, nor should they be the only means of assessment. These questions must guide students to provide the required background information, give explanations for the results, draw conclusions and show an awareness of possible limitations. The information provided in this way should then be written up as a paragraph of continuous prose as is normally done for the discussion/conclusion. In many cases, candidates seem to have learnt a formula for writing up the discussion but showed no real understanding of how to interpret their own results. As a learning strategy teachers may ask their students to orally explain the results to obtain a clearer view of their understanding and to help them develop their analytical skills.

The marking criteria used by some teachers did not include 'limitations' as one of the criteria. It was sometimes observed that precautions/control/sources of error were often accepted as limitations by the teacher.

The use of controls should also be emphasized in discussions as they are a point of comparison for the experimental set up in which a particular variable has been omitted. This comparison should be included in the discussion as it is the key to drawing the conclusion. Conclusions should relate directly to the aim of the investigation. Students should also be reminded to discuss at least one limitation of the investigation. It is important for them to recognize that the conditions present in a school laboratory are rarely ideal.

The processes involved in demonstrating the AI skill are reiterated here:

- Background information may be written in the 'Discussion', or in the introduction section
- Background information for the experiment must be related to the theory
- Discussion should be an analysis or interpretation of the recorded experimental results. Discussion must not simply answer posed questions for AI:
  - Questions may be used to guide students but answers must be written in paragraph format (without the questions, or written comprehension style)
  - Questions should not to be included in the lab report
- Conclusion must be based on the aim. (It is a brief answer to the aim.)
- Limitation(s) should be included among the AI marking criteria as this is very important to laboratory exercises.
- Identifying source(s) of error and precaution(s) are necessary as is knowing that these are both different from each other and from limitation(s).
- All components of AI (background knowledge, explanation of results, limitations and conclusion) should be included in the mark scheme for the skill.



The examining committee is again reminding teachers that food tests on their own are not appropriate for assessing AI. Simple investigations can be designed in which food tests are used. For example, students can be given unknown mixtures and asked to find out which food would be most suitable for an infant. Food tests can be used also to determine the presence of a particular food before and after digestion by an enzyme. These types of exercises will allow students to develop the necessary skills. Knowledge of the food tests and the nutritional requirements can then provide the background information on which they will base their conclusions.

### **Manipulation and Measurement (MM)**

As has been the trend in previous years, this skill continues to be the one that most candidates appear to have achieved mastery of, based on the observation that most of them are awarded full marks. However, evidence such as the generally poor performance on the practical aspects of Question 1 in Paper 02 of the final examination suggests that the SBA marks for the MM skill may not be the result of rigorous marking. Also, if virtually all students in a class gain full marks on an activity, this suggests that the task may not be demanding enough or the criteria not detailed enough to allow the necessary discrimination between different levels of performance.

The examining committee recommends that teachers expose students to as wide a range of apparatus and their use in collecting data as is possible. This would help to ensure students' manipulation skills develop and allow for a more fair assessment of students' competence in MM.

### **Planning and Design (PD)**

Performance on this skill has shown some improvement relative to former years, and teachers should be commended for demonstrating more creativity in the types of observations/problem statements provided to students on which to base their hypotheses and design their experiments. The examining committee continues to emphasize the importance of using examples from students' local environment as this will help students better appreciate how they can apply their biological knowledge and practical skills to solve problems they frequently encounter. Teachers are reminded that it is inappropriate to have students copy procedures from textbooks and reproduce them verbatim for assessing students' PD skill.

The experiments designed by students from some of the centres moderated indicated that there was some understanding of the procedures involved in planning and conducting an experiment but in some instances, there were no replicates in the investigations. There are still a few areas of difficulty where students were unable to state their hypotheses clearly and relate the aim to the hypothesis. A hypothesis is a testable explanation based on particular observations, about how things work or why something happens.

It is also important that development of the skill start with the commencement of the teaching of the syllabus. In many cases, it was obvious that practical activities targeting the development of the PD skill was among the last set of activities in which candidates engaged prior to the examinations. Figure 1 is an example of how a planning and designing activity might be effectively developed. Students should be encouraged to ask 'why', in other words, to think of an explanation for their observation rather than simply describing the observations.

An example of description of an observation stated as a hypothesis is as follows:

**OBSERVATION GIVEN:** *Someone observed that when bananas are wrapped in paper and placed in a dark cupboard, they ripen faster than those left in the light.*

**STUDENT'S HYPOTHESIS:** *Bananas wrapped in paper and placed in a cupboard ripen faster than those left in the light.*

**SUGGESTED HYPOTHESIS:** *Exposure to light slows the ripening process in bananas.*

The PD activity shown in Figure 1 generated different experimental designs from students at a particular centre, which underscores the point that if students are given clear instructions and guidance, they can become proficient in this skill.

**Example:**

This Planning and Design activity submitted by a centre was based on the following observation:

*Whilst digging his garden, a gardener noticed that there were a lot of earthworms in one area but few in another.*

The teacher's instructions to the students were:

Suggest one possible hypothesis for the gardener's observation. Design an experiment which you could carry out to test your hypothesis. Your design must include:

- Your hypothesis, which clearly relates to the observation given.
- Your aim which clearly relates to your hypothesis.
- A list of the apparatus and materials you would use.
- A clear method, written in instruction format, stating the steps you would use and including a suitable control.
- At the end of your method, clearly identify the manipulated variable, the responding variable and the controlled variable.
- A summary of the expected results – if your hypothesis is correct and – if your hypothesis is not correct.
- An explanation of the limitations of your method.

**Figure 1. Example of a Good Planning and Design Activity**

Two hypotheses related to the example in Figure 1 are:

- Earthworms live only in shaded areas.
- Earthworms are found only in moist habitats.

Relevant aims to the proposed hypotheses include:

- To investigate the distribution of earthworms in well-lit and shaded areas
- To investigate the distribution of earthworms in moist and dry areas

**CARIBBEAN EXAMINATIONS COUNCIL**

**REPORT ON CANDIDATES' WORK IN THE  
SECONDARY EDUCATION CERTIFICATE EXAMINATION**

**JANUARY 2012**

**BIOLOGY  
GENERAL PROFICIENCY EXAMINATION**

**Copyright © 2012 Caribbean Examinations Council  
St Michael, Barbados  
All rights reserved.**

## GENERAL COMMENTS

The January 2012 sitting of the CXC Biology examination consisted of three papers: Paper 01 — Multiple Choice; Paper 02 — Structured/Extended Essay and Paper 032 — Alternative to School-Based Assessment.

The overall performance of candidates in 2012 declined when compared with 2011. Improvements were seen in the performance on Question 1 of Paper 02, which focused on data analysis. This was especially encouraging as candidates in the January sitting have consistently demonstrated poor practical skills suggesting that they have limited practical laboratory experience.

The poor spelling of important biological terms continues to be problematic and sometimes prevents otherwise good candidates from being rewarded with marks.

The examining committee once again reminds candidates to pay careful attention to the stimulus material in each question which is meant to guide them in providing the correct responses. Candidates are also encouraged to make use of the subject reports posted on the CXC website which have similar recommendations about how to approach the answering of Biology examination questions.

## DETAILED COMMENTS

### Paper 01 – Multiple Choice

Paper 01 consisted of 60 multiple-choice items. Performance on this paper was quite similar to that of 2011. Some of the topics that were most problematic for candidates were:

- Diffusion and osmosis
- Significance of boiling the leaf and putting it in ethanol when testing a green leaf for starch
- Transport of minerals in plants
- Emulsion test for fats
- Excretion in plants
- Role of the thyroid gland and thyroxine
- Adaptations of the skin for temperature regulation
- Function of the placenta to include the secretion of hormones during pregnancy
- Role of white blood cells in immunity
- Insect vector-borne diseases controlled by sterilization and the use of disinfectants
- Hot water from power stations as water pollutant

## Paper 02 – Structured and Extended Essay

Paper 02 consisted of six compulsory questions; three of which were in the structured response format and three in the extended essay format. Most candidates were able to score marks across the range for almost all questions.

### Question 1

This question dealt with an investigation of the effect of different concentrations of sugar solution on potato tissue. It tested all three profile skill areas identified in the Biology syllabus, namely Knowledge and Comprehension, Use of Knowledge and Experimental skills. The mean for this question was 11 and the mode was 9, out of a maximum of 25 marks.

Part (a) required candidates to list appropriate apparatus and materials, and describe a suitable method for carrying out an investigation that would allow them to get the results plotted on the graph. Candidates were able to list at least five appropriate apparatus and materials such as a *knife, potato strips, petri dishes, measuring cylinders, balance or scale, pure water, cane sugar solutions of required concentrations, timer* and *blotting paper*. In describing the method, very few candidates included important steps such as *weighing the strips before immersion, blotting the strips after immersion and before weighing them, or calculating the average weight of the strips in each solution and the water*.

Candidates were required in Part (b) to construct a table that was appropriate for recording the data represented on the graph. While candidates seemed aware of the general format of tables, very few scored full marks. Generally, it is expected that candidates at this level should produce tables containing appropriate titles, headings and units of measure. Tables should also be well ordered (neat) and closed.

Part (c) (i) asked candidates to explain the results when the strips were placed in pure water. Candidates were able to get full marks if they said that *the weight of the strips increased because water moved from a region of high concentration in the petri dish to a region of low concentration in the potato cells*. In Part (c) (ii), candidates were required to explain the results below and above 1.0 M sugar solution. Candidates were awarded marks for stating that

*water moved into the potato cells from the sugar solution because the 1.0 M solution has more water molecules than in the potato tissue. The potato cells lost water in solutions above 1.0 M because the cells have more water molecules inside than the solution.*

The majority of candidates was able to correctly name osmosis as the process responsible for the results in Part (c) (iii), and gained the mark for correctly suggesting a possible error in the experiment. Candidates were expected to suggest factors such as *strips not of equal weight before immersion, all strips not allowed the same time for immersion, concentrations of sugar solutions not accurate or evaporation of liquid if not covered*.

Part (d) was especially challenging for candidates who were not familiar with the differences between the structures of plant and animal cells and had little or no practical experience observing the appearance and behaviour of these cells in solutions of different concentrations. In Part (d) (i), candidates were expected to account for the differences by stating that *the animal cell would burst in pure water but the plant cell would not because animal cells have a cell membrane which cannot withstand the internal pressure as the cell gains water and its cytoplasm expands. Plant cells, however, have a cell wall which can withstand the pressure and prevent the cell from bursting.*

Part (d) (ii) required that candidates explain why the appearance of an animal cell would differ from that of the plant cell after immersion in concentrated sugar solution for 30 minutes. The correct response was that *animal cells shrink as their cytoplasm lose water but the cytoplasm in a plant cell shrinks away from the cell wall and becomes plasmolysed as it loses water.*

The majority of candidates who got Part (c) (iii) correct named diffusion or active transport as another process by which substances can move in and out of cells, for Part (e).

Part (f) asked candidates to give two reasons why living organisms need to move substances in and out of their cells. Those candidates who named processes that take place within cells such as respiration, or said *to remove harmful or waste substances, or to obtain materials for growth or for support or homeostasis* were awarded full marks.

## Question 2

This question tested candidates' knowledge of the anatomy of the human digestive system and how the system is adapted to carry out its functions. The mean of this question was 6.8 and the mode was 5, out of a maximum of 15 marks.

Part (a) required that candidates identify five of the structures labelled in a diagram of the human digestive system. This part of the question was very well done with most candidates scoring full marks for correctly labelling *the stomach, small intestine, large intestine, liver and pancreas*. Unfortunately, in several cases; the terms were not spelt correctly and teachers are being reminded to emphasize the importance of the correct spelling of biological terms when preparing their students.

In Part (b), candidates were asked to suggest three ways in which the structure labelled B, the small intestine, is adapted to carry out its functions. This part was also well done by most candidates who stated that *it is long, and has thousands of villi providing a large surface area, many capillaries and thin walls to carry out its absorptive function.*

Part (c) was the most challenging section of the question. Candidates were required to suggest how the human digestive system is adapted to break down the different types of food eaten by humans who have an omnivorous diet. They were expected to relate the various named enzymes to the different components (for example, *proteases break down the proteins from meats, carbohydrases break down the carbohydrates from plant foods*) and to explain that *there are various types of teeth and different pH conditions in different regions of the alimentary canal.*

In Part (d) (i), most candidates were able to score full marks for correctly stating that *a digestive function of the liver is to produce bile for emulsifying fats*, and *that of the pancreas is to produce pancreatic juice or enzymes to digest food*. A few candidates gave responses that were not digestive functions, such as breaking down toxins by the liver and insulin production by the pancreas.

In Part (d) (ii), most candidates were able to suggest at least one of the two consequences of the malfunctioning of the pancreas, that is, *digestion would be impaired* or *enzyme supply would be reduced*. They were also expected to state that insulin supply would be reduced causing impaired sugar metabolism or diabetes or low blood glucose levels if glucagon was named.

### Question 3

This question tested candidates' ability to describe the inheritance of sex in humans and identify the parts of a flower where sex cells are found. It also examined their knowledge of meiosis, monohybrid inheritance and variation. Performance on this question was generally poor as several candidates were unfamiliar with these biological concepts and provided no response to the entire question or parts of it. The mode was two and the mean was four, out of a maximum of 15 marks.

In Part (a), candidates were required to complete a table to illustrate how sex is inherited in humans. The better prepared candidates were able to state the male parental genotype as XY and the gamete genotype of males as either X or Y, while that of the female are all X. The offspring genotypes would be XY for the male offspring and XX for the female offspring.

Part (b) required candidates to label a diagram of a flower to show where sex cells are found. This part was well done as candidates were able to label the ovary and anther correctly. Part (b) (ii) was poorly done as very few candidates were able to describe the process of meiosis. Candidates' responses were expected to include *the pairing of homologous chromosomes, crossing over taking place, the separation of the homologous pairs in the first division and the separation of sister chromatids by the end of the second division*. Most candidates mentioned that each gamete formed had half the number of chromosomes found in the parent cell. These candidates were generally able to recognize that four chromosomes would be found in the gametes produced by a plant whose diploid chromosome number is eight.

In Part (c), most candidates were able to correctly suggest that variation would occur because of meiosis and this is useful to help plants adapt to changes in the environment. Another way the process is useful is that it allows the species chromosome number to be retained after fertilization involving the gametes.

Part (d) tested candidates' knowledge of monohybrid inheritance and their ability to use a genetic diagram to explain why more red flowers than white flowers were obtained when a red-flowered plant was crossed with a white-flowered one. This part of the question was fairly well done by the better prepared candidates who recognized that the red parent flower had a heterozygous genotype, Rr and the white flower was rr. A few candidates did not state the phenotypic ratio of the offspring as 1 red: 1 white flower.

Part (e) tested candidates' knowledge of the impact of environmental factors on genetically identical organisms. This part was well done and candidates explained that factors such as *differences in soil types, the amount of water given, exposure to sunlight* and *use of different types of fertilizer* could account for differences in the size of the flowers, even though they had the same genotype. A common misconception was that the differences arose because of mutations.

#### Question 4

This question tested candidates' knowledge of photosynthesis and how the external features of a green dicotyledonous leaf are adapted to aid the process. It also examined their knowledge of decomposers and their ability to distinguish autotrophic from heterotrophic nutrition, as well as their ability to think critically and suggest advantages and disadvantages to plants when their leaves fall. Candidate performance on this question was generally poor. The mode was one and the mean was five, out of a maximum of 15 marks.

Part (a) examined candidates' knowledge of photosynthesis in green plants. A few candidates were able to give an accurate description of photosynthesis and many only stated a balanced chemical equation to summarize the process. A few were unable to clearly describe the roles of light, chlorophyll and water and some described the process of respiration instead. A candidate response that was awarded full marks was:

*Photosynthesis is the process by which green plants make their own food. Green plants use the sunlight energy they absorb, together with water and carbon dioxide to produce carbohydrates to sustain themselves as well as other animals, for example, herbivores and omnivores.*

*Equation for photosynthesis:*

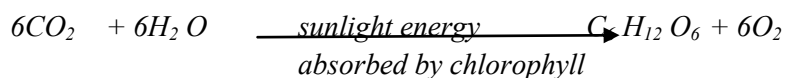

*Photosynthesis takes place in two stages:*

*First stage — light reaction for photosynthesis: Plants use the sunlight energy they absorb to split the water molecules into hydrogen and oxygen.*

*Second stage — light independent stage: Plants use the hydrogen they obtained in the light dependent stage and combine it with carbon dioxide to get glucose.*

In Part (b), candidates were asked to explain (with the aid of an annotated diagram) how the visible external features of a green dicotyledonous leaf aid in photosynthesis. This section was poorly done by most candidates. It was apparent that several candidates did not read the question carefully and drew diagrams of the internal structure of the leaf. Only representative drawings of the external structure which illustrated at least three of the following features were awarded all three marks allotted to the question:



- Broad lamina that provides large surface area to capture as much sunlight as possible
- Thin, to allow gaseous exchange to occur as quickly as possible
- Veins to keep the leaf surface flat
- Transparent waxy cuticle to reduce water loss from the upper surface
- Green colour indicating the presence of chlorophyll to trap sunlight

In Part (c) (i), candidates were required to name the microorganisms that feed on the leaves which have fallen from plants. Most candidates identified these organisms as decomposers and were awarded only one of the two marks allotted to that question. Candidates who stated bacteria and fungi were awarded full marks. Part (c) (ii) asked candidates to explain how the type of nutrition carried out by these organisms differs from the process of photosynthesis. This part was especially challenging for candidates who were unfamiliar with how decomposers feed. Candidates were expected to know that

*decomposers feed by breaking down complex organic substances to simple ones and this is a form of heterotrophic nutrition, unlike photosynthesis which involves simple inorganic substances being used to make complex organic substances (autotrophic nutrition). No chlorophyll or sunlight is required for this process, as is the case with photosynthesis.*

Part (d) required that candidates suggest two advantages and two disadvantages to a plant when leaves fall from it. Expected responses were *reduced transpiration/water loss, provide nutrients to the soil when decomposed and form leaf litter which protects the soil underneath by reducing soil erosion*. The disadvantages expected were *reduced surface area for photosynthesis and less chlorophyll*.

### Question 5

This question examined candidates' knowledge of the structure and function of the heart in circulating blood, as well as the role of vaccinations, methods of prevention, treatment or control of diseases of the heart and blood vessels and the role of white blood cells. Performance on this question was very poor. The mean for this question was three and the mode was zero, out of a maximum of 15 marks.

Most candidates were unable to draw representative diagrams of the heart as was required in Part (a). Candidates were expected to show the position of the pulmonary vein and vena cavae leading into the two upper chambers (left and right atria respectively); the bicuspid and tricuspid valves and the left and right ventricles; the semilunar valves; the aorta and pulmonary artery. Candidates were able to correctly explain that *the contraction of the heart muscles allows blood to be moved from the left atrium, to the left ventricle and out to the rest of the body through the aorta*. The role of the bicuspid and semilunar valves in preventing the backflow of blood in the heart was also mentioned.

In Part (b) (i), candidates were generally able to suggest that vaccinations would not be effective in the prevention, treatment or control of most diseases of the heart and blood vessels because *these diseases are physiological and may be caused by poor diet, which are high in fat and cholesterol, lack of exercise and birth defects but vaccines contain weakened antigen or antibodies and are effective at managing infectious diseases*. They were less likely to gain full marks in Part (b) (ii) because it was apparent that they had misconceptions about the role of white blood cells, such as that these cells aid in blood clotting.

Correct responses to this section should explain that *after surgery, the patient is susceptible to infections and white blood cells play a role in immunity. Also, phagocytes aid the healing process by quickly engulfing disease-causing bacteria, and lymphocytes help by producing antibodies to fight infective agents.*

### Question 6

This question tested candidates' ability to distinguish between a *community* and a *habitat* and examined their knowledge of appropriate sampling techniques, feeding relationships and factors that could disrupt the natural balance in an ecological community. Candidate performance on this question was fair with a mean of approximately seven and a mode of six, out of a maximum score of 15.

Most candidates were able to correctly state in Part (a) (i) that the term *community* refers to *a number of different species within a particular ecosystem or habitat* but the term *habitat* is *the type of place where a particular organism may be found such as a pond, lake, forest or desert*. Part (a) (ii) was more challenging for candidates, especially those with little or no practical experience doing ecological studies. This section required that candidates describe the sampling techniques that students could use to investigate the distribution of species in a forest and in a pond. Candidates were expected to describe how they would use a line transect across the area of a forest and observe or count the species at regular intervals along the transect; and also describe how they would either sweep or drag a net through the water in the pond and observe or count organisms collected in the net or in a jar.

In Part (b), candidates were expected to describe two types of feeding relationships that exist in an ecosystem and give an example of each. This was well done by most candidates.

Most candidates were also able to construct a food web or chain which described the trophic relationship among at least four organisms in a community in Part (b) (ii). A few were, however, unable to state that the organism(s) at the top would have the least amount of energy available.

Part (b) (iv) asked candidates to describe two ways in which the natural balance in a community may be disrupted. This was well done by several candidates who identified the disruptive impact of pollution, disease, migration and drastic changes in the climate.

### **Paper 032 – Alternative to School-Based Assessment**

This paper assessed the range of practical skills required of biology students and consisted of three compulsory questions. Although there was significant improvement in the performance during this sitting of the examination, candidates continue to display weak practical skills especially in aspects of planning and designing including the assembling of apparatus, describing methods of experiments and in drawing conclusions from data. These observations reinforce the need for teachers to provide opportunities for candidates to develop their practical skills. Once again, the examining committee reiterates that candidates must be exposed to actual experimenting and investigating scientific phenomena, discussions,

explanations and rationalizing of procedures and outcomes so that they become capable of developing and manipulating experiments and experimental data on their own.

### Question 1

This question tested candidates' knowledge and understanding of simple controlled investigations involving respiration and food tests. Candidate performance on this question was reasonable. The mean was approximately seven out of the 17 marks available, while the mode was 6.

Parts (a), (b) and (c) examined candidates' ability to use data relating to apparatus used to investigate respiration in woodlice and to calculate the total distance travelled, the average distance of a drop of oil, and the volume of oxygen used by the woodlice in one minute. Several candidates recognized that they were expected to add the figures relating to the distance moved by the drop provided in the table to get the total distance travelled in Part (a). They were then expected to divide this total by 6 to get the distance travelled by the drop of oil in one minute in Part (b), and then multiply this value by 0.5 to calculate the volume of oxygen used by the woodlice in one minute.

In Part (d) (i), candidates were asked to predict the outcome of the experiment if it was carried out at a higher temperature. Most candidates were able to respond that the respiratory enzymes would work faster or the rate of respiration would increase. These candidates were also likely to suggest another variable that could influence the results of the experiment in Part (d) (ii). The responses that were awarded marks included *pressure, moisture, number of woodlice* or *the activity level of woodlice*.

In Part (e) (i), candidates were required to use their knowledge of food tests to identify the components of the diet of a small mammal. This section was poorly done by candidates with limited or no experience in carrying out food tests. While most candidates were able to correctly state the expected results of the food tests they described, they were rarely able to describe the correct procedure (including the correct reagents) for carrying out the food test. Candidates were able to predict the relative amounts of protein, carbohydrates and fat if the mammal was a carnivore or a herbivore as was required in Part (e) (ii). Most candidates recognized that the diet of the herbivore would have more protein and fat but very small quantities of carbohydrate if any was present while the diet of the carnivore would have mostly carbohydrates and smaller quantities of protein or fat if any was present.

### Question 2

This question assessed candidates' knowledge of experiments designed to investigate photosynthesis as well as their planning and designing skills. Candidate performance on this question was poor. The mean score was approximately seven out of a maximum of 29 marks and the mode was six.

Part (a) (i) examined candidates' knowledge of why plants should be destarched before investigating photosynthesis. A good response that earned full marks was:

*The plant was kept in the dark so that it would use up the sugars (starch) it had stored and there would be no photosynthesis and hence starch before the start of the experiment.*

For Part (a) (ii), most candidates were familiar with the fact that the role of soda lime in Jar A was to remove carbon dioxide. They were also able to outline the correct procedure for testing a leaf for starch in Part (iii). A common misconception noted was that the leaf was boiled in water to remove the chlorophyll. Teachers are being encouraged to emphasize to students that the purpose of alcohol is to dissolve the chlorophyll. They also need to remind students that alcohol is flammable and should not be heated directly with the bunsen burner as was stated by some of them.

Part (a) (iv) required that candidates explain which of the jars would most likely test positive for starch. Most candidates recognized that the leaves of the plant in Jar C would contain starch because it had all the conditions needed for photosynthesis.

Part (a) (v) was especially challenging for candidates with little or no experience with planning and designing experiments. Candidates were expected to state a hypothesis for the experiment outlined but instead stated an aim for the experiment. Two examples of hypotheses that earned full marks were:

*If there is no carbon dioxide then photosynthesis will not occur.  
The plant will not produce starch if carbon dioxide is not available.*

Part (b) was generally poorly done by most candidates. In Part (b) (i), candidates were required to make a drawing to show how the pieces of apparatus given may be assembled to collect data on the effect of light intensity on the rate of photosynthesis. Candidates who had experience in doing similar investigations were better able to make accurate drawings that showed the beaker containing water and an inverted funnel over the pondweed fully immersed in the water; the test tube inverted over the funnel and the light source placed at a distance — measured by the ruler — from the beaker. These candidates were also more likely to get full marks in Part (b) (ii) for stating that

*exposure to the light source at a particular distance, for a set period of time, would result in oxygen bubbles being given off. These bubbles could then be counted and the number recorded as a measure of the rate of photosynthesis. By varying the distance of the light source from the pondweed in the beaker, the light intensity would change and the number of bubbles could be counted and recorded.*

Candidates were awarded for neat tables drawn with a ruler and enclosed, in Part (b) (iii). They were only able to get full marks if they gave appropriate titles and row and column headings (such as *distance of light source and number of oxygen bubbles*).

Most candidates were awarded full marks for stating two examples of variables that could also affect the results in Part (b) (iv), namely, *temperature, amount of chlorophyll/number of leaves on pondweed or carbon dioxide concentration*. However, Part (b) (v), which required them to state two limitations, was more challenging. Candidates were awarded marks for this section if they included *heat from the light source, faulty stop watch or light source or measurement errors*.

Part (b) (iv) tested candidates' ability to design a suitable control for the experiment. The use of boiled pondweed or the setting up of the apparatus with no pondweed were awarded full marks.

### Question 3

This question examined candidates' drawing as well as their manipulation and measurement skills. Candidate performance on this question was poor. The mean was approximately five out of 14 marks and the mode was four.

In Part (a), candidates were required to make a labelled drawing to show how the long bones taken from the upper limb of a small mammal would appear if they were joined together. A sample of a candidate's drawing that was awarded full marks is shown in below.

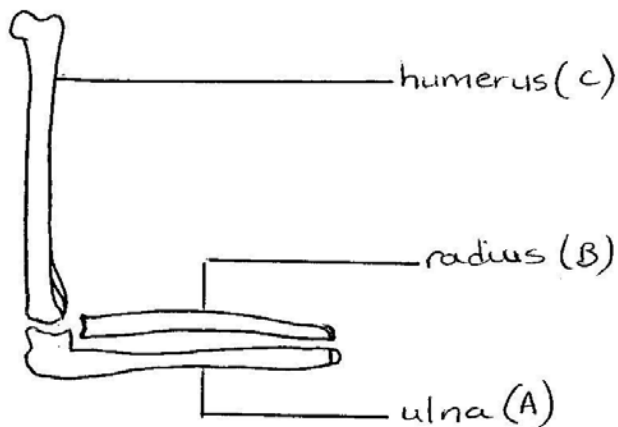

DRAWING OF THREE BONES, A, B AND C SHOWING HOW THEY WOULD BE JOINED TOGETHER IN A MAMMAL.

Candidates are being reminded that biological drawings should

- be done using pencils
- have clean continuous lines
- be drawn at a reasonable size (occupy at least half of the space provided)
- be accompanied by a title that is positioned under the drawing indicating the actual name of the specimen
- not be shaded
- have label lines drawn with a ruler and these lines should not cross each other, nor have arrow heads.

In Part (b) (i), candidates were expected to use a ruler and accurately measure the length of the neural spine of the two vertebrae provided in the drawings. Most candidates were able to do this but several were unable to suggest a reason for the difference in their lengths. The expected response was that the

*function of the neural spine is for support muscle attachment and the muscles differ in size in different regions of the back.*

Part (b) (iii) also tested candidates' ability to measure the diameter of the centrum of the vertebra labelled D. Most candidates were able to do this accurately but had difficulty stating the importance of the large centrum. They were expected to state that *the large centrum supports the weight of the body.*

Several candidates were unfamiliar with the vertebrae and were unable to correctly identify the vertebra labelled D as the lumbar and the one labelled E as a thoracic vertebra.

**C A R I B B E A N      E X A M I N A T I O N S      C O U N C I L**

**REPORT ON CANDIDATES' WORK IN THE  
CARIBBEAN SECONDARY EDUCATION CERTIFICATE<sup>®</sup> EXAMINATION**

**MAY/JUNE 2012**

**BIOLOGY  
GENERAL PROFICIENCY EXAMINATION**

**Copyright © 2012 Caribbean Examinations Council  
St Michael, Barbados  
All rights reserved.**

## GENERAL COMMENTS

The June 2012 examination in Biology at the General Proficiency level was the 42nd sitting of this subject conducted by CXC. Biology continues to be offered at both the January and June sittings of the examinations. The Biology examination is one of the more popular of the single sciences offered by the CXC at the CSEC level and assessed the performance of approximately 17,000 candidates this year. The examination comprises four papers: Paper 01 – Multiple Choice; Paper 02 – Structured/Extended Essay paper; Paper 03, the School-Based Assessment (SBA); and Paper 032 Alternative to the SBA (offered only to private candidates).

The overall performance of candidates this year was similar to that of last year with candidates scoring across the full range of marks in almost every question. Several candidates demonstrated better than adequate knowledge of fundamental biological concepts and principles relating to the structure of cells, digestive enzymes, joints of the human skeleton, the role of vectors in the transmission of pathogenic diseases and sexual reproduction in humans. Topics such as genetics, sexual reproduction in flowering plants and practical-based questions which required candidates to plan and design experiments or make drawings, still presented major challenges for many candidates.

Some improvement was seen in candidates' test-taking techniques as more candidates were able to give concise responses in the spaces provided without repeating the question. It was evident from the quality of many responses that candidates are being encouraged and guided by teachers in practising how to interpret and answer questions clearly and to the point. This suggests that some attention is being paid to the recommendations being given in the reports by the Biology examining team over the years. To ensure that these improvements are sustained, however, attention must be paid to the comments reiterated below in preparing the candidates.

- Teachers should try as much as possible to dedicate adequate time to the teaching of all aspects of the syllabus. It appeared that several candidates were not familiar with important topics in Section C of the syllabus and consequently were unable to respond to the genetics questions.
- Biological jargon should be used where appropriate and the spelling of biological terms must be correct in order to be awarded marks.
- Teachers should ensure that students are familiar with the meaning of terms listed in the glossary of the Biology syllabus, such as 'annotate', 'compare', 'describe', 'design' and 'explain'.
- A constructivist approach to the teaching and preparation of Biology students will enhance their ability to explain their ideas, clarify content and get them more engaged in problem-solving activities. It was evident that some candidates were learning content by rote, as these candidates were usually unable to adequately respond to questions that required them to apply their knowledge.
- Practical activities should be used to support the teaching of theoretical content and not treated as a separate activity. Practical skills, such as drawing, analysis and interpretation, and planning and design in particular, should be developed as part of regular class proceedings and not just given attention in a laboratory-type setting. The consistently poor performance in practical skills observed in the moderation of SBA and the inability to score full marks for most practical-based questions suggest that candidates were not given sufficient opportunity to develop their practical skills.



## DETAILED COMMENTS

### PAPER 01 – Multiple Choice

Paper 01 consisted of 60 multiple-choice items. Performance on this paper was satisfactory and quite similar to that of last year.

Some of the topics that were most problematic for candidates were:

- The role of bacteria in the nitrogen cycle
- Reflex arc and reflex action
- Surface area to volume ratio

### Paper 02 – Structured and Extended Essays

Paper 02 consisted of six questions, three of which were in the structured response format and three in the extended essay format. This paper tested all profile skill areas identified in the Biology syllabus. All questions were compulsory. Candidates' performance on this paper was similar to that on the June 2011 paper. Candidates were able to gain marks across the range for almost all questions and the mean for almost every question was relatively close to the mid-point of the range. Question 4 (Genetics) was a notable exception.

#### Question 1

This question examined some important practical skills, including candidates' ability to construct tables to record data, analyse graphical data and plan and design experiments. It also tested candidates' understanding of the properties and functions of enzymes in humans and plants, and the benefit of food storage in plants. The mean was approximately 10 out of 25 marks and the mode was 9.

In Part (a), candidates were given a graph illustrating the effect of temperature on the rate at which starch was broken down by the enzyme amylase. Part (a) (i) required candidates to construct a table to represent the data shown on the graph using four temperature values. Most candidates seemed aware of the general format of tables and were able to score at least three of the four marks allotted to this part of the question for giving appropriate column headings (which included units of measurement for temperature ( $^{\circ}\text{C}$ ), and mass of reducing sugar produced (mg per minute)), correct values and for drawing the table enclosed. Only those candidates who included an appropriate title were awarded full marks for that part of the question.

Part (a) (ii) tested candidates' ability to describe the trends in enzyme activity illustrated in the graph. Several candidates were able to gain at least two marks for stating that *enzyme activity increases between 10  $^{\circ}\text{C}$  and 35  $^{\circ}\text{C}$  and decreases between 35  $^{\circ}\text{C}$  and 55  $^{\circ}\text{C}$* . Candidates who also mentioned that the *rate of reaction (or enzyme activity) is highest (optimum) at approximately 35  $^{\circ}\text{C}$*  were awarded full marks. A response that was awarded full marks was:

*“Enzyme activity increased with increasing temperature up to the optimum temperature (35  $^{\circ}\text{C}$ ) which is evident by the steep slope. Enzyme activity decreased as temperature increased above the optimum temperature.”*

In Part (a) (iii), candidates were required to explain what happens to the enzyme at temperatures above 37 °C. Most candidates scored only one of the two marks for mentioning that the *enzymes were denatured*. Only a few candidates further explained that this was because *enzymes are proteins or that at temperatures above the optimum the enzyme active site is altered so it can no longer react with the substrate (starch) to break it down*.

Part (b) of the question asked candidates to design an experiment to determine the rate at which starch is broken down under different pH conditions. This was especially challenging for those candidates who had little or no experience in planning and designing experiments. Candidates' descriptions of their experiment usually mentioned that they would prepare/label different containers with equal amounts of solutions of different pH values (at least one acidic, one neutral and one alkaline), then they would add the same amount of starch mixture/sample to each container. Many candidates then said they would add amylase to the mixture and start timing the reaction. The better candidates further said that at regular time intervals thereafter, they would remove and test a sample of the mixture with Benedict's reagent for the presence of simple sugars. An alternative procedure that was poorly explained by candidates was to add iodine. If iodine were used, they were expected to mention that that would be done before amylase was added. After adding the enzyme to each mixture, they would use a timer to observe how long it took for the blue-black colour to disappear, which would indicate that starch is being broken down.

Candidates usually scored full marks for correctly naming two parts of the human digestive system where amylase may be found (the mouth and duodenum or pancreas) in Part (c) (i). However, many candidates were unable to fully explain why the digestion of starch stops when food reaches the stomach in Part (c) (ii). Although most of them mentioned that inside the stomach was acidic, only those who further explained that *the acid denatures the amylase preventing further digestion of starch* scored full marks. A common misconception was that starch was completely digested in the mouth so there was no further need for it in the stomach. Several candidates correctly identified pepsin or rennin as enzymes that work best in the stomach in Part (c) (iii).

In Part (d) (i), candidates were asked to suggest three plant structures in which amylase may be found. Candidates were expected to apply their knowledge of plant organs which store starch to give a correct response. While several candidates were able to score full marks for responses which included *storage organs, seeds, fruits and leaves*, a few mentioned phloem, xylem and even cell walls, which were incorrect. Most candidates were usually able to get one of two marks in Part (d) (ii) for indicating that *starch is broken down/ converted to a simple sugar which is transported in phloem*. Only those who also mentioned that *amylase changes the starch to simple sugars* were able to get full marks. Part (d) (iii) required that candidates give one benefit of the storage of starch to plants. This was well done by most candidates who were awarded the mark for mentioning *growth, growth of embryo during germination, sexual or vegetative reproduction, and overcoming the need for the continuous manufacture of food*.

## Question 2

This question tested candidates' knowledge of the structure and function of the various parts of a hinge joint. Performance was good. While candidates' scores were distributed across the full range of marks available for the question, their performance showed a mean and mode of 7 out of 15.

Part (a) (i) required candidates to state the names and at least one function of each of the three structures labelled in the diagram of a hinge joint found at the elbow in a human body. This part of the question was poorly done by most candidates. Responses should have included the name of any of the bones of the elbow such as *the humerus/radius/ulna*; and should have given one function of the bone named: *movement/support/blood cell production*. Those who simply labelled Structure A as bone were not awarded the mark. Many candidates were unable to correctly identify the structure labelled B as ligaments, whose function is to connect bone to bone. However they were usually able to give the correct name of the structure labelled C as synovial fluid. Only candidates who stated that its function is *to lubricate the joint/reduce friction/absorb shock/allow smooth movement* were awarded marks.

In Part (a) (ii), candidates were asked to use a line and the letter D to show cartilage on the diagram of the hinge joint. This part of the question was well done as most candidates labelled the structure at the end of the bones in the region of the joint.

Part (b) tested candidates' ability to explain how the wearing away of cartilage would affect joints. Most explained that the wearing away of cartilage results in *absence of shock absorbers and so the force goes directly to bones; bones rub together thus causing pain*. A response that was awarded full marks was:

*"If the cartilage is worn away, there won't be a padding to absorb the shock created by joint movements. Thus, the joints will rub together continually by friction causing pain."*

In Part (c), they were asked to explain how the muscles of the upper arm bring about the raising and lowering of the lower arm. This was poorly done by many candidates who often confused the muscles. A common misconception was that when the biceps in the upper arm contract, the triceps in the lower arm relaxed and vice versa, instead of triceps in the upper arm. A good response to this part of the question was:

*The biceps and triceps of the upper arm are antagonistic muscles. When the biceps contracts and the triceps relaxes, the lower arm is pulled towards the upper arm (lifted). However, when the triceps contracts and biceps relaxes, the arm is extended (lowered).*

Several candidates spelt the names of the muscles incorrectly and the examining committee suggests that teachers use a model of the arm/joints when teaching this topic.

In Part (d), candidates were to suggest why the treatment of some blood diseases may involve a bone marrow transplant. The expected response was that *red blood cells are made in the bone marrow of long bones; replacing these bones would ensure that healthy cells are produced which would stop the disease*. A good candidate response was:

*Since most blood diseases are caused by malfunctioning blood cells, most of which are made in the bone marrow, transplanting a healthy bone marrow in the person would aid the production of healthy blood cells consequently treating the blood disease.*

### Question 3

This question tested candidates' knowledge of the structure of plant cells. The mean and mode were 7 out of a possible 15 marks.

In Part (a), candidates were given a drawing of a typical plant cell with the major organelles and asked to identify and give the function of two of the cell structures labeled A and B. The majority of candidates were able to label A as the cell wall and B as the chloroplast; and the appropriate function was usually stated. A common misconception was that the cell wall allowed/controlled the entry and exit of substances within the cell. While several candidates recognized the cell wall as being 'permeable', it was not clear that they understood the implications of this, as they confused it with the selectively permeable cell membrane. Greater attention needs to be paid to clearly distinguishing between these two structures as well as to explaining the need for the cell wall in plants. The most common misidentification for the chloroplast was the mitochondrion and chlorophyll.

Part (b) of the question required that candidates draw an annotated diagram of the plant cell given in Part (a), to show its appearance after being left in concentrated salt solution for one hour. Many were able to make labelled, representative drawings of a plasmolysed plant cell but annotations – which are brief explanatory notes accompanying the labels of the drawing – were often missing or in some cases, written below the drawing. Some candidates accurately mentioned that *loss of water from the cytoplasm and vacuole of the cell would lead to shrinkage of the protoplasm and the pulling away of the cell membrane from the cell wall*. However, weaker candidates erroneously stated that the cell wall also would shrink or that the cell would swell and burst.

In Part (c), candidates were asked to explain why photosynthesis would be reduced if the cell is plasmolysed. This was not usually well done by candidates as many incorrectly said that chlorophyll/chloroplasts would be lost from the cell. Correct responses would have mentioned that *loss of water would reduce the supply of hydrogen needed to reduce carbon dioxide in photosynthesis and stomata would close, reducing the amount of carbon dioxide needed for photosynthesis to occur*.

Part (d) of the question was well done as candidates were able to identify the distinguishing features of plant and animal cells.

#### Question 4

This question examined candidates' knowledge of genetic terms and their ability to use genetic diagrams to identify the genotype of parents, given the phenotype of their offspring. This question was poorly done as illustrated by a mean of 5 out of 15.

Part (a) of this question assessed candidates' ability to distinguish between pairs of terms related to basic concepts in genetics namely: genes/alleles, genotype/phenotype and dominance/recessive. This was very poorly done as several candidates were unfamiliar with the terms. Candidates were expected to state that:

- (i) Genes are segments of DNA that carry information for making a specific protein or code for a specific characteristic, for example, fur colour in animals while alleles are alternative forms of a gene.
- (ii) The phenotype is the physical expression of the gene shown by an organism while the genotype consists of the combination of alleles of genes possessed by an organism. An example given could be black fur colour to represent the phenotype of a dog, and the symbols used to represent the alleles of the genotype could be Bb or BB.
- (iii) The term dominant is used to describe an allele that is expressed in the phenotype if the genotype is heterozygous while recessive is used to describe an allele that is expressed only in the homozygous genotype.

Some misconceptions were repeatedly observed in many candidates' responses to this part of the question. These were that:

- genes are chromosomes
- dominant genes are strong while recessive alleles are weak
- dominant alleles are more common than recessive ones.

In Part (b), candidates were required to use genetic diagrams to show the genotype of the parents and offspring of a cross, given that the phenotype of the parents was black and brown and the phenotypic ratio of the offspring was ½ black offspring to ½ brown offspring. This part of the question was usually well done by candidates who were knowledgeable about how to draw genetic diagrams. A response that gained full marks was:

Parental phenotype:                      black                      x                      brown  
 Parental genotype:                      **Bb**                      x                      **bb**  
 Gametes:                                      B              b              x              b              b  
 Fertilization cross:

	B	b
b	<b>Bb</b>	<b>bb</b>
b	<b>Bb</b>	<b>bb</b>

Since the ratio of the offspring is ½ black : ½ brown, the genotype of the parents must be **Bb** for the black fur colour male and **bb** for the brown fur colour female as shown above.

*If the black male parent was BB, then all the offspring would be black.*

In Part (c), candidates were asked to use a genetic diagram to show how two parents with normal phenotype could have a haemophiliac child, given that the gene for haemophilia is caused by an X-linked recessive gene. Candidates were expected to know that the female parent has two X chromosomes while the male parent has only one X chromosome. Since both parents were normal, one of the X chromosomes of the female carried the gene for haemophilia. They were also expected to infer that the Y chromosome will not carry the gene 'which was described as being X-linked. An example of a good response was:

Parents' genotype       $X^{H} X^{h}$                       x                       $X^{H} Y$   
 Gametes:                       $X^{H}$        $X^{h}$                       x                       $X^{H}$                       Y  
 Fertilization cross:

	$X^{H}$	$X^{h}$
$X^{H}$	$X^{H} X^{H}$	$X^{H} X^{h}$
Y	$X^{H} Y$	$X^{h} Y$

The genotype of the haemophiliac child is  $X^{h} Y$

### Question 5

This question tested candidates' knowledge of the life cycle of a named insect vector, pathogenic and physiological (lifestyle) diseases, and the socio-economic impact of AIDS on the Caribbean population. The performance on the question was good, with a mode and mean of 8 out of 15 marks.

Part (a) of the question required that candidates describe the life cycle of a named insect vector. This was generally well done as candidates correctly named either a mosquito or housefly and described the stages, namely, the egg, larva, pupa and adult. Candidates were also awarded a mark if all the stages were described in the correct sequence.

In Part (b), candidates were asked to distinguish between the mode of transmission of a named pathogenic and a named physiological (lifestyle) disease. Several candidates were able to give correct responses such as the following:

*Malaria is a pathogenic disease transmitted by a mosquito vector carrying plasmodium which causes the disease, from an infected person to others; whereas diabetes is a physiological disease caused by a malfunctioning pancreas which may result from a poor diet and lack of exercise but cannot be passed from one person to another.*

Part (c) tested candidates' knowledge of the difference in treatment and control methods for pathogenic as opposed to physiological diseases. Most candidates were able to get two of the four marks for explaining the difference in control methods for the two categories of disease but some had difficulty identifying appropriate treatment methods for the physiological diseases named. Candidates were expected to state that *pathogenic diseases such as influenza could be treated using vaccines or prescribed medications such as antibiotics but physiological (lifestyle) diseases such as diabetes or heart disease could only be treated by surgical procedures to correct the defective organ, or injecting special medications*. They were also to include that the control of pathogenic diseases involves preventing transmission by eliminating the insect vector at different stages of its life cycle, for example, *by removing stagnant water, throwing oil on the surface of stagnant water or using insecticides; or preventing infected persons coming in contact with uninfected ones; while physiological (lifestyle) diseases such as heart disease can be controlled by adopting a lifestyle which reduces exposure to risk factors such as not smoking, consuming diets low in salts and fats and exercising regularly*.

Part (d) required that candidates evaluate the socio-economic impact of AIDS on the Caribbean population. This was usually well done as candidates stated that AIDS is widespread in the Caribbean and consequently governments spend vast sums of money to help treat those who are infected, conduct research to find a cure and promote safe sex to prevent transmission. They also described how this reduced the amount of money available for other productive sectors such as education and agriculture, This also means that there is lower productivity in work places since large numbers of working people are infected with the disease. A high number of deaths led to a reduction in the labour force. The effect of loss of income due to job loss, discrimination and stigmatization were also correctly identified.

### Question 6

This question assessed candidates' knowledge of the human male reproductive system, methods of contraception that work by preventing fertilization and ovulation and the similarities/differences between the means by which the gametes are brought together in flowering plants compared with in humans. Performance on this question was good with a mean of 7 out of 15 and a mode of 6.

Part (a) required candidates to use a labelled diagram to: describe the structure of the male reproductive system; indicate on the diagram where gamete production occurs; and to label the structures involved in the transport of the gametes for reproduction to take place. There was tremendous variation in the quality of the drawings. Some candidates produced well-proportioned and correctly proportioned structures. Most candidates were able to indicate the *testes* as the site of sperm production and the *vas deferens*, *sperm duct/urethra* as being responsible for the transport of sperms.

Many candidates confused the functions and positions of the scrotum and testes. The urethra was confused with the ureter (associated with the kidneys). Candidates should be encouraged to use biological terms when labelling biological drawings. Incorrect labels are not awarded marks. For example, labels such as ‘balls’, ‘ball sack’ and ‘seed bags’ were sometimes used in labelling the scrotum and these did not gain any marks.

In Part (b), candidates were required to name one contraceptive method that prevents fertilization and one that prevents ovulation, and explain how each of the methods functioned to prevent pregnancy. Candidates who said *condoms (male or female)*, *diaphragm*, *spermicides*, *tubal ligation or vasectomy which prevent sperm from meeting with the ova*; and *birth control pills which contain hormones and prevent release of an ovum from the ovary* were awarded marks. Some candidates were unable to distinguish fertilization from ovulation and tubal ligation was often incorrectly said to prevent ovulation. Candidates who simply said ‘pills’ or ‘injection’ instead of contraceptive or birth control pills/injections, in responding to Part (b) (ii) were not awarded marks.

Part (c) required that candidates compare the means by which gametes are brought together in flowering plants with the means by which they are brought together in humans. This section was generally well done. Candidates were expected to compare pollination in plants with sexual intercourse in humans, and to compare the events leading up to fusion of the gametes (fertilization) in both plants and humans. The response should have been that *pollen (the male gamete of plants) is transferred from the anther to the stigma of the flower by pollinating agents, namely wind, insects, while sperm (the male gamete of humans) is transferred from the testes of the male to the vagina of females by means of sexual intercourse/copulation*. Candidates should also have stated that after pollination in plants, *the pollen grain germinates and two nuclei are produced*. A pollen tube is then formed which grows down the style, into the embryo sac, through the micropyle, carrying the male gametes to the ovum so fertilization could take place. In humans however, *sperm in the vagina swim through the cervix and up the uterus to the oviduct/fallopian tube where the sperm meets the ovum*. Candidates were also awarded marks if they mentioned that in humans, the ovum is released into the oviducts where fertilization takes place but in the case of plants, the ovum remains in the embryo sac and is fertilized there. Some candidates used a table to do the required comparisons and they were usually able to gain full marks for their responses.

Some candidates gained few marks because they spent time describing the structure of the gametes rather than explaining the means by which the gametes are brought together. Many candidates did not gain any marks because they incorrectly stated that plants reproduce by asexual reproduction while humans reproduce by sexual reproduction. Some incorrectly used the term sexual intercourse interchangeably with ovulation and fertilization and said that fertilization occurs in the ovaries and the uterus instead of in the oviducts. Other misconceptions were:

- gametes are produced by mitosis in plants while gametes are produced by meiosis in humans
- the anther fuses with the ovary in plants whereas sperms fuse with ovule released from the ovary or that the sperm fuses with the ovary
- the ‘anther’ and ‘pollen’ were used interchangeably and so were ‘ovary’ and ‘ovum’/ ‘ovule’

## Paper 032 — Alternative to the School-based Assessment (SBA)

This paper assessed most of the practical skills required of Biology students. Candidates continued to display weak practical skills, especially in aspects of planning and designing including manipulating apparatus, describing methods of experiments, identifying limitations and in drawing conclusions from data. These observations indicate that in developing practical skills students should be exposed to actual experimenting and investigating scientific phenomena, discussions, explanations and rationalizing of procedures and outcomes.

### Question 1

This question tested a range of candidates' experimental skills and their performance was generally poor. The mean for this question was approximately 5 out of 25 marks available.

Part (a) tested candidates' ability to use graph paper to determine the surface area of two leaves taken from two species of plants growing in a rainforest. Several candidates were unfamiliar with the counting of squares method that was required, and incorrectly tried to use the length multiplied by width formula to do the calculations. They also did not include the units of measurement.

In Part (b), candidates were asked to suggest which of the leaves would be found in an open area and give a reason for their choice of response. They were expected to indicate the leaf with the smaller surface area because *it reduces water loss in an open area*. If they chose the leaf with the larger surface and mentioned that it was adapted to capture a lot of sunlight in open areas they were awarded a mark.

Part (c) required candidates to outline how the apparatus shown could be used to compare the chlorophyll content of each leaf. This was challenging as many candidates had very poor planning and designing skills. They were expected to state:

- first use graph paper to measure the surface area of leaves collected from both plants
- measure equal masses of both sets of leaves
- use the mortar and pestle to grind the leaves up in separate containers
- put the ground leaves in separately labelled boiling tubes
- add equal amounts of alcohol to remove the chlorophyll from the leaves
- place the boiling tubes in a water-bath for an equal amount of time
- remove and hold against the plain white paper to compare the intensity of the green colour/chlorophyll from both sets of leaves.

In Part (d), some candidates constructed a table with suitable headings related to two sets of leaves and stated an appropriate title.

Part (e) was poorly done by candidates who stated precautions rather than limitations. Examples of limitations candidates could have mentioned include: *the small amount of alcohol used not being able to dissolve all the chlorophyll in the leaves using this method* or that *the same amount of chlorophyll may not be present in all the leaves of a particular plant used*.

Only a few candidates were able to write a suitable hypothesis as was required in Part (f). Most wrote an aim and gained no marks. An appropriate hypothesis was:

*Leaves of plants growing in shaded areas have more chlorophyll than those growing in open areas.*



For Part (g), many candidates gave adaptations that were unrelated to photosynthesis. Adaptations to trap as much sunlight as possible include: *having numerous branches and/or leaves, leaves arranged parallel to the ground, more chlorophyll in leaves, grow on taller trees as epiphytes.*

In Part (h), candidates were asked to plot data related to the length of the stem of seedlings. Most accurately plotted line graphs and presented a key. However, some candidates reversed the labels of the x- and y- axes, omitted the title and used an inappropriate scale.

## Question 2

This question tested the candidates' understanding of the usefulness of reflex actions as well as their planning and designing skills. Performance on this question was weak with a mean score of 6 out of a possible 19 marks.

Part (a) asked candidates to explain the usefulness of the knee jerk reflex arc which was illustrated in a diagram. Only a few candidates fully explained that testing this reflex could help to *determine how well someone is able respond to external stimuli or if their nervous system is functioning properly, or if someone's spinal cord has been injured.*

In Part (b), candidates were asked to explain how the reflex action would be affected if a footballer's knee cap is injured. A good response was that if the *tendon or nerve of the patella/knee cap were injured or damaged, there would be no reflex response and the knee would be stiff or immobile.*

In Part (c), candidates were required to describe how the knee jerk reflex could be used to test the hypothesis that "alcohol consumption interferes with the transmission of nerve impulse in a reflex arc". This part presented a challenge where many candidates discussed effects of alcohol on the nervous system instead of writing a procedure. A good response was that *the researcher would have an individual or group of volunteers consume a fix amount of alcohol while another individual or group of individuals would not consume alcohol; then each person would sit on the edge of a table with their feet hanging loosely and the researcher would hit the base of their knee cap then measure and compare the time taken for a response from each set of individuals.*

Part (d) (i) of the question required candidates to measure the diameter of the pupil of an eye after exposure to light of different intensities. This was well done by most but some candidates attempted calculations and a few measured the iris instead of the pupil and did not score any marks.

Part (d) (ii) tested candidates' ability to write a suitable aim for this investigation. This was also usually well done. An appropriate aim stated was:

*To investigate how light intensity affects the diameter of the pupil of the eye.*

In Part (d) (iii), candidates were asked to give one limitation in this investigation. Several candidates were awarded marks for stating that *a certain light intensity could not be exceeded because it would not be safe for the eyes* or that *it was difficult to measure the pupil*. Candidates were not awarded marks if they stated precautions for sources of error.

Part (d) (iv) required candidates to write a suitable conclusion from the investigation. Most gave the correct response that the *diameter of the pupil decreases with increased light intensity.*

Part (e) tested candidates' knowledge of the part of the eye responsible for controlling pupil size. Many gained marks for stating that the *iris controls the pupil* and described the function of either the circular or radial muscle in bringing about changes in the diameter of the pupil of the eye. Candidates who mentioned ciliary muscles which adjust the shape of the lenses of the eye, instead of circular and radial muscles were not awarded marks.

### Question 3

The question tested candidates' knowledge and understanding of breathing and gaseous exchange and ability to use data to construct a graph and a pie chart. Candidate performance in this question was fair. The mean mark was 7 out of 16 marks.

The stimulus material indicated that data were collected on the effect of exercise on the breathing rate of a group of 100 healthy male athletes. After exercise the average number of breaths per 15 seconds was measured. Part (a) required that candidates calculate the average number of breaths per minute for the first minute after exercise. Most candidates were able to multiply 6 breaths per 15 seconds by 4 to obtain 24 breaths per minute.

In Part (b), candidates were required to construct a graph to show the relationship between time and the average number of breaths per minute. This was well done with many candidates scoring at least three out of five marks. Some candidates failed to realise that they first had to calculate the average number of breaths **per minute** and not simply use the values from the table. Marks were awarded for accurately plotting data points and using an appropriate scale. However, the majority of candidates forgot to include a descriptive title such as *the effect of exercise on the breathing rate of athletes*. Candidates often confused the position of the two axes, placing the dependent variable (*breathing rate per minute*) where the independent variable (*time after exercise*) should be. Candidates need to be reminded to choose appropriate scales that will allow for maximum use of the graph page and to quote the units in the labels for the axes.

Part (c) required candidates to explain the shape of the graph. This was poorly answered, with only a few candidates able to say that *the breathing rate decreased after exercise as athletes recovered*; or *that after exercise, the breathing rate declined and returned to normal after nine minutes*.

In Part (d), candidates were given a table of data from a survey done on smoking. Candidates were required to construct a pie chart and show their calculations of the angles. The majority of the candidates did not show their calculations or simply re-calculated the percentages given instead of the degrees for each sector of the pie chart. A correct calculation was:

$$\text{Non-smokers: } 50/100 \times 360^\circ = 180^\circ \text{ and ex-smokers: } 15/100 \times 360^\circ = 54^\circ$$

It was evident that candidates were poorly equipped, having no geometry sets (protractor and compass). Marks were awarded for accurately measuring and proportionally representing the sectors, using a key or labelling the sectors on the pie chart and neatly drawing the sectors with a ruler. The majority of candidates neglected to include a descriptive title such as *Pie chart showing categories of smokers*.

In Part (e), candidates were expected to explain why smokers with emphysema would have a higher than normal breathing rate after exercise. This was poorly answered, as some candidates re-phrased the stimulus material as their answer. A few candidates were able to recognise that if the alveoli walls were covered by hard fibrous tissue, there would be *less surface area for gas exchange and less oxygen can be obtained from each breath*. Thus smokers have a higher breathing rate after exercise to compensate for the reduced gas exchange per breath.

## Paper 03 – School-Based Assessment (SBA)

### General Comments

Performance on the School-Based Assessment was commendable. Favourable trends observed included: good syllabus coverage (i.e. a minimum of nine syllabus topics covered) by most centres; an increase in the number of centres where both quantitative and qualitative fieldwork were done and the number of times practical skills were assessed complied with syllabus guidelines. This suggests that most teachers recognize the value of providing sufficient opportunity for students to develop and master all the specific practical skills. However, while the skill of Observation Recording and Reporting (ORR) was well done, Drawing (Dr), Analysis and Interpretation (AI) and Planning and Designing (PD) continue to present candidates with the most difficulty.

While the level of organization and presentation of books submitted from most centres was good, there were still some centres that submitted books without the requisite information. The CXC Biology syllabus (page 44) provides guidelines for candidates' preparation of practical laboratory books for submission. Some important requirements often **NOT** met include: a Table of Contents with aims of the practical activities, page numbers, dates, and a clear and specific indication of the activities used for SBA and the skills being assessed. In addition, the marks awarded for each practical activity must be indicated on the same page with the practical activity and not simply listed at the front or back of the books.

The lack of comments in the books, especially for skills performed poorly suggests that students are not being given adequate feedback on their progress throughout the period of study. Oftentimes only ticks are observed and the final score awarded for the skills but students appear unaware of their strengths or deficiencies.

The moderation exercise was often hampered by poor mark schemes. Teachers are being reminded that mark schemes must be legible and preferably bound together instead of on loose sheets of paper. There must be a clear and direct relationship between the marks awarded for the appropriate activities in the practical books and the marks on the tally sheets. It should also be noted that no more than two skills should be assessed in a practical activity. New teachers in particular should consult pages 38 – 44 of the Biology syllabus for guidance in preparing and presenting mark schemes.

The following is a list of criteria which teachers should follow in marking SBA activities:

- Marks should be awarded for each skill separately. It is noted that in some cases, marks were given for each skill then tallied to give a composite score. This is unacceptable.
- Marks awarded to students' work should be a fair indication of its quality. Too many students received high marks for work that fell short of the CXC standard. This was particularly noticeable for Planning and Designing, Analysis and Interpretation, and Drawing. When the CXC standard is not observed there is great disparity between the teacher's score and that of the moderator. This circumstance is usually disadvantageous to the students.
- Marks submitted on the moderation sheet should reflect the candidates' marks in each of the samples. Consistency of marking and submission of marks relate to the reliability of the process and thus acceptability of marks submitted.

- Teachers are once again reminded that body fluids such as saliva, blood and urine are not to be used for practical work. These can be sources of infection and may have serious legal implications should a student become infected while conducting practical work. Plant materials must be removed from books before they are submitted to CXC, since these are also potential agents of infection when moved from place to place.

The examining committee would also like to recommend that there be greater cooperation among teachers of similar subjects at the same centre and even among centres and mentoring of new teachers, to ensure consistency in standards is maintained.

A review of previous subject reports will provide additional suggestions for developing practical skills. Further suggestions are reiterated in this report and each teacher is alerted to the specific strengths and weaknesses displayed by their candidates in the moderation feedback form sent to schools from CXC, after moderation. The moderation feedback form, which is sent to each centre, provides constructive and useful information relevant to the particular teacher(s). This form offers specific recommendations and is intended to assist teachers in planning, conducting and assessing practical work – in the laboratory and field. Improvement of students' practical skills will have a direct influence on candidates' overall performance in the Biology examination, since certain questions, notably question 1 on Paper 02, are based on knowledge and application of these practical skills.

#### Specific Comments on the Assessment of Skills

The following information is to assist especially new teachers of Biology in interpreting the information given on the CXC Moderation Feedback Report.

The number of times a skill is assessed is considered sufficient if assessed a minimum of four times (see page 37 of the Biology syllabus).

#### Observation, Recording, Reporting (ORR)

This skill appears to have been mastered at most centres sampled. The method was clearly described with logical sequence of activities. It was also observed that except for a few centres, the past tense was correctly used in the presentation of the report on the practical activity (except for Planning and Designing, as required). Students should be encouraged to pay careful attention to grammar, quality of expression and giving as many details as possible when reporting procedures and observations. Where possible, students should also be encouraged to repeat procedures and give average results to improve the reliability of their results.

The tables and graphs were usually clear and provided adequate details which allowed for clear description and discussion of the experiment. The examining committee recommends that teachers give students more opportunity to construct their own tables and graphs using their results.

When constructing tables, teachers should remind students that the title should be written above the table using capital letters, the table must be enclosed and appropriate row and column headings should be given.

Example:

TABLE 1: FROG POPULATION OBSERVED FROM OCTOBER 1997 TO OCTOBER 2004

Year	Number of frogs
2004	5
2001	110
1997	125

When drawing graphs the title should be written below the graph and underlined; axes should be labelled, with units stated and a key should be presented if necessary.

If calculations are required, all necessary calculations should be shown and these should be done and presented neatly and in an organized fashion. Units should also be included where necessary.

Where drawings are used in reporting observations, they should meet standard SBA drawing criteria, even though the skill is not being assessed.

Drawing (Dr)

The quality of the drawings from most centres has shown some improvement, especially in relation to clarity. However, at too many centres poor drawings were awarded high marks. The examining committee does not expect drawings to be works of art, but they should meet the criteria for accuracy, proportions; clarity, labelling and magnification. Teachers should ensure that students are given many opportunities to practise and develop drawing skills.

It is a requirement that drawings must be produced from actual specimens and not from textbooks. Specimen **MUST** include drawings of flowers, fruits, storage organs and bones. Additional examples may be included in practical books. However, microscope drawings, models and apparatus should not be used for SBA assessment. Drawings of cells, while useful for teaching, should not be assessed at this level but if taught, the calculation of magnification should also be emphasized. Similarly, dissections may help students to understand structures such as the digestive system but they are too complex to be drawn accurately at this level. These difficult drawings do not provide a fair test of ability at this level.

Table 1 is a list of ‘Do’s and ‘Don’ts applicable to SBA biological drawings:

**TABLE 1. DOs AND DON'Ts OF BIOLOGICAL DRAWINGS**

Do s	Don't s
<ul style="list-style-type: none"> <li>• Use pencils for all drawing activities – drawing, label lines, labels.</li> <li>• Use drawings of actual biological specimens (not diagrams, models or textbook drawings); ensure for assessment there are drawings of flowers, fruit, seeds and bones.</li> <li>• Let the size of drawings be at least half of a page.</li> <li>• As far as possible, have label lines and labels positioned at the right side of the drawing.</li> <li>• Let all label lines end at the same vertical plane.</li> <li>• Let label lines be drawn parallel to the page top/bottom.</li> <li>• Ensure label lines end on the part being made.</li> <li>• Write the title in capital letters.</li> <li>• In the title, use word “drawing” and not “diagram”.</li> <li>• Position title under the drawing and indicate the actual name of the specimen (for example, cervical vertebrae of a goat, mango leaf, hibiscus flower) and the view drawn.</li> <li>• Underline the title.</li> <li>• Include the magnification and state, where appropriate, actual length and width of specimen as well as place ‘×’ in front of the magnification.</li> <li>• Write magnification to 1 decimal place.</li> <li>• Use a key to explain symbols where appropriate, for example, stippling/cross hatching.</li> </ul>	<ul style="list-style-type: none"> <li>• No arrow heads.</li> <li>• No crossing of label lines.</li> <li>• No dots or dashes.</li> <li>• Do not join letters of words for label or title.</li> </ul>

Accuracy and labelling continue to be problematic for candidates and there appears to be some degree of inconsistency — even among teachers at the same school — in how they are assessed. Label lines should be drawn with a ruler and as much as possible, labels should be written in script (not capitals) so that they can be easily read. Annotations should give the functions and descriptions of the structure where appropriate. Annotations that accompany drawings should be as brief as possible and clearly and neatly written.

The examining committee also encourages teachers to ensure that standard drawing criteria are applied whenever drawings are required in laboratory activities, especially when reporting observations and/or illustrating biological processes, for example, germination, regardless of whether DR skills are to be assessed or not. This should help students appreciate the importance of the skill.

Teachers should also ensure that students draw on plain paper and then neatly insert drawings into lab books, if the books are not designed with plain sheets of paper for drawing. Distinguishing features and labelling lines are oftentimes unclear when drawings are done on ruled sheets of paper.

### Analysis and Interpretation (AI)

This skill continues to present problems for the majority of candidates. Many teachers continue to use questions to stimulate discussion. This device is good for helping students to develop their AI skills. However, they should not be used excessively, nor should they be the only means of assessment. These questions must guide students to provide the required background information, give explanations for the results, draw conclusions and show an awareness of possible limitations. The information provided in this way should then be written as a paragraph of continuous prose as is normally done for the discussion/conclusion. In many cases, candidates seem to have learnt a formula for writing up the discussion but showed no real understanding of how to interpret their own results. As a teaching strategy, teachers may ask their students to orally explain the results to obtain a clearer view of their understanding and to help them develop their analytical skills.

The marking criteria used by some teachers did not include ‘limitations’. It was sometimes observed that precautions/control/sources of error were often accepted as limitations by the teacher.

The use of controls should also be emphasized as they are a point of comparison for the experimental set up in which a particular variable has been omitted. This comparison should be included in the discussion as it is the key to drawing the conclusion. Conclusions should relate directly to the aim of the investigation. Students should also be reminded to discuss at least one limitation of the investigation. It is important for them to recognize that the conditions present in a school laboratory are rarely ideal.

The processes involved in demonstrating the AI skill are reiterated here:

- Background information may be written in the “Discussion,” or in the introduction section.
- Background information for the experiment must be related to the theory.
- Discussion should be an analysis or interpretation of the recorded experimental results. Discussion must not simply answer posed questions for AI:
  - a. questions may be used to guide students but answers must be written in paragraph format (without the questions or written comprehension style)
  - b. questions should not to be included in the laboratory report.
- Conclusion must be based on the aim. (It is a brief answer to the aim.)
- Limitation(s) should be included among the AI marking criteria.
- Identifying source(s) of error and precaution(s) is necessary. These are both different from each other and from limitation(s).
- All components of AI (background knowledge, explanation of results, limitations and conclusion should be included in the mark scheme for the skill).

The examining committee is again reminding teachers that food tests on their own are not appropriate for assessing AI. Simple investigations can be designed in which food tests are used. For example, students can be given unknown mixtures and asked to find out which food would be most suitable for an infant. Food tests can be used also to determine the presence of a particular food before and after digestion by an enzyme. These types of exercises will allow students to develop the necessary skills. Knowledge of the food tests and the nutritional requirements can then provide the background information on which they will base their conclusions.

### Manipulation and Measurement (MM)

As has been the trend in previous years, this skill continues to be the one that most candidates appear to have mastery, (achieved mastery) based on the observation that most are awarded full marks. However, evidence such as performance on the practical question in the final examination suggests that these marks may be the result of lenient marking.

The examining committee recommends that teachers expose students to a wide range of apparatus. This would help to ensure candidates' manipulation skills develop and allow for a more fair assessment of students' competence in MM.

### Planning and Designing (PD)

Performance on this skill has shown some improvement relative to former years and teachers should be commended for demonstrating more creativity in the types of observations/problem statements provided to students on which to base their hypotheses and design their experiments. The examining committee continues to emphasize the importance of using examples from students' local environment as this will help students better appreciate how they can apply their biological knowledge and practical skills to solve problems they frequently encounter. Teachers are reminded that it is inappropriate to have students copy procedures from textbooks and reproduce them verbatim for assessing PD skills.

The experiments designed by the students from some of the centres indicated that there was some understanding of the procedures involved in planning and conducting an experiment but in some instances, there were no replicates in the investigations. There are still a few areas of difficulty where candidates were unable to state their hypotheses clearly and relate the aim to the hypothesis. A hypothesis is an explanation based on particular observations, about how things work or why something happens.

It is also important that development of the skill start with the commencement of the teaching of the syllabus. In many cases it was obvious that practical activities targeting the development of the Planning and Designing skill were among the last set of activities in which the candidates engaged prior to the examinations. The following is an example of how a planning and designing activity might be effectively developed.

#### Example:

This Planning and Designing activity submitted by one centre was based on the observation that "*A boy notices that all the trees around his yard except the grapefruit tree were infested with 'duck' ants*". The students were required to plan and design an experiment to determine what was responsible for the difference in infestation. An example of an appropriate hypothesis and a relevant aim for investigating the hypothesis was:



**Hypothesis:** *'Duck' ants do not feed on grapefruit trees because the leaves contain a chemical that repels the ants.*

**Aim:** *To find out which plant leaves 'duck' ants feed on*  
(The aim of the subsequent investigation could be: *To determine the presence of chemical X in different leaves.*)

There was a clear description of the materials and method. Students planned to use different leaves to see if the duck ants would respond as they do the grapefruit leaves. The 'duck' ants would then be placed in labelled containers containing the same number, sizes of leaves taken from a particular tree. A container with no leaves was an appropriate control. The measurable variable would be the number of 'duck' ants that leave or remain in each dish. Results would then be tabulated and subsequently discussed.

As stated by the candidates, one limitation may be that 'the chemical in the leaves that cause the effect on the 'duck' ants may be affected by the extraction'. Appropriate marks were awarded for the various aspects of the experiment.

**C A R I B B E A N   E X A M I N A T I O N S   C O U N C I L**

**REPORT ON CANDIDATES' WORK IN THE  
CARIBBEAN SECONDARY EDUCATION CERTIFICATE® EXAMINATION**

**MAY/JUNE 2013**

**BIOLOGY  
GENERAL PROFICIENCY EXAMINATION**

**Copyright © 2013 Caribbean Examinations Council  
St Michael, Barbados  
All rights reserved.**

## GENERAL COMMENTS

The June 2013 examination in Biology at the General Proficiency level was the 44 sitting of this subject conducted by CXC. Biology continues to be offered in both January and June sittings of CSEC examinations. The examination consists of four papers: Paper 01 – Multiple Choice; Paper 02 – Structured/Extended Essay; Paper 03 – School-Based Assessment (SBA) and Paper 032 Alternative to SBA, offered only to private candidates.

This year, the performance of more than 17,000 candidates was assessed. Performance in 2013 was similar to that of 2012 with candidates scoring across the full range of marks in most questions. Topics related to the functions of the eye, variation among species, plant response to stimuli and the endocrine system were problematic for several candidates. It was also observed that candidates' knowledge of ecological investigations was mostly theoretical and several private candidates seemed to lack practical experience in planning and designing experiments and producing accurate, representative biological drawings.

Teachers and private candidates should try as much as possible to cover all aspects of the syllabus, particularly sections C – Continuity and Variation, and D – Disease and its Impact on Humans. Biological jargon should be used where appropriate and the spelling of biological terms needs special attention as candidates sometimes were unable to gain marks because examiners were unclear if they knew what they were talking about.

Candidates should be encouraged to read questions carefully, underline key terms and review answers before submitting papers at the end of the examination.

Candidates and teachers are being encouraged to make use of the online resources available on the CXC's website: <http://www.cxc.org> such as Biology subject reports for previous CSEC biology examinations, exemplars and online tutorials via Notesmaster. It is also suggested that teachers adopt a constructivist approach to planning and teaching the subject and try to creatively tap into the digital literacy skills of their students by posting lectures on social media pages and including videos where practical activities are being demonstrated (especially if laboratory resources are unavailable). These strategies are likely to deepen students' appreciation for the subject as these resources support their ability to learn by catering to their different learning styles and serve to improve communication with teachers who can provide feedback in a more timely fashion – in ways that textbook resources, classroom-based lectures and lecture notes would not be able to.

## DETAILED COMMENTS

### Paper 01 – Multiple Choice

Paper 01 consisted of 60 multiple-choice items. Performance on this paper was quite similar to that of 2012. The items on this paper which were most challenging for candidates were those that tested knowledge of aspects of plant biology. These included those items which related to plant storage organs, transpiration and excretion in plants.

### Paper 02 – Structured/Extended Essays

Paper 02 consisted of six questions arranged into two sections. The first section consisted of three questions written in the structured response format and the second section consisted of three extended essay questions. Candidates' performance on this paper was similar to that 2012 and most of them were able to gain marks across the range for almost all questions.

### Question 1

This question assessed candidates' practical skills in constructing suitable tables for recording data and planning and designing experiments to carry out investigations. It also tested candidates' knowledge of the types and causes of variation and aspects of the transport systems of both humans and plants. The mean was approximately 10 out of the 25 marks and the mode was 8.

In Part (a), candidates were given a line graph showing the heights of a sample of men in a population and asked to construct a table using the data presented in the graph. Only a few candidates scored all three marks allotted to this part of the question for writing a title, column headings (Height (cm) in the first column and Frequency/Number of men in the second column) and recording data in the correct columns. Candidates were expected to record height measurements (instead of intervals) read from the graph provided. Candidates should be reminded to include the unit of measurement for example, *cm* beside the name of the variable in the column heading.

In Part (b), candidates were asked to suggest two causes of variation among members of the same species. Most candidates were able to score the two marks allotted for mentioning genetic factors such as crossing over during meiosis, random assortment of genes, mutations and environmental factors (such as lack of nutrients) as causes of variation. Some candidates incorrectly identified artificial and natural selection as causes of variation. These candidates did not understand these concepts. Natural selection is a process by which organisms with favourable characteristics survive and reproduce more successfully than those organisms which do not have these traits. Artificial selection is a process whereby humans select and breed plants and animals that have desirable traits. These species already have variable characteristics caused by the factors mentioned earlier but the selection process does not **cause** them to be different.

Part (c) required that candidates explain the difference in the type of variation shown in the data recorded in the table they constructed in Part (a), that is, heights of the men and variation in blood type among a class of 30 students. This was especially challenging for several candidates who were unfamiliar with the terms *continuous* and *discontinuous* variation. Candidates were expected to recognize that the height of the men varies continuously but blood groups vary discontinuously (exist in distinct categories), as well as explain that variation in height is influenced by the environment while variations in blood groups are not influenced by the environment.

Part (d) tested candidates' knowledge of the blood as the transport medium of humans. In Part (d) (i), most candidates were able to correctly name two substances (such as *oxygen*, *nutrients*, *hormones* and *antibodies*) that are transported by the blood. Candidates who named components of blood such as water, blood cells and haemoglobin were not awarded marks for those responses.

Part (d) (ii) required that candidates explain how a lower than normal amount of haemoglobin in the blood of three students would affect their ability to perform well in sports. Most candidates were able to score at least three of the four marks allotted for stating that *haemoglobin transports oxygen and oxygen is needed for (aerobic) respiration to provide energy for muscles to work*. Candidates who further explained that *exercise/sports increases the need for oxygen so low levels of haemoglobin would limit the ability of the students to perform well in sports or that these students would get tired more easily/feel pain due to lactic acid build up/experience oxygen debt due to low levels of oxygen uptake were able to score all four marks*. Two candidates' responses which scored full marks were:

*These students will not be able to perform in endurance types of sports as due to lack of haemoglobin, enough oxygen will not be transported in the blood and this oxygen is a necessity for muscles to respire and produce energy aerobically and they will have cramps as the body tries to respire anaerobically with lactic acid as a product and fatigue of muscles will result.*

*Haemoglobin is the substance that combines with and transports oxygen to sites of respiration. If the level is low it lowers the rate and efficiency of respiration as there is insufficient amounts of oxygen to provide the muscles during sports. Therefore the student will slow down quicker hence short of breath and have greater risks of muscle cramps due to lactic acid build up from anaerobic respiration.*

Responses that made reference to sickle cell anaemia, blood clotting and haemophilia were awarded no marks.

Part (e) tested candidates' planning and designing practical skills and was the most challenging part of the question. Several candidates scored less than half of the six marks allotted to this question. In Part (e) (i), candidates were required to draw and annotate a diagram to show how a list of materials given could be set up to investigate the rate at which water moves through xylem vessels under two different conditions. Most candidates were able to gain two of the four marks allotted to this part of the question for drawing two beakers with water poured to the same height and one plant with a transparent stem in each. Candidates were also able to gain marks if they indicated that the water in each beaker contained a dye and drew a fan directed at only one of the beakers. Marks were also gained by those whose drawings and annotations indicated that the ruler was used to measure the height of the coloured liquid in the transparent stem at regular time intervals.

In Part (e) (ii), candidates were asked to write a suitable hypothesis for this investigation. Several candidates were not awarded marks in this section of the question. The most common error made by candidates was writing expected results instead of a hypothesis. The poor performance on this question is an indication of the lack of experience candidates have in doing planning and designing practical activities such as writing a hypothesis as has been observed in the moderation of School-Based Assessments over many years. A hypothesis is an explanation based on a particular observation about how things work or why something happens. Expected candidate responses which would have gained full marks were:

*Transpiration is faster in moving air.  
Wind increases the rate at which water moves up xylem vessels.*

Part (f) asked candidates to relate the structure of xylem vessels to their role in the transport of water through plant stems. Candidates' were usually able to score at least two of the four marks for naming two features of xylem such as *hollow, 'thin' narrow tubes, cells joined end to end with no end walls or having lignin in the walls*. They were only able to gain full marks if they also stated how each feature named was related to the transport of water via xylem. A candidate's response that scored full marks was:

*Xylem is narrow so water can move up by capillary action quickly and the walls are made of lignin which prevents the xylem from bursting from the water pressure inside.*

A common misconception stated was that xylem is thin (instead of narrow) and this allows for fast diffusion and osmosis.

## Question 2

This question tested candidates' knowledge of the structure and functions of parts of the human eye, movement and response by both plants and soil invertebrates as well as their ability to distinguish between the nervous and endocrine systems in humans. The mean and mode were 6 out of 15 marks.

Candidates were given a diagram of the human eye in Part (a) and asked to name and use a label line to indicate the part of the eye which carries out the functions stated in Parts (a) (i) to (iv). Most candidates were able to score at least two of the four marks for correctly naming and labelling the retina as the light sensitive layer and the optic nerve as carrying nerve impulses to the brain. The vitreous humor — which is the jelly-like substance that keeps the eye in shape — and the ciliary muscles which control the shape of the lens were less well known. Many candidates spelt the labels incorrectly and could not be awarded marks. A common misconception was that the jelly-like substance that 'keeps the eye in shape' is the sclera.

Candidates who did not name the parts of the eye, as required, were not able to gain all four marks allotted even if the label lines were drawn correctly.

In Part (b), candidates were given two examples of plant movement shown by seedlings during growth. For Part (b) (i), they were asked to name the stimulus to which each set of seedlings was responding. This section was well done by most candidates. They were able to correctly identify *that the roots of seedlings growing downwards in the soil was in response to gravity or water while the shoots of the cucumber seedlings growing towards light coming through an open window was in response to light*. They were also able to state that auxins were the hormones responsible for the response of the cucumber seedlings in response to Part (b) (ii) but the spelling of *auxin* was sometimes incorrect. Most candidates also scored full marks for Part (b) (iii) for stating that the roots growing downwards was useful for anchorage in soil or to obtain water while plant shoots growing towards light allowed them to get optimum light for photosynthesis.

Part (c) required that candidates describe one similarity and one difference between the response of soil invertebrates to moisture and the response of the cucumber seedlings to light. It was observed that although many candidates were able to get two of the four marks allocated for stating that both cases were similar because their response or movement was directed towards a stimulus, few candidates were able to distinguish the type of movement shown by the invertebrates as *being whole movement* in contrast to the plant response as *part or growth movement*.

Part (d) asked candidates to outline two ways in which the nervous and endocrine systems function differently in humans. Most candidates scored full marks for giving correct responses to this section of the question. Correct responses frequently mentioned were that *the messages were in the form of electrical impulses/neurotransmitters in the nervous system but hormones carried messages in the endocrine system; impulses travelled via neurons in the nervous system but hormones travel via blood; messages sent via the nervous system were sent quickly but slowly in the case of the endocrine system; the effect of messages sent via the nervous system were usually short lasting but long lasting in the case of the endocrine system*.

### Question 3

This question examined candidates' knowledge of plants' excretory products, the structure and function of the human male reproductive system, contraception methods and the difference between asexual and sexual reproduction. The mean was 8 out of a possible 15 marks and the mode was 9.

In Part (a), candidates were required to name two metabolic waste products excreted by plants. Most candidates correctly named oxygen produced from photosynthesis, carbon dioxide produced from respiration, calcium oxalate or tannins, to score full marks. A common misconception was that leaves and blossoms are metabolic waste products.

Candidates were given a diagram of the human male reproductive system in Part (b) and asked to name the parts labelled A to C in the diagram in Part (b) (i). Several candidates were awarded full marks for naming the prostate gland (A), the testis (B) and the vas deferens/sperm duct (C). It was observed that many of them did not spell the names correctly. Some candidates lost marks for incorrectly identifying the part labelled B as the scrotum. Most candidates were also able to gain full marks for correctly using arrows to show the pathway taken by urine on its way out of the male's body. Those who did not include an arrow to show the pathway from the ureter (connected to the kidney) to the bladder were only able to gain one of the two marks allotted to this question.

In Part (c) (i), candidates were asked to explain how one of the structures shown in the diagram of the human male reproductive system could be manipulated to achieve permanent sterility in males. This was well done as most candidates explained that doing a vasectomy would involve cutting the sperm duct and would prevent sperm made in the testes getting into semen so eggs could not be fertilized during sexual intercourse. A good candidate response was:

*To achieve permanent sterility a vasectomy can be carried out in which the vas deferens can be cut preventing sperm from exiting through the urethra.*

Part (c) (ii) required that candidates explain how tubal ligation results in sterility in females. Most candidates were able to state that this involved tying off/cutting the oviducts but only a few candidates correctly explained that this would prevent mature eggs being fertilized in the oviducts leading to female sterility. Several candidates had the misconception that ovulation would not occur. A good candidate response was:

*In tubal ligation the oviduct is cut and tied. Ovulation still occurs but sperm and egg cannot meet so fertilization cannot occur.*

Candidates were asked to explain two ways in which the method of reproduction by which new potato shoots are produced from the buds/eyes of a potato tuber was different from reproduction in humans in Part (d). Most candidates were awarded full marks for correctly stating at least two ways in which asexual reproduction in potatoes differs from sexual reproduction in humans. A candidate response that was awarded full marks was:

*This method of reproduction is asexual, only one parent is needed to reproduce whereas in human needs male and female for sexual reproduction. The offspring of this type of reproduction in those plants are genetically identical to parent (no variation) whereas human offspring genetically vary.*

#### Question 4

This question tested candidates' knowledge of pathogenic diseases, insect vectors and immunity. The mean was 6 as was the mode.

In Part (a), candidates were asked to name two ways by which the human body prevents itself from becoming infected. Few candidates were awarded the full two marks for their responses. The expected responses included *the skin, blood clots, tears to protect the eyes, cilia and mucus in the respiratory passageways and hydrochloric acid in the stomach*. A good candidate response was:

*The skin prevents the body from disease by acting as a wall of protection from viruses and bacteria. Also the hairs and mucus in the nose trap bacteria from entering the body.*

In Part (b) (i), candidates were required to describe the life cycle of a named insect vector then explain how knowledge of the life cycle of the named vector could be used to prevent transmission of a named pathogenic disease in response to Part (b) (ii). Most candidates were able to gain at least three of the six marks allotted for naming the insect vector and describing at least two stages of the insect's life cycle accurately and in the correct sequence. The words *pupa* and *mosquito* were frequently misspelled. Some candidates lost marks because they did not put the stages in correct sequence or name a suitable pathogenic disease in Part (b) (ii). Two good candidates' responses awarded full marks for Parts (b) (i) and (ii) were:

*The life cycle of a mosquito consists of the egg, larva, pupa and adult. Knowing the life cycle of a mosquito can help prevent the spread of malaria because each stage of the life cycle needs certain conditions to survive. One example is that eggs are laid in water catchments. Eliminating water catchments can decrease the number of eggs laid in the area, therefore decreasing the mosquito population.*

Candidates who wrote on vectors of disease such as rats, snakes were not awarded marks.

In Part (c), candidates were told that a student was about to travel to a country where yellow fever is rampant and asked to explain how a vaccine could provide the student with active acquired immunity against the disease. Several candidates gained only two of the four marks allotted to this part of the question for stating that antibodies are produced to destroy the pathogen which causes yellow fever and if the student is affected again, antibodies would be produced more quickly to prevent the person getting the disease again. Only a few candidates gave a full explanation about what the vaccine contains and how it works. A good candidate response was:

*When the student is vaccinated, a weakened version of the yellow fever virus is injected into their system. The body reacts to the disease, its white blood cells begin producing antibodies against the virus. The antibodies kill the virus and the body reproduces the antibodies and stores them. Anytime the virus shows up again, the body will have the antibodies for the virus and will be able to kill the virus quickly, making the student immune.*

Candidates who stated that the ‘body’ rather than *lymphocytes* produced antibodies did not get marks. Part (c) (ii) asked candidates to discuss why a vaccine that provides passive acquired immunity would not be suitable for the student. Only a few candidates understood the term passive acquired immunity and recognized that the student would be given antibodies. A good candidate response was:

*A vaccine that provides passive acquired immunity is not suitable since this vaccine contains readymade antibodies that are injected to help the body fight disease and some of these antibodies are destroyed when they kill the virus. The major drawback of this is that memory lymphocytes were not created for that virus since the person was injected with antibodies and the person does not actively acquire immunity if infected again so it would take it weeks for memory lymphocytes to be created to fight and destroy the virus.*

### Question 5

This question examined candidates’ understanding of selected ecological terms as well as the carbon cycle. It also tested candidates’ ability to apply their knowledge about mangrove ecosystems to justify constructing houses on mangrove land. The mean and mode were 8 out of 15 marks.

Part (a) asked candidates to define three ecological terms: *population*, *physical* (abiotic) factors and *habitat*, making reference to the mangrove ecosystem. Several candidates were able to gain two of the six marks allotted to this section for giving the correct definition of the term *population* as *the members of the same species living within a particular area* and *habitat* as *the place where an organism lives*. They were also expected to cite an example from the mangrove ecosystem to be awarded the full two marks for each definition and relevant example given. An example of a candidate’s response that was awarded full marks was:

*A population is a group of organisms all of the same species, living in the same habitat with the ability to interbreed and produce fertile offspring. E.g. a population of tree snakes living in the mangrove.*

*Abiotic factors are all physical non-living factors that influence the activities of many organisms e.g. light intensity and salinity of water. Abiotic factors in the mangrove swamp would be water-logged brackish soil and the temperature.*

*A habitat is the natural home of an organism where it lives and reproduces. The habitat in the mangrove ecosystem would be the mangrove vegetation (or trees) and the swamp area.*

Several candidates lost marks because they did not know the difference between the terms *population* and *community*.

In Part (b), candidates were asked to propose one argument to support and two arguments against supporting the plans of some investors who want to remove the mangrove swamp and develop the land for housing. Most candidates gave reasonable arguments for and against the proposal. An example of a good candidate response was:

*One argument to support this plan is that the development of these houses would provide a place for people to live who don’t already own a house. The development project would provide houses for people in a country where space is limited. Two arguments against the housing development project are 1) The construction of houses would destroy the mangrove*



*plants which are essential in the holding of the soil together in the area where they are located and 2) the housing development programme would displace numerous populations of organisms living in the swamps and they would now have to find a new habitat to live in and most of the organisms may be killed during construction of the houses.*

Part (c) asked candidates to explain the effect on the carbon cycle of cutting and burning large areas of mangrove trees across the Caribbean. Most candidates were able to give good responses that were awarded at least two of the three marks allotted to this part of the question. Candidates' responses that were awarded marks explained that *cutting and burning large areas of mangrove trees would lead to increased amounts of carbon dioxide in the air since these trees would have used the carbon dioxide in the process of photosynthesis to make their food.* A candidate's response that was awarded full marks was:

*Cutting down of the mangrove vegetation (trees) would increase the level of carbon dioxide gas in the atmosphere since there would not be any of these trees to take in carbon dioxide for photosynthesis. Burning large areas of mangrove trees also causes a build up of carbon dioxide gas in the atmosphere since burning (combustion) releases carbon dioxide. When trees are cut down, they are decomposed by bacteria and fungi that take the complex carbohydrates, lipids and proteins and incorporate them in their bodies and when they respire they would release carbon back into the atmosphere as well.*

A common misconception among several candidates was that global warming was caused by depletion of the ozone layer.

#### Question 6

This question examined candidates' knowledge of the endocrine functions of the pancreas and pituitary gland, properties of enzymes and the homeostatic function of insulin, glucagon and the anti-diuretic hormone (ADH). The mean was 6 and the mode 2.

Candidates were required to sketch an outline of the human body and show the location of the pancreas and pituitary gland on the sketch in Part (a) (i). Most candidates were able to gain at least one mark for showing the correct position of the pancreas but many did not know where the pituitary gland was. Those candidates who were able to answer Part (a) (i) correctly were usually able to name hormones secreted from each of the glands in responding to Part (a) (ii) and give two factors, such as *pH* and *temperature*, that could affect enzyme activity in Part (a) (iii).

In Part (b), candidates were asked to explain how pancreatic hormones worked together with the liver to regulate blood sugar levels. This was usually well done by candidates. A good response awarded full marks was:

*When the blood sugar level in the body is too low or too high, the body is made aware of this by a feedback mechanism which restores the blood sugar level back to its normal levels. When the blood sugar level is too high, the pancreas secretes the hormone insulin into the blood stream and this causes the cells of the liver to convert excess glucose into glycogen to be stored by the liver. When the blood sugar level is too low, the pancreas the hormone glucagon, which will cause the glycogen stored in the liver to be broken down into glucose and restored to the blood stream to be used by the body.*

In Part (c), candidates were asked to describe how a pituitary gland hormone would work to prevent complete dehydration if they were lost on a desert island for two days. Many candidates seemed not to be familiar with the role of the antidiuretic hormone (ADH) in osmoregulation. A good candidate response was:

*When the body is dehydrates or lacks sufficient water for body processes, the hypothalamus in the brain detects this and it stimulates the pituitary gland to secrete the hormone ADH or the antidiuretic hormone. More of this hormone will be secreted so that more water is reabsorbed*

*from the urine being formed in the kidney by acting on the kidney tubule. So when more water is absorbed from the urine, the water is returned to the body for necessary processes and less water will be excreted from the body as urine and the urine will be less in quantity and not as dilute.*

### **Paper 032 – Alternative to School Based Assessment (SBA)**

This paper consisted of three questions designed to examine the experimental skills of private candidates. Candidates' ability to conduct ecological investigations, plan and design an experiment or investigation to determine the dry mass of seedlings, analyse and interpret data, as well as make drawings of specimens were assessed. Performance on this paper was similar to that of 2012. Although this paper is done by private candidates, preparation must include exposure to practical investigations.

#### Question 1

This question tested candidates' practical skills in relation to carrying out ecological investigations, analysing and interpreting data and classifying living organisms based on visible features. Candidates did not perform well on this question as the mean was 10 out of 27 marks and the mode was 9.

In Part (a), candidates were asked to describe how a line transect could be used to investigate the changing distribution of organisms two miles inland from a river bank on either side of a river. Candidates were awarded marks for stating that they would *peg a rope/string/tape measure at a point on the river bank and extend it in a straight line 2 miles inland at right angles to the river; then observe/record all the species of organisms seen at regular intervals.* A candidate's response that was awarded full marks was:

*One pole is placed on the river bank and another is placed 2 miles inland from the river. A long string is then tied to the poles and a measurement and count of the various organisms at different distances between the poles are collected and recorded.*

Candidates were given a table with results obtained from quadrat throws from an investigation of the distribution of three different plant species found within 100 m on either side of the river bank in Part (b). They were then asked to show how they would calculate the species density of each of the three plant species in Part (b) (i). Candidates who did not show how they arrived at their results were not awarded full marks if they had the correct result. Only candidates who showed their calculations as instructed were able to gain full marks. Several candidates only found the sum of all the organisms in each quadrat throw and were not awarded any marks. They were awarded marks for dividing the total number of each plant species by 10 and getting the correct result for the species density (number of plant species per m<sup>2</sup>).

In Part (b) (ii), candidates were asked to suggest two reasons why the number of ferns counted on the third quadrat throw was so low. Candidates were usually able to give good suggestions and were awarded marks if they mentioned that the quadrat was thrown randomly into an area where ferns were not suitably adapted to survive or the ferns in that particular area were removed by humans or eaten by herbivores. They were then asked to predict which of the plant species would be furthest from the river bank in Part (b) (iii). Candidates were expected to use their knowledge of xerophytes such as the cactus species to predict that these plants would be found furthest away since they are adapted to survive in dry areas. Candidates who analysed the data and predicted that the flowering shrubs were furthest away because they had the lowest species density also were able to gain full marks.

In Part (c), candidates were given six drawings of organisms found in the area of the forest and asked to name one visible feature other than wings to classify the organisms into two groups in Part (c) (i) and then describe how they would investigate the distribution of the flying organisms in Part (c) (ii) and state one precaution that should be taken when using the procedure described in Part (c) (iii). Several candidates were able to gain at least one of the five marks allotted to Part (c) (i) for naming a visible feature such as antennae, number of legs or segmented bodies. Only a few candidates were able to name the two groups for classifying the organism appropriately. Expected groupings were: *antennae present vs antennae absent*; 3

*pairs of legs vs 4 pairs of legs; 2 segments vs 3 segments.* Very few candidates were awarded marks for their procedure in Part (c) (ii). Candidates were expected to describe that they would use a *sweep net/jars to capture the animals that fly, then count the number of the organism caught and record the numbers.* Some candidates described the *capture-recapture* method and were awarded full marks. Only a few candidates were able to state suitable precautions such as *mark or tag the animals so they are not counted more than once or hold the wings/body with care so as not to kill them.*

Part (d) was the easiest part of the question as most candidates were able to score at least two of the three marks for putting the ferns at the base of the pyramid, or in some cases the beginning of a food chain, and the small bird at the top. Only candidates who illustrated the feeding relationships by drawing a pyramid similar to any of those shown below were able to gain full marks.

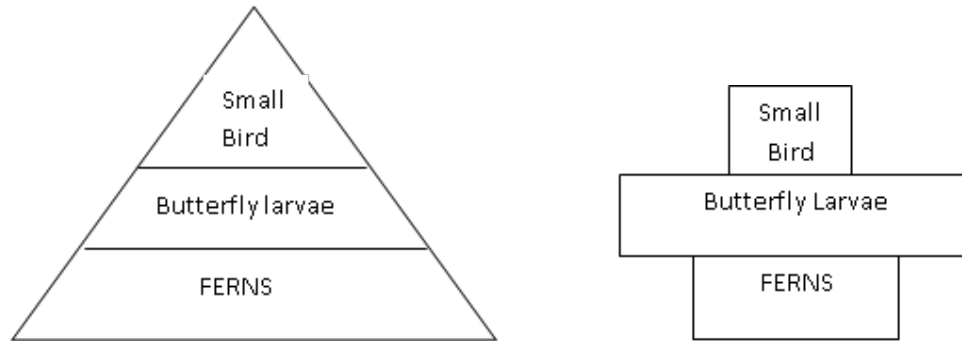

Most candidates were able to gain full marks for Part (e) which required that candidates give a reason why biologists should or should not encourage developers to build houses in that particular area. Candidates were expected to indicate whether they were in support of building the houses or not then give their reason. Reasons for supporting the building of houses that were awarded marks included *population is increasing and people need adequate housing or that the area did not seem to be densely populated with a wide variety of species.* While arguments proposed for not supporting housing construction were *reduce biodiversity by destroying the plant and animal species; destruction of trees which are a habitat for some organism and encourage rainfall; destruction of the ecosystem by disrupting important feeding relationships and development close to the river would encourage pollution.*

## Question 2

This question assessed candidates ability to plan and design investigations, calculate averages, analyse and interpret data as well as their knowledge of the growth and development of dicotyledon seedlings. The question was poorly done as indicated by a mean of 9 out of 23 marks and a mode of 3.

In Part (a), candidates were asked to suggest why the seeds taken from the same dicotyledonous plant did not have exactly the same weight. Very few candidates were able to explain that this was due to variations in the water and nutrient content of the seeds, genetic variations among the seeds that occurred during meiosis or even human error during the weighing of the seeds. The most common answer was difference in size. The term *dicotyledonous plant* was interpreted to mean 'plant species' by some students.

Part (b) (i) required that candidates describe how they would investigate the dry mass of a batch of the seedlings by listing the apparatus they would use and the procedure. This was also well done by very few candidates. The list of apparatus should include a scale and an oven or similar apparatus for drying the seedlings. The procedure should include the drying of the seedlings in the oven for a set time then weighing the dried seedlings at regular intervals until a constant mass is obtained. In Part (b) (ii), candidates were asked to suggest a suitable aim relating to treating one batch of the seedlings with varying amounts of organic fertilizer. An example of a well stated aim was:

*To investigate the effect of organic fertilizer on the growth rate of a batch of seedlings*

Part (b) (ii) required that candidates identify which batch of seedlings would be considered the control in this investigation and those who stated that batch A would be the control because they have been exposed to all the conditions except fertilizer gained marks.

Part (c) required that candidates show how they would calculate the average dry mass of three seedlings taken from each of the batches and record their results in a table provided. Several candidates only found the sum of the masses and were not awarded any marks as they could only earn marks if they divided the sum by 3 and recorded the correct answer. In Part (c) (ii), candidates were required to plot a graph of the data in table 3. Several candidates were only able to score three of the five marks allotted because the axes were not correctly labelled, the scale used was inappropriate and some points were not plotted correctly. Candidates who included a key, labelled both axes correctly, used an appropriate scale and plotted all the points correctly were able to gain the full five marks. Candidates who gained at least three marks in Part (c) (ii) were usually able to gain the two marks for Part (c) (iii) which required that candidates determine the average dry mass of the seedlings on Day 8 using the graph they plotted. Candidates were expected to identify Day 8 on the x-axis and find the corresponding dry mass at the point where each line crossed day 8. Batch A was  $4.6 \pm 0.2$  mg and Batch B was  $5.8 \pm 0.2$ mg. Part (c) (iv) was not well done as many candidates described the shape of the graph instead of explaining the difference in the shape of the graphs. The difference in shape is due to the fact that organic fertilizer supplies nutrients to the seedlings in B so they grow faster.

### Question 3

This question tested candidates' drawing and measurement skills as well as their knowledge of the respiratory surface of bony fish. The question was very poorly done with a mean and mode of 2 out of 10 marks.

In Part (a) (i), candidates were given a drawing of the head of a bony fish with its gills exposed and asked to make a labelled drawing of the gills in the space provided. Two marks were allocated for clarity, representation and labels. An average of two marks was gained for this section as most candidates were able to correctly identify the gill from the diagram and attempted to draw without shading. This was very poorly done by most candidates who had difficulty drawing an accurate, proportionate drawing with clean continuous lines and many were not familiar with the names of the gill structures. Part (a) (ii) was also poorly done as many candidates appeared to have little or no knowledge about how to calculate the magnification of the drawing. Candidates were expected to measure the longest section of the drawing and specimen and divide the size of the drawing by the size of the specimen to get the correct magnification.

In Part (b), a few candidates gained one of the two marks for identifying *thin gill filaments* but the large surface area was rarely mentioned.

### **Paper 03 – School-Based Assessment (SBA)**

Performance on the school-based assessment was commendable at some centres. Favourable trends that continue to be observed include: *good syllabus coverage (that is, a minimum of nine syllabus topics covered) by most of the centres that were moderated; an increase in the number of centres where both quantitative and qualitative fieldwork were done; general compliance with syllabus guidelines regarding the number of times practical skills were assessed.* This suggests that most teachers recognize the value of providing sufficient opportunity for students to develop and master all the specific practical skills. However, while the skill of Observation, Recording, Reporting (ORR) was generally well done, Drawing (Dr), Analysis and Interpretation (AI), and Planning and Designing (PD) continue to present candidates with the most difficulty.

While the level of organization and presentation of books submitted from most centres was good, there were still some centres that submitted books without the requisite information. The CSEC Biology syllabus (page 44) provides guidelines for candidates' preparation of practical books for submission. Some important requirements often not met include: a Table of Contents which provides a list of the aims of practical activities, page numbers, dates, as well as *clear* and *specific* indications of the activities used for the SBA together with the skills being assessed for each activity. In addition, the marks awarded for each practical activity must be placed alongside the practical and not simply listed at the front or back of the books.

The lack of comments in the lab books, especially for skills performed poorly, suggests that students are not being given adequate feedback on their progress throughout the period of study. Frequently, only ticks are observed, along with the final score awarded for the skills but students appear unaware of their strengths or deficiencies.

The moderation exercise was often hampered by poor mark schemes. Teachers are being reminded that mark schemes must be legible and preferably bound together instead of on loose sheets of paper. There must be a *clear* and *direct* relationship between the marks awarded to the appropriate activities in the practical books and the marks on the tally sheets. It should also be noted that no more than two skills should be assessed in a single practical activity. New teachers in particular should consult pages 38–44 of the Biology syllabus for guidance in preparing and presenting mark schemes.

The following is a list of criteria which teachers should follow in marking SBA activities.

- Marks should be awarded for each skill separately. It is noted that in some cases, marks were given for the each skill then tallied to give a composite score. This is unacceptable.
- Marks awarded to students should be a fair indication of the quality of their work. Too many students received high marks for work that fell short of the CXC standard. This was particularly noticeable for Planning and Designing, Analysis and Interpretation, and Drawing. When the CXC standard is not observed there is great disparity between the teacher's score and that of the moderator. This circumstance is usually *disadvantageous* to students.
- Marks submitted on the moderation sheet should reflect students' marks in each of the samples. Consistency of marking and submission of marks relate to the reliability of the process and thus acceptability of marks submitted.
- Teachers are once again reminded that body fluids such as saliva, blood and urine are not to be used for practical work. These can be sources of infection and may have serious legal implications should a student become infected while conducting practical work. Plant materials must be removed from books before they are submitted to CXC, since these are also potential agents of infection when moved from place to place.

The examining committee would also like to recommend that there be greater cooperation among teachers of similar subjects at the same centre and mentoring of new teachers, to ensure that standards are consistently maintained.

A review of previous schools reports will provide additional suggestions for developing practical skills. Further suggestions are reiterated in this report and each teacher is alerted to the specific strengths and weaknesses displayed by their students in the Moderation Feedback Report sent to schools after moderation. The Moderation Feedback Report, which is sent to each centre, provides constructive and useful information relevant to the particular teacher(s). This report offers specific recommendations and is intended to assist teachers in the planning, conducting and assessing of practical work — in the laboratory and field. Improvement of students' practical skills will have a direct influence on the overall performance of candidates in the Biology examination, since certain questions, notably Question 1 on Paper 02, and where applicable questions on Paper 032, are based on knowledge and application of these practical skills.

### Specific Comments on the Assessment of Skills

The following information is to assist teachers, especially new ones in interpreting the information given on the CXC Moderation Feedback Report. *It should first be noted, however, that the number of times a skill is assessed is considered sufficient if assessed a minimum of four times, except for the Planning and Designing skill which is assessed twice.*

#### Observation, Recording, Reporting (ORR)

This skill appears to be the one best mastered at most centres. Generally candidates presented reports in which the method was clearly described with a logical sequence of activities. Usually past tense was correctly used as required. Careful attention should be given to grammar, quality of expression and detailed description since science students need to appreciate the importance of clarity in explaining their results. During the conduct of the lab exercises, whenever possible, students should also be encouraged to repeat procedures to improve the reliability of their results.

The tables and graphs were usually clear and provided adequate details which allowed for a clear description and discussion of the experiment. The examining committee recommends that teachers provide more activities where students construct their own tables and graphs using their results. This will allow them the opportunity to develop these skills.

#### Guidelines for Drawing Tables and Graphs

##### Tables

The title should be written in *capital letters*, and appropriate column headings used. (See example below.)

TABLE 1: BREATHING RATE AFTER EXERCISE	
Time (mins)	Number of Breaths
1	15
3	12
5	9

##### Graphs

The title should be *written below the graph and underlined*; axes should be labelled with *units* stated and a *key* should be given if necessary.

If calculations are required, all necessary calculations should be presented neatly and in an organized fashion. Units should also be included where necessary.

When drawings are used in reporting observations, they should meet standard SBA drawing criteria.

##### Drawing (Dr)

Most teachers selected drawing exercises from those indicated in the syllabus. These included bones, flowers, seeds, fruits and storage organs.

While a range of drawing exercises can be given to students, there are some that should not be selected. Since most schools in the region only provide light microscopes, it is not a good practice to assign students microscope drawings of cells and then give full marks to a reproduction of an electron microscope diagram showing structures which would be impossible to see with a light microscope. Marking drawings of dissections is also problematic since structures in a dissected specimen are usually difficult to discern and students resort to textbook drawings for presentation in their lab books.

Many of the mark schemes used by teachers did not reflect the CSEC standard for drawing and this resulted in a large discrepancy between the marks awarded for drawings by teachers and moderators.

An example of an appropriate mark scheme submitted by one centre is given below.

*Activity: To examine different storage organs and make annotated drawings*

*Criteria for Assessment of Drawing*

*Clarity – clear continuous of even thickness – 1*

*Drawings large in size – 1*

*Accuracy – faithful representation of specimen/correct proportions – 2*

*Label lines drawn with ruler and pencil touching structure, no arrowheads, not crossing, writing in script – 2*

*Title must be written below each drawing and underlined with appropriate storage organ mentioned – 1*

*At least of the drawings annotated – 2*

*Presence of magnification – 1*

*Total = 10 marks*

Table 1 is a list of Do's and 'Don'ts' applicable to SBA biological drawings at the CSEC level.

**TABLE 1: DO'S AND DON'TS OF BIOLOGICAL DRAWINGS**

Do's	Don't s
<ul style="list-style-type: none"> <li>• Use pencils for all drawing activities – drawing, label lines, labels.</li> <li>• Use drawings of actual biological specimen (not diagrams, models or textbook drawings); ensure that there are drawings of flowers, fruits, seeds and bones for assessment.</li> <li>• Ensure that the size of drawings are at least half page.</li> <li>• As far as possible, have label lines and labels positioned to the right of drawings.</li> <li>• Ensure that all label lines end at the same vertical plane.</li> <li>• Ensure that label lines are drawn parallel to the top/ bottom of the page.</li> <li>• Ensure label lines end on part being made.</li> <li>• In the title, use the word '<i>drawing</i>' and not '<i>diagram</i>'.</li> <li>• Position title under the drawing and indicate the actual name of the specimen (for example, cervical vertebrae of a goat, mango leaf, hibiscus flower) <i>and</i> the view drawn.</li> <li>• Underline the title.</li> <li>• Include the magnification and state where appropriate, actual length and width of specimen as well as place 'x' in front of the magnification.</li> <li>• Write magnification to one decimal place.</li> <li>• Use a key to explain symbols where appropriate, for example, stippling/cross hatching.</li> </ul>	<ul style="list-style-type: none"> <li>• No arrow heads</li> <li>• No crossing of label lines</li> <li>• No dots or dashes</li> <li>• No joining of letters or words for labels or titles.</li> </ul>

The examining committee also encourages teachers to ensure that standard drawing criteria are applied whenever drawings are required in lab activities, especially when reporting observations and/or illustrating biological processes, for example, germination, regardless of whether DR skills are to be assessed. This should help students appreciate the importance of the skill.

Teachers should also ensure that students draw on plain paper and then neatly insert drawings into lab books, if the books are not designed with plain sheets of paper for drawing. Distinguishing features and label lines are oftentimes unclear when drawings are done on ruled sheets of paper.



### Analysis and Interpretation (AI)

This skill is still problematic for the majority of candidates. Many students simply recorded the relevant theory/background information but made no attempt to use this information to provide an explanation for their results. Most neglected to state a logical conclusion or suggest limitations which may have affected their experiments/investigations.

While questions given by the teacher may be used to stimulate discussion, the students' reports should not consist only of answers to these questions. Such questions must guide students to provide the required background information, give explanations for the results, draw conclusions and show an awareness of possible limitations. The information provided in this way should then be written up as a paragraph of continuous prose as is normally done for the discussion/conclusion. In many cases, candidates seem to have learnt a formula for writing up the discussion but showed no real understanding of how to interpret their own results. As a learning strategy, teachers may ask students to orally explain the results to obtain a clearer view of their understanding and to help them develop their analytical skills.

The marking criteria used by some teachers did not include *limitations*. It was sometimes observed that precautions/control/sources of error were often accepted as limitations by the teacher.

The use of controls should also be emphasized in discussions as they are a point of comparison for the experimental set-up in which a particular variable has been omitted. This comparison should be included in the discussion as it is the key to drawing the conclusion. Conclusions should relate directly to the aim of the investigation. Students should also be reminded to discuss at least one limitation of the investigation. It is important for them to recognize that the conditions present in a school laboratory are rarely ideal.

The processes involved in demonstrating the AI skill are reiterated here.

- Background information may be written in the *discussion*, or *introduction* section.
- Background information for the experiment must relate to the theory.
- The discussion should be an analysis or interpretation of the recorded experimental results. It must not simply answer posed questions for AI:
  - Questions may be used to guide students but answers must be written in paragraph format (without the questions, or written comprehension style).
  - Questions should not to be included in the lab report.
- The conclusion must be based on the aim. (It is a brief answer to the aim.)
- Limitation(s) should be included among the AI marking criteria as very important to lab(s).
- Identifying source(s) of error and precaution(s) are necessary as is knowing that these are both different from each other and from limitation(s).
- All components of AI (background knowledge, explanation of results, limitations and conclusion) should be included in the mark scheme for the skill.

The examining committee is again reminding teachers that food tests *on their own* are not appropriate for assessing AI. Simple investigations can be designed in which food tests are used. For example, students can be given unknown mixtures and asked to find out which food would be most suitable for an infant. Food tests can also be used to determine the presence of a particular food before and after digestion by an enzyme. These types of exercises will allow students to develop the necessary skills. Knowledge of the food tests and the nutritional requirements can then provide the background information on which they will base their conclusions.

Most of the mark schemes submitted this year for marking the AI skill did not meet the CSEC standard. This resulted in large discrepancies between the teachers' and moderators' marks.

An example of an appropriate mark scheme submitted by one centre is given below.

*Aim: To investigate transport in plants using celery stalks.*

*Skill marked AI:*

*Background information – 3*

*Explanation/interpretations of results – 4*

*Conclusions based on observations/data related to aim – 2*

*Limitations – 1*

*Total = 10 marks*

### Manipulation and Measurement (MM)

Most of the exercises scanned for this skill were appropriately selected from those activities which asked the students to use simple laboratory equipment. However, not all samples seen were accompanied by relevant mark schemes. Teachers should indicate which criteria were met in students' lab books and also provide written feedback.

As has been the trend in previous years, this skill continues to be the one that most candidates appear to have achieved mastery of, based on the observation that most are awarded full marks. However, evidence such as the generally poor performance on the practical aspects of Question 1 on Paper 02 of the final examination, suggests that the SBA marks for the MM skill may not be the result of rigorous marking. Also, if virtually all students in a class gain full marks on an activity, this suggests that the task may not be demanding enough or the criteria not detailed enough to allow the necessary discrimination between different levels of performance.

The examining committee recommends that teachers expose students to as wide a range of apparatus and their use in collecting data as is possible. This would aid in the development of students' manipulation skills and allow for a more fair assessment of their competence in MM.

### Planning and Design (PD)

Performance on this skill has shown some improvement relative to former years, and teachers should be commended for demonstrating more creativity in the types of observations/problem statements provided to students on which to base their hypotheses and design their experiments. The examining committee continues to emphasize the importance of using examples from students' local environment as this will help them better appreciate how they can apply their biological knowledge and practical skills to solve problems they frequently encounter. Teachers are reminded that it is *inappropriate* to have students copy procedures from textbooks and reproduce them verbatim for assessment of PD skills.

An example of a good planning and design activity submitted by one centre is given below.

*Assignment*

*It was observed that when cows were given a certain brand of feed, they produced a larger quantity of milk than those that feed on other brands. Plan and design an experiment to investigate the above observations.*

*Suggested Teacher's Mark Scheme*

*Hypothesis acceptable and based on observations – 2*

*Aim relevant to hypothesis – 1*

*Materials and apparatus appropriate – 1*

*Method feasible/attempt to control conditions – 1*

*Control included – 1*

*Repetition/large sample used – 1*

*Expected results stated – 1*

*Limitations noted – 1*

*Format suitable for planning and design activity – 1*

*Total = 10 marks*

**CARIBBEAN EXAMINATIONS COUNCIL**

**REPORT ON CANDIDATES' WORK IN THE  
CARIBBEAN SECONDARY EDUCATION CERTIFICATE<sup>®</sup> EXAMINATION**

**JANUARY 2014**

**BIOLOGY  
GENERAL PROFICIENCY EXAMINATION**

## GENERAL COMMENTS

The January 2014 sitting of the CXC Biology examination consisted of three papers: Paper 01 — Multiple Choice; Paper 02 — Structured/Extended Essays and Paper 032 — Alternative to School-Based Assessment (SBA).

Candidate performance on this examination was slightly better than in the previous sitting of the January examination. The examining committee continues to hope that candidates and teachers will continue to pay careful attention to the comments and suggestions being offered in this and previous reports to ensure that improvements are sustained.

The committee would like to reiterate once again that greater attention needs to be paid to the following list of recommendations prepared to further enhance the future performance of candidates based on observations of their performance on this sitting of the examination.

- Practice reading questions carefully and planning responses so that answers are organized in a logical and cohesive manner.
- Review and become familiar with the glossary of terms at the back of the syllabus. This will aid the understanding of key words such as *annotate*, *describe* and *explain* when reading the questions.
- Be guided by the mark allocation and quantitative descriptors within the text of the question as far as possible. This will help interpretation of what is being asked and minimize/prevent the giving of irrelevant information in responses.
- Use biological jargon as required in expressing biological phenomena as this increases the accuracy of descriptions and reduces errors caused by oversimplification.

More emphasis should be placed on developing practical skills in the teaching of biology.

Planning and designing and drawing skills continued to be problematic for candidates and negatively impacted their performance in responding to questions on Paper 032 — Alternative to the SBA. Too many candidates seemed unfamiliar with basic laboratory equipment and material and even the simplest biological/scientific methods. Candidates demonstrated particular weakness in identifying precautions, formulating hypotheses, designing suitable procedures for carrying out investigations and writing conclusions.

## DETAILED COMMENTS

### Paper 01 – Multiple Choice

Paper 01 consisted of 60 multiple-choice items. Performance on this paper was quite similar to that of 2013. Some of the topics that were most problematic for candidates were:

- The nitrogen cycle
- Deficiency diseases
- Transport in plants
- Plant storage organs
- Excretion in plants
- Sensitivity in animals
- Reflex arc

### Paper 02 – Structured and Extended Essays

Paper 02 consisted of six compulsory questions. Questions 1 to 3 were in the structured response format and Questions 4 to 6 in the extended essay format. Most candidates were able to score marks across the range for almost all questions.

#### Question 1

Syllabus Objectives: B1.2, 2.1, 2.2, 3.1, 3.2, 3.4

This question tested candidates' practical knowledge of respiration in living organisms and to a lesser extent photosynthesis. Although candidates were able to access marks across most of the range (0–23), their performance was generally poor. The mean mark awarded was 8.

Candidates were given an incomplete diagram of apparatus used to test the hypothesis that both green plants and small animals produce carbon dioxide during aerobic respiration.

In Part (a) (i), candidates were required to identify the materials that should be placed in each jar to investigate carbon dioxide production during aerobic respiration. In setting up this experiment, it is important to note the function of each jar: Jar I contains soda lime or other compound which will remove carbon dioxide from the incoming air, since this is the gas produced during aerobic respiration and which will be tested for in Jar IV containing the lime water. Jar II also contains limewater to test that the air which enters Jar III containing the test organism (either small animal or green plant) is free of carbon dioxide. Once this is understood, candidates would not try to test

both organisms simultaneously either by putting one in Jar II, or by putting both plant and animal in Jar III.

The more able candidates accurately stated that *Jar I should have soda lime, Jars II and IV should have lime water and a small plant or animal should be placed in Jar III*. Very few candidates stated that *Jar I should contain soda lime to remove or absorb the carbon dioxide in the air prior to exposing it to the named organism in Jar III*. A few candidates also misinterpreted *both* in the stem of the question to mean that both a plant and an animal organism should be placed in Jar III. Most candidates were able to state for Part (a) (ii), that *in Jar IV, lime water which is clear becomes milky white*. Those who stated that carbon dioxide would be observed did not get marks since the gas cannot be observed directly.

In Part (b), candidates were told that in order to test the hypothesis using plants only, a piece of black cloth is used to modify the apparatus. Then in Part (b) (i), they were asked to describe how the apparatus in the diagram given is modified to test the hypothesis that plants produce carbon dioxide during aerobic respiration. Several candidates responded correctly by stating that *a small plant would be placed in Jar III and then the jar would be covered with a black cloth*. They were also able to explain in Part (b) (ii) that *the black cloth in the experiment prevents the plant from photosynthesizing* and that *some of the carbon dioxide produced during respiration is used up in the photosynthesis*. However, the responses of some candidates to both Parts (b) (i) and (ii) indicated that the notion that green plants do not respire during the day when photosynthesis is proceeding, still persists. This may be clarified if teachers point out that only the chlorophyll containing parts of the plant are photosynthesizing and that the non-photosynthesizing parts require energy to carry out their functions (for example: storage, cell division and growth). The CO<sub>2</sub> produced from respiration is masked since the plants are using it up during photosynthesis. This information also helps students to understand the CO<sub>2</sub> compensation point later on. In this experiment, the plant was kept in the dark to prevent the carbon dioxide produced in respiration from being used up in photosynthesis.

Some candidates had difficulty with Part (b) (iii) where they were asked to suggest two precautions related to the experiment. They were expected to give answers including *sterilizing jars to ensure no microorganisms are in it; ensuring that the glass tubing was inserted below the level of the limewater; or ensuring that live organisms were used*.

Part (c) (i) asked candidates to write a chemical equation to summarize aerobic respiration. Most candidates were able to gain at least one mark for either stating correct reactants (oxygen and glucose) or products (carbon dioxide, water and ATP/energy). Candidates who gave the equation for photosynthesis did not get marks for their response.

In Part (c) (ii), most candidates were able to correctly explain that *aerobic respiration was important to living organisms to get energy from food to perform activities such as growth, locomotion and reproduction*. Some candidates had the misconception that aerobic respiration is the same as breathing.

Part (d) was also well done as most candidates were familiar with examples of at least two end products of anaerobic respiration, namely *carbon dioxide, ethanol or small amounts of energy/ATP*. *Lactic acid* was also awarded marks as there are some anaerobes that produce lactic acid as a respiratory product.

Several candidates successfully completed the table in Part (e) to distinguish the process of photosynthesis from respiration. It was observed that a few candidates incorrectly identified the organelle in the case of photosynthesis as chlorophyll instead of naming the chloroplast. Some candidates were unable to gain marks because they could not name at least two raw materials or two final products of each process.

## Question 2

Syllabus Objectives: B7.11; C 3.2, 3.3, 3.4

This question tested candidates' knowledge of the structure of mammalian skin and genetic terms as well as their ability to use genetic diagrams to explain inheritance of albinism. Candidates' performance on this question was also poor even though some of them were able to gain the maximum 15 marks. The mean score was 6.

In Part (a), candidates were given a diagram showing a vertical section through the mammalian skin. Part (a) (i) required that they identify the structures labelled A to D. Several candidates were unable to identify all four structures, especially the epidermis (A), which some simply called the outer layer and were awarded no marks. Structure D, the sweat gland, was sometimes incorrectly called a network of blood vessels. It is important to note that marks were not awarded if the labels were spelt incorrectly.

Part (a) (ii) was well known and most candidates were able to identify that the largest quantity of melanin should be in the malpighian layer or basal layer of the epidermis as it helps to protect the skin from damage by UV light.

In Part (b), candidates were told that albinism is characterized by a lack of melanin in the skin and that the genotype of someone with an albino phenotype is aa. They were then required in Part (b) (i) to define the terms *allele*, *genotype* and *phenotype*. This posed the most difficulty for candidates and several of them did not attempt a response. Candidates were expected to know



that the term *allele* refers to *alternative forms of a gene which normally occurs in pairs*. Some candidates simply gave symbols such as A and a to represent alleles without giving an explanation. These candidates were awarded no marks. Most candidates defined genotype correctly as a pair of alleles; and the phenotype was explained as the physical expression of the genotype.

An example of a good candidate response to this part of the question is given below.

*Alleles are alternative forms of the same gene with contrasting characters found in the same relative positions on homologous chromosomes.*

*Genotype is the genetic make-up in terms of alleles for a certain characteristic.*

*Phenotype is the visible effect of a genotype.*

In Part (b) (iii), candidates were required to use a genetic diagram to explain how two non-albino parents could produce an albino offspring. Candidates were expected to draw a genetic diagram similar to the one below.

Parent genotype:	<b>Aa</b>	X	<b>Aa</b>											
Gametes:	<b>A</b>	<b>a</b>	X	<b>A</b>	<b>a</b>									
Fertilization:	<table border="1" style="border-collapse: collapse; margin: auto;"> <tr> <td style="width: 30px; height: 30px;"></td> <td style="width: 30px; text-align: center;"><b>A</b></td> <td style="width: 30px; text-align: center;"><b>A</b></td> </tr> <tr> <td style="text-align: center;"><b>A</b></td> <td style="text-align: center;"><b>AA</b></td> <td style="text-align: center;"><b>Aa</b></td> </tr> <tr> <td style="text-align: center;"><b>a</b></td> <td style="text-align: center;"><b>Aa</b></td> <td style="text-align: center;"><b>aa</b></td> </tr> </table>						<b>A</b>	<b>A</b>	<b>A</b>	<b>AA</b>	<b>Aa</b>	<b>a</b>	<b>Aa</b>	<b>aa</b>
	<b>A</b>	<b>A</b>												
<b>A</b>	<b>AA</b>	<b>Aa</b>												
<b>a</b>	<b>Aa</b>	<b>aa</b>												
Expected genotype:	1AA	2Aa	1aa											
Expected phenotype:	3 Non-albino to 1 albino offspring													

Candidates should be reminded that when asked to draw genetic diagrams, their response must include the allele in each gamete from each parent, as well as an illustration consisting of either a Punnett square or a line diagram, showing how the gametes from each parent could pair up during fertilization. Some candidates simply stated the expected genotype, ratio and/or phenotype of the offspring without correctly showing the pairing of the gametes.

Part (b) (iii) required that candidates suggest the genotypes of parents who would never have albino children. This was generally well done as candidates were able to correctly state AA X AA or AA X Aa.

### Question 3

Syllabus Objectives: B 9.6, 9.7, 9.8, 9.11

This question examined candidates' ability to relate the structure of flowers to their method of pollination, as well as their knowledge of the sequence of events which take place after pollination that give rise to fruit formation, and methods of seed dispersal. Performance on this question was very poor. Candidates were able to score across the full range (0–15), but the mode was 0 and the mean was 6.

Candidates were given two diagrams of two flowers labelled X and Y taken from two different plants. Part (a) (i) asked them to indicate on each flower, the parts that give rise to the male gametes; and in Part (a) (ii), they were required to suggest the agent of pollination for each flower. These were generally well done as most candidates appeared to be familiar with the position of the anther and common features of insect and wind-pollinated flowers. Many candidates ignored the instruction to label the structures (anthers) M and labelled all the parts of the flower.

Part (b) (iii) required that candidates suggest two features of each flower that makes them suited for the type of pollinating agent suggested in Part (b) (ii). This was sometimes well answered as candidates correctly named *large petals, the presence of both an anther and a stigma* or *nectar at the base* as features suited for pollination by an insect in the case of Flower X; and *long feathery stigma, long filaments hanging out of flowers* or *having small inconspicuous petals/no petals* in the case of Flower Y. A common misconception observed in several responses to Part (b) (iii) was that the position of the anthers in relation to the stigma was an important feature for insect pollination. This feature is significant for self- vs. cross-pollination.

In Part (d), candidates were asked to describe the sequence of events which takes place after pollination to give rise to a fruit. Although most candidates were familiar with some of the events, many had some difficulty describing how the pollen was able to travel to the ovary and the events leading up to fertilization were sometimes not clearly described. An example of a good candidate response that was awarded full marks was:

*The pollen grain forms a pollen tube in which two male nuclei travel to the ovary. They pass through the micropyle and fertilize the ovum. These ova develop into seeds and the ovary into a fruit.*

In Part (c), candidates were given a diagram of a fruit formed from one of the flowers and asked to suggest two methods of dispersal of the seeds found inside the fruit. Most candidates were awarded full marks for this section as they were able to state animals or explosive or mechanical methods.

#### Question 4

Syllabus Objectives: B1.1, 1.2, 1.5, 1.6

This question tested candidates' knowledge of the structure of plant and animal cells, functions of organelles unique to plant cells, as well as the behaviour of each of these cells in dilute solutions. It also examined their understanding of the importance of osmosis and diffusion in living systems. Candidate performance on this question was very good. There was general familiarity with the topics and candidates were able to gain marks across the full range (0–15). The mean was 9 marks.

In Part (a) (i), candidates were asked to make labelled drawings to show the structures of a generalized plant and a generalized animal cell. Most candidates were able to produce representative drawings of both cells but some candidates were not awarded marks because labels were spelt incorrectly. Many candidates did not indicate whether the cell drawn was an animal or plant cell. It was also observed that several candidates drew the organelles disproportionately. The nucleus is usually the largest of the organelles but sometimes it was drawn as the smallest organelle and the large permanent vacuole of the plant cell was sometimes drawn very small relative to the other organelles. It was also observed that the drawings were generally untidy and in many cases the rules governing biological drawings were not followed. Candidates should be reminded that labels should be on one side of the drawing and label lines should be drawn with a ruler. Drawing lines should be clean continuous lines as well.

In Part (a) (ii), candidates were asked to name two organelles which are unique to plant cells and suggest the significance of these organelles to the survival of the plant. A few candidates were not awarded marks for identifying chlorophyll as an organelle instead of chloroplasts.

In Part (b) (i), candidates were asked to explain the effect on each type of cell if each was placed in a container of distilled water for 15 minutes. They were then required to explain, for Part (b) (ii), how the process responsible for the results would differ from that by which gases move in and out of leaf cells. A common misconception was that water cannot enter plant cells because of the cell wall.

For Part (b) (ii), candidates correctly made reference to Part (b) (i), even though the question cited Part (c). Good responses were usually given as most candidates were able to explain that

the process involved in the movement of water into each type of cell was osmosis and the absence of a cell wall would result in animal cells bursting while the plant cell would get turgid. A good candidate response for both sections was:

*Osmosis would occur through the cell membranes of both the animal and plant cell. The plant cell would become turgid and not burst because of the support from the cell wall. The animal cell may burst since the water content inside the cell would be too much for the membrane to hold.*

*The process involved in the results in Part (b) (i) is called osmosis which involves the movement of water molecules. The process through which gases move in and out of leaf cells is called diffusion — the movement of particles from a region of high concentration to a region of low concentration until they are evenly distributed.*

*Osmosis involves water molecules while diffusion is associated with particles.*

It is being suggested that teachers create crossword puzzles, word sleuths, cryptograms (online puzzle makers) and use them to help students develop their capacity to spell correctly, as well as give students opportunities to practice drawing and labelling parts of living organisms. Practical use of 3D cell models would also assist students preparing to sit these examinations to become more familiar with the cell organelles.

### Question 5

Syllabus Objectives: A2.6, 2.7, 4.1; B2.11; E 5.1, 5.3

This question tested candidates' knowledge of aspects of the nitrogen cycle and the consequences of nitrogen deficiency in plants as well the effect of nitrate fertilizers on aquatic organisms and solutions to the problem. Most candidates were able to gain marks across most of the range (0–15) but overall performance on this question was generally poor. The mean for this question was 5 and the mode was 4.

In Part (a) (i), candidates were required to draw a simplified labelled diagram of the nitrogen cycle to show three processes that involve bacteria and one process that does not involve bacteria. Most candidates' responses suggested that they were familiar with most of the stages involved in the cycle but they did not identify that bacteria are involved in nitrogen fixation in the soil/root nodules of leguminous plants, nitrification, decomposition of organic waste such as urea and de-nitrification. A few candidates correctly identified that the role of lightning in nitrogen fixation does not require bacteria.

Quite a few candidates confused the nitrogen cycle with the carbon cycle and listed photosynthesis and respiration as processes which do not require bacteria.

The consequences of nitrogen deficiency required in Part (a) (ii) were widely known. An example of a succinct candidate response to this question is given below.

*Nitrogen is needed to make proteins in plants. Plants that are nitrogen deficient will be protein deficient also, hence they will have poor, stunted growth and yellow spindly leaves.*

Part (b) (i) asked candidates to explain how excess nitrate fertilizer may be responsible for the overgrowth of algae and death of the aquatic organisms. Many candidates found this part difficult as it appeared they were unfamiliar with eutrophication. Candidates were expected to explain that

*nitrate fertilizers are washed into the rivers and aquatic organisms such as algae are able to use the nitrogen from the fertilizers to make protein for growth and reproduction. This allows them to multiply and use up some of the oxygen from the water. Since they mostly live on the surface of the water, they also block sunlight from reaching the other organisms, in particular the plants with leaves below the surface of the water, so they are unable to photosynthesize and die.*

Part (b) (iii) required candidates to discuss three ways in which the problem could be remedied. This was generally well done. An example of a candidate response that was awarded full marks is:

*One solution is that the farmers utilize another type of fertilizer that does not contribute to eutrophication, such as an organic one. This will prevent any more excessive growth of algae in the river.*

*Another solution is that algae could be completely eradicated from the river. Therefore, there can be no overgrowth if there are no algae.*

*Another solution would be to educate farmers about using fertilizers when they have planted near rivers. If farmers are educated about the best places to plant their crops, they would make wiser decisions therefore reducing the problem of eutrophication.*

## Question 6

Syllabus Objectives: B2.6, B2.10

This question examined candidates' knowledge of the internal structure of a tooth and the functions of the different parts. It also tested their ability to relate the structure and role of the different types of teeth to consumption of a varied diet. Mechanical digestion of food was also tested. Candidate performance on this question was satisfactory, with a mean of approximately 8 and a mode of 8. Candidates earned scores in the range 0–15 out of a maximum score of 15.

In Part (a), candidates were asked to use an annotated diagram in describing the functions of the enamel, dentine and pulp of a named tooth. Poor drawing quality and untidy annotations were a feature of most responses to Part (a) and marks were not awarded for incorrectly spelt labels. Several candidates were familiar with the fact that the enamel is the hard outer covering which allows physical breakdown of food, and that it protects the softer inner layers of the tooth. However, many did not know that the dentine is the layer under the enamel and it contains cytoplasm which provides nutrients such as calcium to the tooth. The pulp cavity was poorly represented in many cases.

Part (b) was very well done and most candidates were able to relate the roles of the different types of teeth in the mouth to having a varied diet and further stated how this is beneficial to a mammal. Candidates were able to explain that having a varied diet allows the individual to get a wide range of nutrients from eating a range of foods that also helps to ensure that the diet is balanced. They also said that persons are less likely to suffer from deficiency diseases and get a range of components (for example, fibre) to support their health.

In Part (c), candidates were told of an 80-year-old man who lost his teeth and were asked to explain how this would affect his ability to digest food. Candidates were also required to suggest how he could obtain the essential nutrients that his body requires. This was also generally well answered by candidates. An example of a good response was:

*Not having teeth means that the man cannot chew properly. Enzymes work best with high surface area and the fact that the food is not being cut up into smaller bits means that digestion by enzymes cannot work at its best so foods and nutrients would be wasted. Large food particles also mean a harder time swallowing and defecating. The old man could go to his doctor and get nutritional supplements that are easily absorbed in his body or crush or blend his food before eating it. He could also drink liquid meal supplements.*

### **Paper 032 – Alternative to the School-Based Assessment (SBA)**

This paper assessed the range of practical skills required of biology students and consisted of three compulsory questions. Although there was significant improvement in the overall performance during this sitting of the examination, many candidates continue to display weak practical skills especially in aspects of planning and designing (including the assembling of apparatus), describing realistic methods of experiments and producing representative drawings. These observations reinforce the need for teachers to provide opportunities for students to develop their practical skills. Once again the examining committee reiterates that candidates *must be exposed to actual experimenting and investigating scientific phenomena, discussions, explanations and rationalizing of procedures and outcomes* so that they become capable of developing and manipulating experiments and experimental data on their own.

#### Question 1

This question examined candidates' practical skills in planning and designing investigations involving the enzyme amylase breaking down starch at different temperatures. They were also required to demonstrate that they knew how to test for the presence of starch and reducing sugar, as well as represent data using a suitably constructed table. Candidates' performance on this question was satisfactory and they were able to gain marks across the full range (0–25). The mode was 9 and the mean was 10.

In Part (a), candidates were told that after 15 minutes a sample of amylase–starch mixture taken from each of five test tubes, each kept at five different temperatures were tested for starch. Part (a) (i) required candidates to list the apparatus, describe the procedure and state the expected result if starch is present. Several candidates were unable to list suitable apparatus such as droppers/pipettes to take each sample and place it onto a white tile or in another test tube for testing, test tube holders or stop watches. Many candidates also had difficulty describing that a dropper would have been used to first take out the sample mixture from one test tube then place a drop on white tile; then another dropper would be used to drop iodine on the sample mixture. Most candidates were able to state that the expected result would be a blue-black colour if starch is present.

Most candidates were able to score at least one mark for Part (a) (ii) which required that candidates suggest two precautions that must be taken to ensure accuracy of the results. Correct responses given included *using equal amounts of samples for the test*, as well as *ensuring that each of the mixtures is timed accurately for 15 minutes before the sample is removed*. Other

responses candidates were expected to suggest were *ensuring that the white tile/test tube containing the sample to be tested was clean*; and *using a clean dropper to obtain the samples*.

In Part (b), candidates were told that another sample of the amylase–starch mixture was taken from each of the test tubes after 20 minutes and tested for the presence of reducing sugar. The colour change results observed in each sample tested were presented in a table. Part (b) (i) asked candidates to explain how a reducing sugar could be formed in this experiment. Most candidates were able to get at least one mark for stating that the enzyme amylase breaks down starch to maltose. An additional mark was awarded if candidates also stated that maltose is a reducing sugar.

In response to Part (b) (ii), several candidates were able to suggest that a suitable aim for the experiment would be *to investigate the effect of temperature on amylase activity*. However, many were unable to gain full marks for fully explaining why the samples kept at 0, 60 and 80 °C showed a blue colour when tested for a reducing sugar as required in Part (b) (iii). Several candidates were not awarded full marks because they did not explain that *at 0 °C the enzyme was inactive due to a lack of kinetic energy*. Some also wrongly said that the enzyme was denatured at 0 °C. Candidates were expected to explain that *amylase is inactive at 0 °C so starch was not broken down to maltose/reducing sugar. The optimum temperature of amylase is below 40 °C so the enzyme is denatured at or above this temperature preventing it from breaking down starch to maltose*. Candidates were also awarded marks if they mentioned that *Benedict's reagent that is used to test for reducing sugar is blue and if there is no reducing sugar, it remains blue*.

In Part (b) (iv), most candidates were able to score at least one of the two marks for suggesting two possible sources of error in the experiment. Candidates were awarded marks for responses such as *heat would be lost to the surroundings, therefore, sample not kept exactly at a constant temperature*; *the volume of each sample not equal*; *poor mixing of the sample mixtures to be tested*; or *equal time not given to each sample before testing*.

In Part (c), candidates were told that a similar experiment was carried out to investigate the pH at which amylase optimally converts substrates to products and they were given a graph showing the results of that experiment. In Part (c) (i), candidates were asked to construct a table to represent the data shown in the graph. This was not well done by many candidates. Candidates were expected to draw a table using a ruler with the independent variable (pH) placed in the first column (or row if a vertical table was used) and the rate of reaction with the units (mg/unit time) stated in the second column. Most candidates were able to gain marks for accurately reading and recording most of the rate of reaction values at each pH from the graph. Some candidates were unable to score full marks because they did not include a title. Candidates were generally able to gain full marks for writing a conclusion for this investigation as required in Part (c) (ii). Based on the aim stated in the stimulus material, the conclusion was that amylase works optimally in



neutral (pH 7) conditions. Candidates who mentioned that amylase is denatured by low or high pH were not awarded marks as this conclusion was not related to the aim of the investigation.

## Question 2

This question was based on apparatus set up to investigate the effect of light intensity on the rate of photosynthesis in an aquatic plant. Candidate performance on this question was fair. The mean score was approximately 6 out of a total of 18, and candidates were able to score marks across the range 0–18.

In Part (a) (i), candidates were required to write a hypothesis that could be tested using the apparatus shown in the diagram. Some candidates stated the hypothesis in the form of an aim or an expected observation and could not be awarded marks. Another common error was stating that ‘light intensity *affects* the rate of photosynthesis’. Such a statement would not allow the experimenter to state whether the results observed either support or do not support the hypothesis since both an increase or a decrease in the rate would support the hypothesis. Candidates are being reminded that a hypothesis is an explanation based on a particular observation about how things work or why something happens. A suitable hypothesis would have been *an increase in light intensity results in an increase in the rate of photosynthesis*.

Part (a) (ii) required that candidates describe how the apparatus could be manipulated to test their hypothesis. Candidates’ descriptions were expected to include that light intensity was varied by varying the distance of the light source from the photosynthesizing plant; the oxygen given out during the process was collected by the downward displacement of water in the measuring cylinder and the amount of oxygen produced at each light intensity was measured by counting the number of oxygen bubbles produced or measuring the volume of air in the cylinder after a fixed period of time. Many candidates had difficulty describing a suitable control for the investigation as asked in Part (a) (iii). Any of the following responses were accepted as a control:

*Remove/turn off/cover the light source.*

*Maintain the light source at a fixed distance.*

*Remove the plant/replace with a dead plant.*

In Part (b) (i), candidates were asked to identify the gas labelled in the measuring cylinder. This was answered correctly by most candidates as oxygen. Some candidates were however unable to gain full marks in Part (b) (ii) which required them to describe a confirmatory test for oxygen. Most candidates were able to describe that *a glowing splint was inserted into the measuring cylinder after quickly removing it from over the inverted funnel; and that the glowing splint rekindles in the presence of oxygen*. A mark was also awarded if candidates stated that the splint was lit then extinguished leaving only a glow which is inserted in the cylinder.

In Part (c), candidates were given drawings of two leaves taken from two aquatic plants found in a river. In Part (c) (i), candidates were asked to use graph paper to determine the surface area of each leaf. Several candidates were unable to determine the surface area using graph paper which involves counting the number of squares (each of which is 1 cm<sup>2</sup>). In some cases, candidates were not awarded full marks because they did not record the units of measurement. Based on the information given in the question, it was reasonable to assume that candidates, in responding to Part (c) (ii), would have chosen Leaf B as the one found growing at 5 metres below the surface of water since the larger surface area would allow for maximum light exposure and gas exchange as well as more chlorophyll for greater photosynthesis. Candidates were also given credit for justifying their choice of Leaf A by arguing that plants growing at that depth in that environment would have narrow long leaves to reach the surface and less chlorophyll content since light is needed for synthesis of chlorophyll.

### Question 3

This question tested candidates' ability to make a labelled drawing of an artery and calculate the magnification of the drawing. They were also required to explain how the artery is adapted to carry out its function, then represent hypertension data in a table using a suitable graph as well as suggest reasons for the differences in trends between males and females. Candidate performance on this question was satisfactory. The mean was approximately 8 out of 17 and the mode was 4.

In Part (a), candidates were given a drawing of the external view of a blood vessel that transports blood away from the left side of the heart of a small mammal. In Part (a) (i), they were required to produce a fully labelled drawing of the blood vessel as it would be viewed in transverse section, that is, cut along the line indicated in the diagram. Poor drawing skills prevented several candidates from being awarded the five marks allotted. Very few drawings were done with the clean, continuous lines expected and although the lumen of the blood vessel in the original drawing was small, many candidates did not represent the small diameter in proportion to the thickness of the diameter of the wall accurately. Only a few candidates were able to label their drawings correctly. Candidates are being reminded to use a ruler to draw label lines and to place labels on the same side of the drawing as much as possible. Most candidates were able to calculate the magnification of their drawing as asked in Part (a) (ii) using the formula:

$$\text{Magnification} = \frac{\text{Size of drawing}}{\text{Size of original drawing}}$$

Part (a) (iii), which asked candidates to explain how one feature shown in the drawing makes the blood vessel suited for its function, was also generally well done. The thick (elastic) walls of the blood vessel enables it to withstand the high pressure of blood being pumped from the heart; and

the small lumen helps to maintain a high pressure required to push blood to the other parts of the body. Candidates who mentioned that the thick elastic walls are able to stretch and recoil moving blood away from the heart and to the rest of the body also gained marks.

In Part (b), candidates were given data about the number of hypertension related deaths reported among males and females in some Caribbean countries from 1985 to 2000. In Part (b) (i), they were asked to draw a suitable graph to represent the data on a grid provided. Several candidates were unable to score the five marks allotted either because they used an inappropriate scale, did not label the axes correctly or did not use an appropriate key to distinguish male from female data. Most candidates were able to suggest three credible reasons to explain the difference in the number of hypertension related deaths among males and females. Reasonable explanations that gained marks were that:

*Women were not exercising as much as men.*

*Women were consuming excess salt in their diet compared to men.*

*More women were overweight/obese than men.*

*More women were stressed than men.*

These responses related to the risk factors associated with the development of hypertension which candidates should have learned.

Private candidates may also find it useful to review previous comments on performance on Paper 032 from past examinations as well as the SBA component of past May/June sittings of the examination for additional comments and recommendations relating to practical skills.

**C A R I B B E A N E X A M I N A T I O N S C O U N C I L**

**REPORT ON CANDIDATES' WORK IN THE  
CARIBBEAN SECONDARY EDUCATION CERTIFICATE® EXAMINATION**

**MAY/JUNE 2014**

**BIOLOGY  
GENERAL PROFICIENCY EXAMINATION**

**Copyright© 2014 Caribbean Examinations Council  
St Michael, Barbados  
All rights reserved.**

## GENERAL COMMENTS

The June 2014 examination in Biology at the General Proficiency level was the 46th sitting of this subject conducted by CXC and the first to be marked electronically by a team of competent professionals internationally and across the Caribbean. Biology continues to be offered at both the January and June sittings of the examinations. The biology examination is one of the more popular of the single sciences offered by the CXC at the CSEC level and assessed the performance of approximately 18,000 candidates this year. The examination comprises four papers: Paper 01 – Multiple Choice; Paper 02 – Structured/Extended Essay paper; Paper 03, the School Based Assessment (SBA); and Paper 032 Alternative to the SBA (offered only to private candidates).

The overall performance of candidates this year was similar to that of last year's with candidates scoring across the full range of marks in almost every question. Several candidates demonstrated above average knowledge of fundamental biological concepts and principles relating to feeding relationships, the heart and the carbon cycle. Topics such as genetics, sexual reproduction in flowering plants, accommodation by the human eye as well as practical based questions which require that candidates plan and design experiments or make drawings, still present major challenges for many candidates.

Some improvement was seen in candidates' test-taking techniques as more candidates were able to give concise responses in the spaces provided without repeating the question and it was evident from the quality of many responses that candidates are being encouraged and guided by teachers in practicing how to interpret and answer questions clearly and to the point. This suggests that some attention is being paid to the recommendations being given in the reports by the Biology examining team over the years. To ensure that these improvements are sustained however, attention must be paid to the comments reiterated below in preparing the candidates.

- Teachers should try as much as possible to dedicate adequate time to the teaching and formative assessment of all specific objectives (S.O.) covered by the syllabus. It appeared that several candidates were not familiar with important topics in Section C of the syllabus and consequently were unable to respond to the genetics and natural selection questions.
- Biological jargon should be used where appropriate and the spelling of biological terms must be correct in order to be awarded marks.
- Teachers should ensure that candidates are familiar with the meaning of terms listed in the glossary of the biology syllabus, especially those frequently used in writing questions such as 'annotate', 'compare', 'describe', 'design' and 'explain'.
- A constructivist approach to the teaching and preparation of biology students will enhance their ability to explain their ideas, clarify content and get them more engaged in problem solving activities. It was evident that some candidates were learning content by rote as these candidates were usually unable to adequately respond to questions that required that they apply their knowledge.
- Practical activities should be used to support the teaching of theoretical content and not treated as a separate activity. Practical skills such as drawing, analysis and interpretation, and planning and design in particular, should be developed as part of regular class proceedings and not just given attention in a 'laboratory' type setting. The consistently poor performance in practical skills observed in the review of SBA and inability to score full marks for most practical -based questions suggest that candidates were not given sufficient opportunity to develop their practical skills.

## DETAILED COMMENTS

### PAPER 01 – Multiple Choice

Paper 01 consisted of 60 multiple choice items. Performance on this paper was satisfactory and quite similar to that of last year's.

Some of the topics that were *most* problematic for candidates were:

- oxygen debt
- transport in plants
- the structures of the skin involved in temperature regulation
- immunity

### PAPER 02 – Structured and Extended Essays

Paper 02 consisted of six questions three of which were in the structured response format and three in the extended essay format. This paper tested all profile skill areas identified in the Biology syllabus. All questions were compulsory. Candidates' performance on this paper was similar to that on the June 2013 paper. Candidates were able to gain marks across the range of marks allotted for all questions.

## SECTION A

### Question 1

This question examined some important practical skills including candidates' ability to construct tables to record data, label a drawing of a gill and analyse graphical data. It also tested candidates' knowledge and understanding of feeding relationships within a marine ecosystem (S.O. A1.1, 2.4, 2.5, E3.1). Most candidates attempted this question and a few were able to gain full marks but performance was below expectation. The mean was approximately 14 out of 25 marks.

Candidates were given drawings of eight different types of fish collected from a marine ecosystem in Part (a). Part (i) required that they construct a table to classify the fishes into groups using two visible features other than size. Several candidates were able to use a ruler to construct a neat table with appropriate row/column headings relating to visible features which allowed for accurately placing the fishes into groups. A few candidates also, as required, included a title for the table. Some candidates were not awarded full marks because they failed to describe two visible features and only named one feature being present or absent. Visible features that were correctly used for grouping the organisms included: Scales – present or absent; Shape of the tail – curved inwards or outwards; Spikes/Spines – present or absent; Number of dorsal fins – one or two. Candidates were also expected to use the numbers I to VIII to identify which fish was to be placed in each group. This was sometimes not done and those candidates were unable to earn the mark for classifying the fishes into groups.

Candidates were asked to annotate a drawing of the gill of a fish to illustrate two characteristics that make the gill suitable for gaseous exchange in Part (a) (ii). Very few candidates were able to annotate the lamellae as being thin or having a large surface area as required. Some candidates could not be awarded marks even though they wrote the correct annotations because they incorrectly positioned the label lines by the gill bar. A few candidates had the misconception that the gills are able to carry out inhalation and exhalation under water. Only those whose annotation indicated that the diffusion of gases takes place quickly through the thin walls and across the large surface area of the lamellae were awarded marks.

Most candidates were able to correctly state two reasons why gaseous exchange is important in living organisms in response to Part (a) (iii). Responses that were awarded marks included the following:

- *To obtain oxygen for respiration/energy production to take place;*
- *To excrete or remove carbon dioxide which can be poisonous to the organisms;*
- *Homeostasis - plants require carbon dioxide from the atmosphere for photosynthesis/make their food;*

were awarded marks.

Part (b) was well done by most candidates. A diagram of a food web in the marine ecosystem was given and several candidates were able to correctly identify sea grass, phytoplankton and corals with zooxanthellae as the producers in the food web in responding to part (b) (i). They were generally also able to state two characteristics of producers in a food web in responding to part (ii). Characteristics of producers named by most candidates were that the producers: have the ability to make their own food, contain chloroplast/chlorophyll, trap sunlight for photosynthesis, are found at the beginning of a food chain/web and/or make food by chemosynthesis. A common misconception was that all producers are plants.

In Part (iii), candidates were required to identify the type of feeding relationship described between a coral and zooxanthellae and give the reason for the type identified. Although most candidates were able to correctly identify the feeding relationship as mutualism since both organisms benefit from the association, some candidates incorrectly said commensalism. It was also observed that the term ‘mutualism’ was frequently misspelt.

Candidates were given a table showing data of the estimated number of parrot fish and a predatory fish over a three year period in Part (c). In Part (c) (i) candidates were asked to represent the data on a suitable graph. Only a few candidates were awarded full marks for the graphs plotted. Marks could not be awarded if: an inappropriate scale was used in constructing the axes; both axes were not completely labelled, or a title or a key was not provided.

Candidates were asked in Part (c) (ii) to suggest an explanation for the differences in the shape of the graphs. Marks were awarded if candidates explained that the predatory fish did not have predators to feed on them or that the parrot fish were being fed on by the predatory fish. Marks were not awarded for describing the trends in the numbers of fish observed.

Part (c) (iii) asked them to name two features that the predatory fish may have that allow it to carry out its role as a predator. Most candidates were able to state features such as having sharp teeth, strong jaws, fast swimmers, very good eye sight or producing poisonous secretions to immobilize prey.

In Part (c) (iv), candidates were usually able to suggest that the size of the population of prey of the predatory fish would decline drastically or there would be an increase in the population of the organisms consumed by the parrot fish/prey as the likely consequences of the uncontrolled increase in the population size of the predatory fish. Other responses that were accepted mentioned that there would be a reduction in biodiversity or there would be increased competition for food, space or mates. A common misconception was that the species of prey would go extinct.

## Question 2

This question tested candidates’ knowledge of the structure and function of select parts of the human circulatory system as well as the transport system of plants (S.O. B4.3, 4.5, 4.6, 4.7, 4.9; D1.2). Candidate performance on this question was good. While candidates were able to access marks across the full range of the question, their performance showed a mean of 7 out of 15.

Candidates were given a diagram of an external view of the human heart in Part (a) and asked to identify the structures labelled A, B and C in Part (i). This was well done by most candidates. The terms vena cava, aorta and ventricle were often misspelt.

In Part (a) (ii), they were asked to explain how the function of the heart may be affected by a blockage of a blood vessel labelled X on the diagram. A few candidates were able to identify that the blood vessel labelled X was the coronary artery that supplies the heart muscles with blood so if it was blocked, the heart would stop pumping blood and the individual would have a cardiac arrest/heart attack.

In Part (b), candidates were given a diagram of blood vessels labelled A and B, used to transport fluids around the body of a mammal. Arrows were used in the diagram to show the direction of flow of the blood. In Part (i) most candidates were able to correctly identify blood vessel B as the vein. Part (ii) however asked them to identify one structure visible in the diagram which helps a vein to carry out its function. Part (iii) then required them to explain how that structure allows the vein to fulfill its function. Candidate responses to these parts of the question were usually awarded full marks as most candidates were able to identify the valve and knew that the valve helps the blood which is flowing at a lower pressure to flow in one direction by preventing backflow.

In Part (b) (iv), candidates were told that diets high in saturated fats may lead to the formation of plaques in blood vessels. They were then asked to explain how such deposits may lead to hypertension. Most candidates got at least one of the two marks for mentioning that the formation of plaque would cause the diameter of the blood vessels to get smaller. Only a few candidates also mentioned that this would result in an increase in the pressure on blood flowing through the arteries or cause the heart to have to pump harder increasing the pressure to keep blood flowing to the organs and tissues throughout the body.

In Part (c), candidates were given a diagram of the transport vessels in a flowering plant and asked to identify the vessels at positions labelled P and Q. Several candidates were able to correctly identify P as xylem and Q and phloem but some candidates were unable to spell the terms correctly.

Part (d) required candidates to explain why plants do not need an organ like a heart in their transport system and outline a mechanism by which plants move fluids through their transport vessels. Only a few candidates were able to suggest that plants do not need a heart because they have a lower metabolic rate or that substances do not need to be delivered to plant tissues at a fast rate. A common misconception was that plants are all small organisms so they do not need a heart. Candidates also had a difficulty describing a mechanism by which plants move fluids. They were expected to mention that plants have a pumping mechanism to move water across the root into the xylem or that they have a pulling mechanism, transpiration pull, as a result of evaporation from leaves. A few also correctly mentioned cohesive or adhesive forces, or capillarity helping water to move up the xylem against gravity.

### Question 3

This question tested candidates' knowledge of the structure and function of the kidney tubule (nephron), osmoregulation and diabetes (S.O. B5.4, 5.5; D1.2). Candidates' performance on this question was poor with few obtaining full marks. The mean was 6 out of a possible 15 marks.

In Part (a), candidates were provided with a diagram of a nephron found in a human kidney then asked to identify the structures labelled A, B and C and describe the process that takes place in each of the structures in Part (i). This was done correctly by many candidates but the terms Bowman's capsule and Loop of Henlé were often spelt incorrectly.

Part (ii) required candidates to name the hormone secreted by the pituitary gland when there is not enough water in body cells. Most candidates were able to name the antidiuretic hormone or ADH.

In Part (iii), candidates were asked to explain why the composition of urine produced by the nephron of someone who drank a lot of water would differ from that of someone who had no water to drink for over 24 hours. Most candidates were awarded at least two marks for stating that the urine of the person who drank a lot of water would be dilute or pale in colour while that of the person who drank no water would be concentrated or yellow due to the kidney reabsorbing some of the water. Very few candidates also mentioned that the changes in blood concentration of water is detected by the hypothalamus which causes the pituitary gland to stop secreting antidiuretic hormone (ADH) when blood concentration falls/when a lot of water is consumed and this causes the kidneys to reabsorb only a little water; while the pituitary of the one



who drank no water would secrete more ADH to cause the kidney to reabsorb more water if none was consumed.

In Part (b), candidates were given a table showing the amount of select substances (glucose, protein, urea, sodium chloride and water) found in the urine of a healthy person and a diabetic. Part (i) required them to explain why there is glucose in the urine of the diabetic person assuming that the kidneys are functioning properly. Many candidates were awarded one mark for mentioning that the blood glucose levels are higher than the levels the kidney is normally able to reabsorb but only a few were able to explain that this was because diabetics are unable to use or store the excess glucose with the help of insulin because insulin is not being produced or the cells are not responding to the insulin. A common misconception was that diabetics have higher than normal blood sugar because they are unable to break down glucose. Students should be reminded that glucose is the end product of digestion so it is broken down inside the cells to produce energy during respiration. In the case of diabetics, they are unable to absorb the glucose into the cells to use it up during respiration or store excess amounts as glycogen in the muscles and liver, due to a lack of insulin or because their cells are unable to respond to the insulin produced.

In Part (ii), they were asked to describe two ways of managing diabetes mellitus. Most candidates correctly mentioned reducing sugar consumption, regular exercise or using medications to regulate blood sugar such as injecting insulin. A common misconception was that diabetes can be managed by drinking a lot of water. Students should be taught that this may increase the frequency of urination but not help in the management of diabetes.

## SECTION B

### Question 4

This question examined candidates' knowledge of the carbon cycle (S.O. A4.1; E4.2, 5.1, 5.2, 5.3). Performance on this question was good as illustrated by a mean of 7 out of 15 marks.

Part (a) required candidates to use a diagram to outline three processes which return carbon to the atmosphere and one which removes it from the atmosphere. They were also instructed to include the form in which carbon is found in the atmosphere. This was generally well done as most candidates were able to illustrate that plants take in carbon dioxide and use it for photosynthesis, then release it back to the atmosphere following respiration. Respiration by animals and decomposers as well as the burning or combustion of fossil fuels to release carbon back to the atmosphere were also shown.

In Part (b) candidates were asked to describe the impact of cutting down or burning large areas of forest on the recycling of carbon. This was not very well done as most candidates misinterpreted the question and spoke about the impact on global warming, climate change and even the ozone layer. They were expected to explain that cutting down trees may contribute to an increase in the amount of carbon dioxide in the atmosphere to be recycled because they would not carry out photosynthesis to use it up and burning would result in carbon compounds also being released into the atmosphere. Fewer trees may also lead to a reduction in the number of organisms in that particular area because the trees provide food and a habitat for them; so less respiration would be carried out which results in less carbon dioxide production and release into the atmosphere.

Many candidates were able to give good responses to Part (c) which required that candidates suggest three ways in which humans can make changes in their day to day activities to reduce the amount of carbon in the atmosphere. An example of a candidates' response that was awarded full marks was:

*Three ways in which humans can make changes in their day to day activities to reduce the amount of carbon in the atmosphere are: carpooling so that there are less vehicles to produce carbon monoxide; dispose of garbage properly or otherwise recycle rather than burning it so that burning is kept down to a minimum; and walk or use bicycles when going short distances to minimize the burning of fossil fuels.*

A common misconception was that aerosol sprays and chlorofluorocarbon compounds (CFCs) release carbon dioxide into the atmosphere.

Question 5

This question tested candidates' knowledge of genetic terms, continuous and discontinuous variation and the theory of natural selection as well as their ability to use genetic diagrams to illustrate the pattern of inheritance of albinism (S.O. C2.6, 3.2, 3.3, 4.4). The performance on the question was poor with the mean mark obtained being 5 out of 15 marks.

Part (a) of this question examined candidates' ability to define the terms: genotype, phenotype, recessive and dominant. This was very poorly done as most candidates seemed unfamiliar with the terms. The genotype can be described as the alleles or genes that an individual possesses while the phenotype is the physical expression of those genes/alleles. Recessive is the term used to describe the allele that this not expressed in the phenotype of the individual who is heterozygous. Dominant is the term used to describe the allele expressed in the heterozygous state. Some misconceptions that were repeatedly observed in several candidates' responses to this part of the question were that dominant genes are strong or superior while recessive alleles are weak.

In Part (b) (i), candidates were asked to give two examples of continuous variation. Most candidates correctly identified height, weight and length as characteristics which show continuous variation but Part (b) (ii) which required candidates to use appropriate symbols to draw a genetics diagram to show the genotypes of the parents and expected phenotypes of the offspring of a man with normal pigmentation and an albino woman was poorly done. Many candidates were awarded at least two marks for using appropriate symbols to represent the alleles for normal pigmentation or albinism and correctly identifying either the mother's or father's genotype. Very few were able to correctly illustrate how the alleles from each parent would pair up during fertilization using a punnett square. Some candidates did not state the phenotype of the offspring produced or used sex linked alleles and were not awarded any marks. A candidate response that was awarded full marks was:

*Let A represent Normal pigmentation*

*Let a represent Albino*

<i>Parent phenotype</i>	<i>Father with normal pigmentation</i>	<i>X</i>	<i>Albino mother</i>						
<i>Parent genotype</i>	<i>Aa</i>	<i>X</i>	<i>aa</i>						
<i>Gametes</i>	<i>A      a</i>	<i>X</i>	<i>a              a</i>						
<i>Fertilisation</i>	<table style="margin-left: auto; margin-right: auto; border-collapse: collapse;"> <tr> <td style="padding: 0 10px;"><i>a</i></td> <td style="border: 1px solid black; padding: 5px; text-align: center;"><i>Aa</i></td> <td style="border: 1px solid black; padding: 5px; text-align: center;"><i>aa</i></td> </tr> <tr> <td style="padding: 0 10px;"><i>a</i></td> <td style="border: 1px solid black; padding: 5px; text-align: center;"><i>Aa</i></td> <td style="border: 1px solid black; padding: 5px; text-align: center;"><i>aa</i></td> </tr> </table>	<i>a</i>	<i>Aa</i>	<i>aa</i>	<i>a</i>	<i>Aa</i>	<i>aa</i>		
<i>a</i>	<i>Aa</i>	<i>aa</i>							
<i>a</i>	<i>Aa</i>	<i>aa</i>							
<i>Offspring genotype</i>	<i>Aa              aa</i>								
<i>Offspring Phenotype</i>	<i>Normal pigmentation : Albino</i>								
<i>Phenotype Ratio</i>	<i>1              :              1</i>								

Part (c) required candidates to use the theory of natural selection to account for the fact that many antibiotics used to control tuberculosis are no longer effective. This part was poorly done as several candidates were unfamiliar with the role of antibiotics, the disease tuberculosis as well as with the theory of natural selection. Candidates were expected to explain that variation exists among bacteria that cause disease and some of

these bacteria were naturally resistant to the antibiotics. These bacteria would survive when persons take these antibiotics and be able to reproduce and produce offspring that are also resistant because they would inherit the genes. Eventually more surviving bacteria will be resistant to the antibiotics.

### Question 6

This question assessed candidates' knowledge of coordination and movement in animals, as well as accommodation by the eye (S.O. B6.6, 7.2(i), 7.5, 7.9). Performance on this question was also poor with a mean of **5** out of 15 marks.

In Part (a) (i), candidates were asked to name three types of tissue which coordinate to bring about movement in animals, then state three reasons why it is important for animals to be able to move. This was very well done as most candidates were able to name bones, muscle, connective tissue or nerve tissue. Finding food, a mate, escaping predators, finding favourable habitats were correctly identified as reasons animals need to move.

In Part (a) (ii), they were required to explain why plants are able to survive without moving from place to place unlike animals. This was also well done as candidates explained that plants use the raw material in their environment to make their food or their mates are selected by pollinators such as wind, water or animals.

In Part (b), candidates were asked to describe the changes that occurred in the eyes of a father to keep the face of his son in focus as his son stepped down onto a tarmac and ran towards him. This was poorly done by most candidates. Many candidates only described the pupil reflex which controls the amount of light entering the eye. They were expected to describe how accommodation occurs to allow the eye to adjust to see an object at different distances from the eye. In this case, candidates were to explain that when the son was far away from the father, light from the son's face entered his eyes through the pupils then fall on the retina. Light rays from the son's face are coming from a distance so they are almost parallel, hence they do not need to be bent or refracted too much. The ciliary muscles would be relaxed and increase the tension or pull on the suspensory ligaments. These ligaments pull on the lens in the eye causing the lens to become flat/thin. As the son approaches the father (gets closer), the light rays from his face become more divergent and need to be bent (refracted) more. The ciliary muscles in father's eye contract releasing the tension on the suspensory ligaments attached to the lens. The lens become more convex/bulge in order to bend the light rays unto the retina.

It was observed that many candidates did not spell the names of the eye structures such as ciliary muscle and fovea correctly.

## **PAPER 032 – Alternative to the SBA**

This paper assessed all of the practical skills required of biology students. Candidates continue to display weak practical skills especially in aspects of doing drawings, planning and designing including manipulating apparatus, describing methods of experiments, identifying limitations and in drawing conclusions from data. These observations suggest that many candidates *were not exposed to actual experimenting and investigation of scientific phenomena, discussing observations and giving explanations* so that students become capable of developing and manipulating experiments and experimental data on their own.

### Question 1

This question tested candidates' knowledge of the structure of a fruit, germination, asexual reproduction, (S.O. B2.5, 4.10, 4.11, 9.10, 9.11 and C2.1) as well as a range of their experimental skills. Performance was generally poor. Candidates were able to score a maximum of **29** marks of the 35 marks available. The mean for this question was approximately **11**.

In Part (a), candidates were provided with a drawing of a longitudinal section through a tomato fruit. Their ability to draw and label the longitudinal section through a tomato fruit at a magnification of X2 was tested. Although some drawings were accurate in their representation of the fruit, many were disproportionate in

representing the distance between the outer and inner wall of fruit, as well as the size and distribution of the seeds. Many candidates were also not awarded full marks because they did not use clean continuous lines or shaded structures such as the sepals. A few candidates were not familiar with how to calculate the magnification of their drawing nor did they use a ruler to check the magnification of their drawing to ensure it was in the range of two times the size of the original drawing as required. Many were unfamiliar with the parts of the fruit. The sepals were often labelled stem and the fruit wall was called a cell wall or cell membrane. Candidates are being reminded that label lines should be drawn with a ruler and should touch the structure being identified.

Part (b) required candidates to describe the procedure that was carried out to test the presence of food nutrients in a sample of tomato juice and based on the observed results stated, tell the conclusion for each test. Performance on this part of the question was very disappointing. Very few candidates described the sequence of each procedure for each food test correctly. In testing for reducing sugar using Benedicts solution, some candidates did not mention that the mixture should be heated. In describing the protein and starch tests, some candidates incorrectly said that after copper sulphate was added in the case of the protein test or after iodine was added in the case of the starch test, the mixture should be heated. In some instances, candidates did not test a sample of tomato juice as instructed but described reagents they used in class to do food tests such as glucose solution, egg white, vegetable oil and starch solution. Some candidates described the emulsion test using ethanol instead of the grease spot test, to test the juice for the presence of fat even though the observation mentioned that there was a water mark on the filter paper.

In Part (c), candidates were given a diagram of apparatus set up to investigate one of the conditions necessary for the germination of tomato seeds. One set of apparatus was set up in a transparent box at 29°C while the other was set up in a black box at 29°C. Part (i) asked candidates to write a suitable aim for this investigation. A few candidates did this part of the question well and only included one condition to be investigated but some candidates wrote the title of the figure provided in the question. A suitable aim that was awarded full marks was: *To investigate if tomato seeds need light to germinate.*

In Part (ii), they were asked to suggest two precautions that need to be taken to ensure that the results of this investigation are valid. This was also well done by most candidates. Precautions that were awarded marks included ensuring that the temperature for each apparatus is maintained at 29°C; ensuring that the cotton wool remains moist, ensuring the same number of seeds are used in each apparatus.

Part (iii) required that they explain the importance of moisture in the cotton wool. This part was not well known. Candidates had several misconceptions about the role of moisture in germination including that moisture was to allow for cooling or maintaining a constant temperature/environment for germination to take place or to provide oxygen. The moisture is needed for activation of the enzymes in the cotyledon of the seeds to breakdown food stores to provide nutrients for the developing embryo.

Part (iv) asked candidates to describe how the investigation could be modified to determine if oxygen is necessary for germination. Most candidates were awarded at least one of the two marks for mentioning that oxygen would be excluded from one of the tubes but only a few candidates were able to explain that this could be done by using pyrogallol to absorb oxygen or by using a rubber stopper/bung or paraffin to cover the test tube.

Only a few candidates were able to suggest that some seeds that were planted deep in the soil germinated but did not come up above ground because their food stores were limited or used up before the plumule was able to reach light to photosynthesize as was required in Part (v).

In Part (d), candidates were given drawings of six germinated tomato seedlings collected at different times after the experiment was set up. They were also told that the magnification of each drawing is x3. They were asked to measure the length of the radicle of each of the tomato seedlings and record the measurements in a suitable table in the space provided. Many candidates were able to construct tables with appropriate row and column headings to record their measurements. It was however evident that some did not measure only the length of the radicle as instructed but included the seed in their measurement. No mark was awarded if the measurement was incorrect. Candidates are being reminded that they should write the unit of measurement in the column or row heading and avoid cluttering the table by writing the unit beside each measurement.

Part (e) tested candidates' knowledge of asexual reproduction in plants. In Part (i) most candidates were able to name the type of reproduction carried out by the plant in the diagram provided as asexual reproduction. Candidates that referred to the process as self-reproduction were not awarded the mark. Very few however were able to suggest two advantages of asexual reproduction compared to the production of seeds for reproduction as required in Part (ii). Advantages that candidates were expected to suggest included:

- *Reproduction is faster because plants reproducing asexually do not have a dormancy period like seeds;*
- *Offspring will have favourable characteristics of the parents as they are genetically identical to them*
- *Asexual reproduction is likely to successfully result in the production of offspring unlike some seeds which may not germinate even if conditions are ideal because they are not viable.*

### Question 2

This question tested the candidates' knowledge of the structure of human vertebrae (S.O. B 6.5) and their ability to construct a table to represent data as well as to plot a suitable graph to represent data presented in a table. Candidate performance on this question was satisfactory with the mean score being **6** out of a possible 15 marks but the range of marks awarded to candidates was 0 to 14.

In Part (a), candidates were given drawings of two human vertebrae labelled A and B and asked to construct a table to compare any three characteristics of the two vertebrae. Performance on this part of the question was disappointing as most candidates were unable to correctly name and compare at least two of the three characteristics required. Candidates were expected to compare the shape and appearance of the neural spine, neural arch, centrum, transverse process, neural canal and or facets.

Performance on Part (b) was good. Candidates were given a table showing the average bone density of males and females between the ages of 25 and 85 years and asked to plot a suitable graph to represent the data in response to Part (i), then write a conclusion that could be drawn from the data represented by the graph drawn in Part (ii). Most candidates used an appropriate scale and used fully labelled axes (which included units) to draw their graphs. Some did not include a key to distinguish the female from the male data plots but most candidates plotted all the points correctly. A few candidates described trends observed instead of writing a conclusion as required in part (ii). Candidates were expected to conclude that bone density decreases with age or that the rate of bone density decline is greater among women than among men.

### Question 3

This question tested candidates' knowledge of the breathing process (S.O. B3.6) as well as their ability to draw a model of the human respiratory system using suitable apparatus. Performance in this question was disappointing. The mean mark was **3** out of **10** marks.

In Part (a) candidates were provided with a diagram of apparatus used to construct a model of the human respiratory system, namely two balloons, a bell jar, rubber sheet and a rubber stopper with Y-tube inserted. Very few candidates were able to draw an accurate representation of a model of the human respiratory system using the material provided. Clean continuous lines were rarely used to produce the drawings and many candidates were unable to get full marks because they shaded the rubber sheet or did not draw label lines using a ruler. Candidates were expected to draw a model similar to the one below:

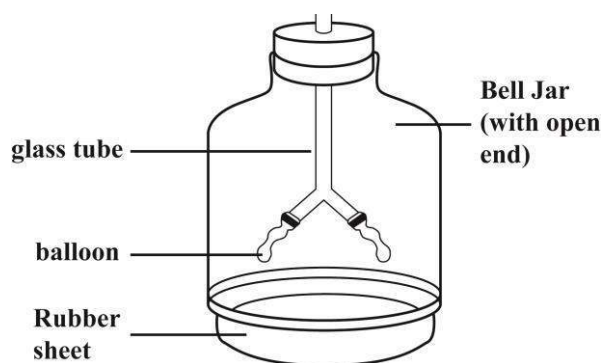

Most candidates were able to name the structure in the human respiratory system represented by the rubber sheet as the diaphragm in responding to Part (b).

Part (c) examined candidates' understanding of how the model could be used to demonstrate breathing in humans. This too was very poorly done by most candidates. Candidates were expected to mention that they would pull the rubber sheet downwards (to represent contracting of the diaphragm) in order to reduce the air pressure/increase the volume within the bell jar so the balloons would inflate to demonstrate inhalation of air; and that the rubber sheet could be pushed upwards (representing relaxation of the diaphragm) to increase the air pressure/decrease the volume within the bell jar so air is forced out of the balloons to demonstrate exhalation.

Teachers are again being encouraged to use models to demonstrate important biological processes such as breathing to help students clarify and understand important biological concepts.

### **PAPER 03 – School-Based Assessment**

#### **GENERAL COMMENTS**

Performance on the school-based assessment was commendable. Favourable trends which continue to be observed included: good syllabus coverage (i.e. a minimum of nine syllabus topics covered) by most centres; an increase in the number of centres where both quantitative and qualitative fieldwork were done and the number of times practical skills were assessed generally complied with syllabus guidelines. This suggests that most teachers recognize the value of providing sufficient opportunity for students to develop and master all the specific practical skills. However, while the skill of Observation Recording and Reporting (ORR) was generally well done, Drawing (Dr), Analysis and Interpretation (AI) and Planning and Designing (PD) continue to present candidates with the most difficulty.

While the level of organization and presentation of books submitted from most centres was good, there were still some centres that submitted books without the requisite information. The CXC Biology syllabus (page 44) provides guidelines for candidates' preparation of practical books for submission. Some important requirements often **NOT** met include: a Table of Contents with aims of the practical activities, page numbers, dates, and a clear and specific indication of the activities used for SBA and the skills being assessed. In addition, the marks awarded for each practical activity must be placed along with the practical and not simply listed at the front or back of the books.

The lack of comments in the lab books, especially for skills performed poorly suggests that students are not being given adequate feedback on their progress throughout the period of study. Oftentimes only ticks or the word 'Seen' are observed and the final score awarded for the skills but students appear unaware of their strengths or deficiencies.

The moderation exercise was often hampered by poor mark schemes. Teachers are being reminded that mark schemes must be legible and preferably bound together instead of being on loose sheets of paper. There must be a clear and direct relationship between the marks awarded to the appropriate activities in the practical

books and to the marks on the tally sheets. It should also be noted that no more than two skills should be assessed in a practical activity. New teachers in particular should consult pages 38 – 44 of the Biology syllabus for guidance in preparing and presenting mark schemes.

The following is a list of criteria which teachers should follow in marking SBA activities:

- Marks should be awarded for each skill separately. It is noted that in some cases, marks were given for the each skill then tallied to give a composite score. This is unacceptable.
- Marks awarded to students' work should be a fair indication of its quality. Too many students received high marks for work that fell short of the CXC standard. This was particularly noticeable for Planning and Designing and Analysis and Interpretation and Drawing. When the CXC standard is not observed there is great disparity between the teacher's score and that of the moderator. This circumstance is usually **disadvantageous** to the students.
- Marks submitted on the moderation sheet should reflect the candidates' marks in each of the samples. Consistency of marking and submission of marks relate to the reliability of the process and thus acceptability of marks submitted.
- Teachers are once again reminded that body fluids such as saliva, blood and urine are not to be used for practical work. These can be sources of infection and may have serious legal implications should a student become infected while conducting practical work. Plant materials must be removed from books before they are submitted to CXC, since these are also potential agents of infection when moved from place to place.

The examining committee would also like to recommend that there be greater cooperation among teachers of similar subjects at the same centre and mentoring of new teachers, to ensure consistency in standards is maintained.

A review of previous schools reports will provide additional suggestions for developing practical skills. Further suggestions are reiterated in this report and each teacher is alerted to the specific strengths and weaknesses displayed by their candidates in the Moderation Feedback Form sent to schools from CXC, after moderation. The moderation feedback form, which is sent to each centre, provides constructive and useful information relevant to the particular teacher(s). This form offers specific recommendations and is intended to assist teachers in planning, conducting and assessing practical work – in the laboratory and field. Improvement of students' practical skills will have a direct influence on candidate overall performance in the Biology examination, since certain questions, notable question 1 on Paper 02, are based on knowledge and application of these practical skills.

### **SPECIFIC COMMENTS ON THE ASSESSMENT OF SKILLS**

The following information is to assist especially new teachers of Biology in interpreting the information given on the CXC Moderation Feedback Report.

The number of times a skill is assessed is considered sufficient if assessed a minimum of 4 times (see page 37 of the Biology syllabus).

#### Observation, Recording, Reporting (ORR)

This skill appears to have been mastered at most centres. For most centres sampled, the method was clearly described with logical sequence of activities. It was also observed that except for a few centres, the past tense was correctly used in the presentation of the report on the practical activity (except for Planning and Designing ones as required). Candidates should be encouraged to give careful attention to grammar, quality of expression and giving as much details as possible when reporting their procedures and observations as science students need to appreciate the importance of clarity in explaining their results. Where possible, students should also be encouraged to repeat procedures and give average results to improve the reliability of their results.

The tables and graphs were usually clear and provided adequate details which allowed for clear description and discussion of the experiment. The Examining Committee recommends that teachers give more activities where students construct their own tables and graphs using their results. This will allow them the opportunity to develop these skills.

When using tables, teachers should remind candidates that the TITLE should be written before the table using CAPITAL LETTERS. The table must be enclosed and appropriate row and column headings should be given.

**Example:**

TABLE 1: FROG POPULATION OBSERVED FROM OCTOBER 1997 TO OCTOBER 2004

Year	Number of frogs
2004	5
2001	110
1997	125

When using graphs the TITLE should be written below the graph and underlined; axes should be labelled, with units stated and a key should be presented if necessary.

If calculations are required, all necessary calculations should be shown and these should be done and presented neatly and in an organized fashion. Units should also be included where necessary.

Where drawings are used in reporting observations, they should meet standard SBA drawing criteria although the skill is not being assessed.

#### Drawing (Dr)

The quality of drawings of candidates from most centres has shown some improvement, especially in relation to clarity of drawings. However, at too many centres poor drawings were awarded high marks. The Examining Committee does not expect drawings to be works of art, but they should meet the criteria for accuracy, proportions; clarity, labelling and magnification. Teachers should ensure that students are given several opportunities to practice and develop drawing skills.

It is a requirement that drawings must be practiced from actual specimens and not from textbooks. Specimens MUST include drawings of **flowers, fruits, storage organs and bones**. Additional examples may be included in practical books. However, **microscope drawings, models and apparatus should not be used for SBA assessment**. Drawings of cells while useful for teaching should not be assessed at this level but if taught, the calculation of magnification should also be emphasized. Similarly, dissections may help students to understand structures such as the digestive system but they are too complex to be drawn accurately at this level. These difficult drawings do not provide a fair test of ability at this level.

Table 1 is a list of 'Do's and 'Don'ts applicable to SBA biological drawings:



**TABLE 1. DO'S AND DON'TS OF BIOLOGICAL DRAWINGS**

Do's	Don't s
<ul style="list-style-type: none"> <li>• Use pencils for all Drawing activities – drawing, label lines, labels</li> <li>• Use drawings of actual biological specimen (not diagrams, models or textbook drawings); ensure for assessment there are drawings of flowers, fruit, seeds and bones</li> <li>• Let the size of drawings be at least half page</li> <li>• As far as possible, have label lines and labels positioned at right side of drawing</li> <li>• Let all label lines end at the same vertical plane</li> <li>• Let label lines be drawn parallel to the page top/bottom</li> <li>• Ensure label lines end on part being made</li> <li>• Write TITLE using CAPITAL LETTERS</li> <li>• In title, use word “drawing” and not “diagram”</li> <li>• Position title under the drawing and indicate the actual name of the specimen (e.g. cervical vertebrae of a goat, mango leaf, hibiscus flower) and the view drawn</li> <li>• Underline the title</li> <li>• Include the magnification and state where appropriate, actual length and width of specimen as well as place ‘x’ in front of the magnification</li> <li>• Write magnification to 1 decimal place</li> <li>• Use a key to explain symbols where appropriate e.g. stippling/cross hatching</li> <li>•</li> </ul>	<ul style="list-style-type: none"> <li>• no arrow heads</li> <li>• no crossing of label lines</li> <li>• no dots or dashes</li> <li>• do not join letters of words for label or title</li> </ul>

Accuracy and labelling continue to be problematic for candidates and there appears to be some degree of inconsistency - even among teachers at the same school - in how they are assessed. Label lines should be drawn with a ruler and as much as possible, labels should be written in script (not capitals) so that they can be easily read. Annotations should give the functions and descriptions of the structure where appropriate. Annotations that accompany drawings should be as brief as possible and clearly and neatly written.

The Examining Committee also encourages teachers to ensure that standard drawing criteria are applied whenever drawings are required in lab activities, especially when reporting observations and/or illustrating biological processes e.g. germination, regardless of whether DR skills are to be assessed or not. This should help students appreciate the importance of the skill.

Teachers should also ensure that students draw on plain paper and then neatly insert drawings into lab books, if the books are not designed with plain sheets of paper for drawing. Distinguishing features and labelling lines are oftentimes unclear when drawings are done on ruled sheets of paper.

### Analysis and Interpretation (AI)

This skill continues to present problems for the majority of candidates. Many teachers continue to use questions to stimulate discussion. This device is good for helping students to develop their AI skills. However, they should not be used excessively, nor should they be the only means of assessment. These questions must guide students to provide the required background information, give explanations for the results, draw conclusions and show an awareness of possible limitations. The information provided in this way should then be written up as a paragraph of continuous prose as is normally done for the discussion/conclusion. In many cases, candidates seem to have learnt a formula for writing up the discussion but showed no real understanding of how to interpret their own results. As a learning strategy teachers may ask their students to orally explain the results to obtain a clearer view of their understanding and to help them develop their analytical skills.

The marking criteria used by some teachers did not include ‘limitations’ as one of the criteria. It was sometimes observed that precautions/control/sources of error were often accepted as limitations by the teacher.

The use of controls should also be emphasized in discussions as they are a point of comparison for the experimental set up in which a particular variable has been omitted. This comparison should be included in the discussion as it is the key to drawing the conclusion. Conclusions should relate directly to the aim of the investigation. Students should also be reminded to discuss at least one limitation of the investigation. It is important for them to recognize that the conditions present in a school laboratory are rarely ideal.

The processes involved in demonstrating the AI skill are reiterated here:

- Background information may be written in the “Discussion,” or in the introduction section
- Background information for the experiment must be related to the theory
- Discussion should be an analysis or interpretation of the recorded experimental results. Discussion must not simply answer posed questions for AI:
  - a. questions may be used to guide students but answers must be written in paragraph format (without the questions or written comprehension style)
  - b. questions should not to be included in the lab report
- Conclusion must be based on the aim. (It is a brief answer to the aim)
- Limitation(s) should be included among the AI marking criteria as very important to labs
- Identifying source(s) of error and precaution(s) is necessary as is knowing that these are both different from each other and from limitation(s)
- All components of AI (background knowledge, explanation of results, limitations and conclusion should be included in the mark scheme for the skill)

The Examining Committee is again reminding teachers that food tests on their own are not appropriate for assessing AI. Simple investigations can be designed in which food tests are used. For example, students can be given unknown mixtures and asked to find out which food would be most suitable for an infant. Food tests can be used also to determine the presence of a particular food before and after digestion by an enzyme. These types of exercises will allow students to develop the necessary skills. Knowledge of the food tests and

the nutritional requirements can then provide the background information on which they will base their conclusions.

### Manipulation and Measurement (MM)

As has been the trend in previous years, this skill continues to be the one that most candidates appear to have achieved mastery of, based on the observation that most are awarded full marks. However, evidence such as performance on the practical question in the final examination suggests that these marks may not be the result of rigorous marking. Also if virtually all students in a class gain full marks on an activity, this suggests that the task may not be demanding enough or the criteria not detailed enough to allow the necessary discrimination between different levels of performance.

The Examining Committee recommends that teachers expose students to as wide a range of apparatus and their use in collecting data as is possible. This would help to ensure candidates' manipulation skills develop and allow for a more fair assessment of students' competence in MM.

### Planning and Designing (PD)

Performance on this skill has shown some improvement relative to former years and teachers should be commended for demonstrating more creativity in the types of observations/problem statements provided to students on which to base their hypotheses and design their experiments. The Examining Committee continues to emphasize the importance of using examples from students' local environment as this will help students better appreciate how they can apply their biological knowledge and practical skills to solve problems they frequently encounter. Teachers are reminded that it is inappropriate to have students copy procedures from textbooks and reproduce them verbatim for assessing students' PD skill.

The experiments designed by the students from some of the centres moderated, indicated that there was some understanding of the procedures involved in planning and conducting an experiment but in some instances, there were no replicates in the investigations. There are still a few areas of difficulty where candidates were unable to state their hypotheses clearly and relate the aim to the hypothesis. A hypothesis is an explanation based on particular observations, about how things work or why something happens.

It is also important that development of the skill start with the commencement of the teaching of the syllabus. In many cases it was obvious that practical activities targeting the development of the Planning and Designing skill was among the last set of activities in which the candidates engaged prior to the examinations. Figure 1 is an example of how a planning and designing activity might be effectively developed.

Figure 1. Example of a Good Planning and Designing Activity

**Example:**

This Planning and Designing activity submitted by one centre was based on the observation that “A boy notices that all the trees around his yard except the grapefruit tree were infested with ‘duck’ ants”. The students were required to plan and design an experiment to determine what was responsible for the difference in infestation. An example of an appropriate hypothesis and a relevant aim for investigating the hypothesis was:

***Hypothesis:** ‘Duck’ ants do not feed on grapefruit trees because the leaves contain a chemical that repels the ants.*

***Aim:** To find out which plant leaves ‘duck’ ants feed on  
(The aim of the subsequent investigation could be: To determine the presence of chemical X in different leaves.)*

There was a clear description of the materials and method. Students planned to use different leaves to see if the duck ants would respond as they do the grapefruit leaves. The ‘duck’ ants would then be placed in labeled containers containing the same number, sizes of leaves taken from a particular tree. A container with no leaves was an appropriate control. The measurable variable would be the number of ‘duck’ ants that leave or remain in each dish. Results would then be tabulated and subsequently discussed.

As stated by the candidates, one limitation may be that ‘the chemical in the leaves that cause the effect on the ‘duck’ ants may be affected by the extraction’. Appropriate marks were awarded for the various aspects of the experiment.

**CARIBBEAN EXAMINATIONS COUNCIL**

**REPORT ON CANDIDATES' WORK IN THE  
CARIBBEAN SECONDARY EDUCATION CERTIFICATE® EXAMINATION**

**JANUARY 2015**

**BIOLOGY  
GENERAL PROFICIENCY EXAMINATION**

## GENERAL COMMENTS

The January 2015 examination in Biology at the General Proficiency level was the 47th sitting of this subject conducted by the Caribbean Examinations Council (CXC). Biology continues to be offered at both the January and June sittings of the examinations. The biology examination is one of the more popular of the single sciences offered by the Caribbean Examinations Council at the CSEC level and assessed the performance of approximately 1200 candidates this year. The examination comprises three papers: Paper 01 — Multiple Choice; Paper 02 — Structured/Extended Essay paper; and Paper 03/2 — Alternative to School-Based Assessment (SBA), offered only to private candidates.

The overall performance of candidates this year was similar to that of 2014 with candidates scoring across the full range of marks on almost every question. Several candidates demonstrated above average knowledge of fundamental biological concepts and principles relating to digestion and diseases. Topics such as reproduction in flowering plants, genetics, homeostasis — temperature regulation, as well as practical based questions which require that candidates plan and design experiments, generate hypotheses or make representative biological drawings, still present major challenges for many candidates.

Candidates and teachers are being reminded to pay careful attention to the following recommendations made by the examining committee, reiterated in this, as well as in previous reports, in order to enhance the quality of their performance in these examinations:

- Review and become familiar with the glossary of terms at the back of the syllabus. This will aid understanding of key terms frequently used in questions such as *describe*, *explain*, *outline*, *identify* and *design*.
- Be guided by the mark allocation and quantitative descriptors within the text of the question to aid interpretation of what is being asked and minimize or prevent the giving of irrelevant information in responses.
- Biological jargon and the correct spelling of biological terms should be used as appropriate. Poor spelling of important biological terms sometimes prevents candidates being awarded marks and this needs to be emphasized by teachers.
- Teachers should try as much as possible to dedicate adequate time to the teaching and assessment of all topics and specific objectives covered in the syllabus. It was observed that many candidates performed poorly on questions that assessed knowledge of biological processes occurring in plants as well as in responding to questions related to cell division and genetics covered in section C of the syllabus.
- Teachers are encouraged to use a constructivist, enquiry-based approach in the teaching of biology to improve students' ability to think critically and solve problems independently, as well as to minimize the learning of content by rote.

The examining committee also wishes to encourage teachers and private candidates in particular, to support the teaching/learning of theoretical content with practical activities as well as the plethora of online resources via educational websites, YouTube and social media.

## DETAILED COMMENTS

### Paper 01 – Multiple Choice

Paper 01 consisted of 60 multiple-choice items. Performance on this paper was similar to that of previous years. Some of the topics that candidates found problematic were:

- Breathing in humans
- The concept of surface area to volume ratio
- Transport in plants
- Excretion in plants
- The structure and function of the parts of a dicotyledon seed

### Paper 02 – Structured and Extended Essays

Paper 02 consisted of six compulsory questions. Candidates' performance on this paper was similar to that on the January 2014 paper. Candidates were able to gain marks across the range of marks allotted for most questions.

#### Question 1

Specific Objectives: B6.1, 9.1, 9.7; C1.2, 2.3, 3.3

This question tested all three profile skill areas identified in the Biology syllabus – Knowledge/Comprehension, Use of Knowledge and Experimental Skills. It examined candidates' knowledge of types of reproduction in plants, mitosis and meiosis, genetics and germination. It also tested their ability to measure the radicle of a developing seedling accurately and plot the data using a suitable graph as well as design a suitable experiment to test a hypothesis. Most candidates attempted this question and were able to access marks across the range from zero to 23 of the 25 marks; but performance was below expectations. The mean was approximately 9 out of 25 marks.

In Part (a), candidates were given two drawings of plant organs: one was a stem tuber with buds and the other was a flower with an anther labelled. Most candidates were able to correctly identify the type of reproduction carried out by the stem tuber as asexual reproduction and sexual reproduction by the flower as required in Part (a) (i). Part (a) (ii) was more challenging as very few candidates were able to accurately outline the sequence of events that takes place after pollination leading up to formation of a seed and/or fruit. In some cases, candidates did not describe the events using biological terms and used general terms such as 'the pollen moves down a tube and enters the ovary where fertilization takes place' without making reference to the pollen tube, pollen/male nuclei, micropyle or ovule.

An example of a candidate's response that scored full marks was:

*When the pollen grain lands on the stigma, a pollen tube grows down the style and enters the ovule inside the ovary via the micropyle. The pollen divides into two male nuclei while in the tube. One nucleus fertilizes the ovum inside the ovule and*

*a zygote is formed. The integuments of the ovule harden and become the testa or seed coat and the ovary becomes the fruit whose walls are called the pericarp.*

Several candidates were awarded at least half of the four marks allotted to Part (b) for accurately describing at least one of the two differences between the outcomes of cell division by mitosis and meiosis. Some candidates did not pay attention to the term *outcomes* in the question and described where the processes occurred. They were not awarded marks. Most candidates stated that mitosis results in the production of two cells while meiosis results in the production of four cells. Good candidates usually added that the two cells produced by mitosis were identical but the four produced by meiosis were non-identical to each other. A few candidates also included that diploid cells were formed from mitosis but haploid cells were formed from meiosis.

Part (c) tested candidates' ability to deduce the genotypes of the parent plants with blue flowers that were crossed to produce blue and white flowered plants in a ratio of approximately 3 blue-flowered plants to 1 white-flowered plant. This was poorly done by several candidates. Many candidates recognized that the flower colour that was produced in larger quantities among the first generation of plants was likely to be the dominant allele. However, many candidates used inappropriate symbols to represent the blue and white alleles. The convention when selecting and writing symbols to represent alleles is to use upper case letters (which usually is the first letter of the dominant phenotype) to represent the dominant allele and the lower case form of the same letter to represent the recessive allele.

A response that was awarded full marks was:

*Blue flower genotypes may be homozygous or heterozygous while the white colour trait is produced in smaller amounts and is likely to be recessive. If the blue-flowered parents were homozygous, none of the offspring would be white.*

*Parent Phenotype:                      blue                      x                      blue*

*Parent Genotype:                      Bb                      x                      Bb*

*Gametes                                      B              b              x              B              b*

*Punnet Square:*

	<b>B</b>	<b>B</b>
<b>B</b>	<b>BB</b>	<b>BB</b>
<b>B</b>	<b>Bb</b>	<b>bb</b>

*Offspring:              Blue (BB and Bb) flowered plants and white (bb) flowered plants*

In Part (d), candidates were given a diagram showing a seedling at different stages of growth over an eight-day period. In Part (d) (i), many candidates accurately measured and recorded the length of the radicle in centimetres but some candidates were not awarded the marks because they included the seed in their measurement and got incorrect results.

Part (d) (ii) required that candidates plot the data in the table on the grid provided. Most candidates accurately plotted the data but a few candidates were unable to get full marks because they used an



inappropriate scale or did not include the unit of measurement when labelling the axes. In Part (d) (iii), several candidates were awarded at least one mark for stating that oxygen is another factor, other than water, that is required for the germination of seeds. The other condition required is a suitable temperature or warmth.

Several candidates stated that carbon dioxide, sunlight (*lettuce seeds are an exception*), soil and wind are required for the germination but these responses are incorrect. Candidates who said temperature and climate (which were too vague) were also not awarded marks. Part (d) (iv) investigated candidates' ability to describe a procedure to test the hypothesis *Water is needed for the germination of seeds*. This was poorly done by the majority of candidates. Most candidates were able to get at least one of the four marks for placing seeds in moist and dry conditions but their description of the procedure as well as their description of how the apparatus is set up was usually inadequate.

Candidates were expected to use moist and dry materials such as cotton wool, filter paper, paper towels or soil to set up moist and dry conditions and equal numbers of seeds should be used in each case. They were also expected to mention that other environmental factors such as temperature and air should be the same in both cases.

Part (e) tested candidates' knowledge of the role of the cotyledons (seed leaves) during germination. Many candidates only got one of the two marks allotted because they were unable to give a full explanation of why the cotyledons become smaller as the primary leaves increase in size. Many seemed unfamiliar with the role of the cotyledons. Some had the misconception that cotyledons protect the embryo.

A candidate's response that was awarded full marks was:

*The cotyledons are a food reserve and get smaller as enzymes activated by water breakdown the food to provide the nutrients for the leaves to grow bigger. They support the plant until the leaves are big enough to photosynthesize and nourish the plant.*

## Question 2

Specific Objectives: B2.6, 2.8, 2.11, 5.3

This question examined candidates' knowledge of the human alimentary canal, protein digestion, the role of protein and the nitrogen cycle. Candidate performance on this question was satisfactory. While candidates were able to access marks across the full range of the question, their performance showed a mean of 8 out of 15.

In Part (a) (i), candidates were asked to identify five structures labelled I to V in the diagram of the human alimentary canal. This was well done but many candidates did not indicate that the stomach and small intestine/duodenum were sites where protein digestion takes place as required in Part (a) (ii). They incorrectly identified the liver, pancreas or colon as sites of protein digestion and were not awarded marks. Part (a) (iii) was also well done by many candidates who knew that the enzymes responsible for the digestion of proteins were only active in those locations: pepsin in the

stomach and trypsin in the small intestine; and the pH and other conditions are ideal for optimal enzyme activity at those sites.

A candidate response that was awarded full marks was:

*Protein digestion by the enzyme pepsin is suitable in the stomach due to the optimum acidic pH as a result of hydrochloric acid produced there. It also takes place in the small intestine (duodenum) where trypsin from the pancreas works at optimum pH.*

Most candidates were awarded at least one of the two marks for Part (a) (iv) for identifying growth as a reason why living organisms need protein. Other responses that were awarded marks included *repair of damaged tissues and cells, manufacturing enzymes, hormone synthesis and making antibodies*. A common misconception was that protein is needed to strengthen bones and teeth.

Part (b) examined candidates' ability to explain how nitrogen in waste such as urea excreted by some animals is made available to plants. This part of the question was especially difficult for candidates who were not familiar with the role of the various bacteria involved in the nitrogen cycle. Candidates were expected to explain that the urea is decomposed or broken down by soil bacteria to produce an ammonium compound which is oxidized to nitrites, which are further oxidized to nitrates by nitrifying bacteria. These nitrates are in a form that can be absorbed and used by plants to get nitrogen for making proteins.

Candidates were able to score at least one of the two marks allotted to Part (b) (ii) for identifying *yellowing of leaves* as a sign of nitrogen deficiency in plants. *Poor or stunted* growth was the other correct response awarded marks. Inaccurate responses frequently observed were: discoloured leaves, wrinkled leaves, leaves constantly falling off and thin yellow stalks.

### Question 3

Specific Objectives: C 5.1; D1.1, 2.1, 2.2, 2.3

This question tested candidates' knowledge of diseases. Candidates' performance on this question was good and the mean was 9 out of a possible 15 marks.

In Part (a), candidates were given a list of terms and required to use them to complete a concept map on diseases. This was well done by most candidates. Errors observed included that physiological diseases are caused by microorganisms instead of damaged organs and immunization can be categorized as 'artificial' instead of the correct term, *active*.

Part (b) which asked candidates to suggest three ways in which physiological diseases may be managed was usually well done. Correct responses frequently given and awarded marks included *surgery; lifestyle changes — exercising, eating healthy, not smoking; taking medication; dialysis; physical/counselling therapy and regular checkups/visits to the doctor*. Candidates who mentioned the use of condoms which prevent pathogenic diseases were not awarded marks for their response.

Most candidates correctly identified genetic or hereditary diseases as the category that would be appropriately treated by gene therapy in Part (c) (i). However, very few were able to suggest one

of the two ways other than gene therapy in which genetic engineering is used for the prevention and treatment of diseases. Incorrect responses included injections and tablets. A few candidates correctly mentioned that *genetic engineering can be used to manufacture drugs such as insulin*. Other responses expected were *the manufacturing of vaccines; synthesis of disease resistant crops; genetically engineered insect vectors to reduce transmission of vector-borne diseases or synthesis of foods with higher nutritional value to combat nutrient deficiencies; use of stem cells which could be genetically modified and used to produce new organs for transplant*.

Part (d) (i) required that candidates name two diseases transmitted by a named insect vector. Most candidates were able to correctly name two insect-borne diseases but the insect vector was sometimes incorrectly named. It was observed that diseases such as dengue and malaria, as well as the names of vectors: *aedes aegypti*, *anopheles* mosquito, were frequently misspelt. Part (d) (ii) which required candidates to suggest two measures that could be used to control the population of the insect vector was well known but many scored only one of the two marks because their response did not name a specific strategy to control a specific life stage of the vector such as *using chemicals to destroy the adult insect or removing garbage to reduce breeding site for flies*.

#### Question 4

Specific Objective: B2.3, 4.6, 4.8, 4.9, 5.6

This question dealt with the internal structure of the leaf and adaptations for water conservation. Performance on this question was disappointing as illustrated by a mean of 4 out of 15 marks.

Candidates were given diagrams of the internal structures of leaves from two plants growing in different environmental conditions. In Part (a), they were required to identify the structures labelled P, Q and R and state the role of each in photosynthesis. Most candidates correctly identified P as the *palisade mesophyll/layer* but some were unable to state that *these cells contain numerous chloroplasts/chlorophyll for trapping sunlight required for photosynthesis*. Few candidates were able to correctly identify Q as *xylem tissue which transports water to the leaves for photosynthesis*; or R as *phloem tissue required to translocate manufactured sugars/food produced from photosynthesis*.

Part (b) was also not well done. This part of the question asked candidates to describe one difference in the cuticle and one difference in the lower epidermis of the two plants in the diagram. Many candidates were able to correctly identify the differences in the thickness of the cuticle of both plants and suggested that this *allowed the leaves of plant B to lose less water via transpiration*. Very few candidates identified the *sunken stomata, the pits or presence of epidermal hair in B which allowed the leaves of plant B to reduce transpiration*. These features were absent in the lower epidermis of A.

A candidate's answer that was awarded full marks was:

*The waxy cuticle of B is much thicker than that of A suggesting that plant B has adapted to prevent water loss. Such an adaptation suggests that plant A is subject to more water loss than B. The stoma in the lower epidermis of B is sunken reducing water loss by transpiration as the epidermal hairs create a*

*microenvironment that is cool. The stoma of plant A is not so adapted again suggesting that plant B is subjected to less water/rainfall than plant A.*

In Part (c), most candidates were able to score at least two of the five marks for correctly suggesting that *plant A is likely to be found in well-watered, tropical conditions such as a tropical forest, near a pond, on a farm or in a garden; while plant B is more likely to be found growing in dry, desert or rocky conditions.* Few candidates were able to correctly name three adaptations in plant B not shown in the diagram that would be expected. Expected responses included *having roots growing deep into the ground, having few or small leaves and having needle like or spiny leaves or having succulent leaves/stems to store water.*

### Question 5

Specific Objectives: B 5.5, 7.11

This question tested candidates' knowledge of the anatomy of the human skin, homeostasis and temperature regulation. Performance on the question was poor with the mean mark obtained being 5 out of 15 marks.

In Part (a), candidates were asked to draw a clearly labelled diagram to show the internal structure of human skin. This was poorly done. Many candidates did not produce drawings that were representative of the human skin. The epidermis and dermis were sometimes not distinguishable and the position of the erector muscle and sebaceous gland in relation to the hair and/or hair follicle, as well as the position of blood capillaries and nerve endings, were often incorrect. The relative thickness of the epidermis compared to the dermis and the size of the sweat pores in proportion to the drawings were also incorrect. The terms *sebaceous*, *malpighian* and *follicle* were sometimes spelt incorrectly.

In Part (b) (i), candidates were asked to explain how the skin of a biologist who travels to the Sahara desert to study its organisms allows him to maintain a relatively normal body temperature during his first day and night in the desert. They were also asked to state the term used to describe the maintenance of a constant body temperature. Most candidates correctly identified the maintenance of a constant body temperature as *homeostasis* but a few mentioned osmoregulation and were not awarded a mark. (Osmoregulation is an example of homeostasis but involves regulation of the osmotic potential of body fluids to maintain a balance in water content between the inside and outside of cells.)

Several candidates were able to score at least four of the six marks allotted for their description of how body temperature was regulated. Some candidates were not awarded marks because although they correctly identified the structures involved in temperature regulation, they interchanged the events which take place during the day and night.

A candidate's response that was awarded full marks was:

*In the day time his blood vessels (capillaries) enlarge (dilate) so that the blood comes closer to the skin so that it will be cooled as heat is lost to the outer atmosphere. His sweat glands excrete sweat which cools the skin as it evaporates. Also, the erector muscles on his hair roots relax so that no hot hair is trapped on*

*his skin. However, at night when it is cooler, his blood vessels decrease (constrict) in size to conserve heat and the erector muscles on the hair roots of the skin contract to raise hair up to trap air to keep a warm layer of air around the body to insulate it. This process is homeostasis.*

Part (b) (iii) was usually well done as most candidates recognized that the biologist could make adjustments during the day such as *reducing his level of activity, staying out of direct sunlight by staying in the shade or wearing a hat/light clothing*. During the night he could *wear warm clothing, sleep under a thick blanket or increase his level of activity*.

A good candidate response was:

*At day he should do less movement and wear thin clothing; and at night do more active tasks and wear thick clothing to help regulate his body temperature.*

### Question 6

Specific Objectives: E1.1, 3.1, 3.2, 5.1, 5.2

This question assessed candidates' knowledge of organisms living in different natural habitats, ecological sampling techniques, factors that contribute to environmental variation and affect the population of organisms living in a mangrove swamp. Performance on this question was also disappointing with a mean of 7 out of 15 marks.

Most candidates were awarded full marks in Part (a) (i) for correctly matching organisms named in the first column with their natural habitat in the second column. In Part (a) (ii) however, most candidates were only able to score one of the two marks for their description of a technique for sampling organisms in the pond. The mark was usually awarded for naming suitable apparatus such as *nets, buckets, jars or rope/line transect*. Very few candidates explained how the apparatus could be used to sample the pond organisms. Candidates were expected to explain that *nets could be swept or buckets/jars could be dipped at regular intervals in the pond and the organisms collected and counted*. They could also have described the capture–recapture method.

In Part (b), candidates were asked to explain three factors that may have caused low yields of a tomato crop planted 10 cm apart compared to a crop that was planted 30 cm apart, even though the variety of tomato was the same, the plots of land were identical in size and located next to each other and equal amounts of water and fertilizer were given to the two sets of crops. Most candidates were awarded half of the six marks for identifying three contributing factors but very few candidates provided explanations as required. *Competition for light, space, water or mineral nutrients* were correctly identified as factors that may limit crop yield among plants growing close together. Some candidates correctly stated that *the transfer of pathogens was easier among the crops growing close together and the resulting disease would limit productivity of the tomato plants*.

Part (c) which required that candidates suggest three ways by which humans could adversely affect an oyster population living in a mangrove swamp was well done. Human activities correctly explained included *over-harvesting; killing of oysters by persons hunting for pearls; cutting down mangrove trees which would destroy the habitat; breeding site and food source for oysters that*

*live, reproduce and may feed on their roots; agricultural and industrial activities near to mangrove swamps result in harmful chemicals washing into the mangrove swamps and may be toxic to oysters.*

### **Paper 032 – Alternative to School-Based Assessment (SBA)**

This paper consisted of three compulsory questions that assessed all of the practical skills required of biology students. Candidates continue to display weak practical skills especially in drawings, planning and designing feasible methods for experiments that investigate biological phenomena, writing hypotheses, identifying precautions, interpreting data and drawing conclusions. These observations suggest that many candidates *did not have the practical experience required to develop these skills*. These skills would also enable them to design experiments and manipulate experimental data on their own.

#### Question 1

Specific Objectives: B2.5, 2.6, 2.7, 9.9, 9.10

This question tested candidates' ability to draw a bean seed at a specified magnification, perform food tests and design experiments to investigate enzyme activity under various conditions. Candidates were able to score a maximum of 22 of the 23 marks available. The mean score awarded for this question was approximately 8.

In Part (a), candidates were given a drawing of a bean seed and instructed to make a drawing of the seed that was twice the size of the one given. Most candidates were able to score at least one of the three marks allotted for producing drawings with magnifications that were about twice that of the original drawing. Several candidates were unable to get the marks allotted for producing representative drawings with the shape of the bean, the position of the embryo and relative proportions of the various bean structures similar to those in the original drawing, or using clean continuous lines.

In Part (b), candidates were told that students wanted to investigate the food substances present in the cotyledon (structure labelled C) of the bean seed before and after it germinated. In Part (b) (i), candidates were given the name of the nutrients to be investigated in the first column of a table and the resulting observations for each test were described in the third column. They were then required to describe the correct procedure for carrying out the various food tests in the second column.

Most candidates were able to score at least one of the four marks allotted for mentioning that *iodine/potassium iodide was dropped onto the cotyledon to test for starch*. Several candidates were not awarded marks for their description of the reducing sugar test because although they added Benedict's solution to a suspension containing the seed cotyledon, they did not include heating the mixture as the final step in their procedure.

Many candidates did not first include the addition of sodium or potassium hydroxide before adding drops of copper sulphate when describing how they would test for protein. Very few candidates correctly described the emulsion test for the presence of fat. Candidates were expected to first add alcohol (which dissolves fat) to the seed mixture, shake it up thoroughly, then pour the liquid part of the resulting mixture into another test tube containing distilled water to observe fat globules.

Several candidates incorrectly mentioned that they would heat the mixture after alcohol was added. *Please be reminded that this is potentially dangerous as alcohol is flammable, especially when exposed directly to heat.* Part (b) (ii) that required candidates to draw conclusions about the nutrients stored in the cotyledon based on the observations described in the table was well done by most candidates who stated that *protein, fat and starch were stored in the structure.*

Part (b) (iii) was also well known as most candidates were able to suggest at least one use of each of the food nutrients for the developing embryo. *Reducing sugar provides energy to the developing embryo when broken down during respiration; protein provides the raw material for growth and development of new cells and tissues; fat also is a source of energy but also aids in the formation of cell membranes, and starch is a source of energy when hydrolysed to sugars.*

Most candidates were awarded one of the two marks allotted to Part (c) for correctly suggesting that *the type of enzyme involved in the reaction that caused an orange precipitate to be observed when the sugar test was repeated after the seed germinated was amylase or a carbohydrase.* The enzyme is responsible for breaking down starch that is converted to maltose/glucose which are reducing sugars, and would give an orange precipitate when tested with Benedict's reagent.

Candidates' ability to design an experiment to investigate how temperature affects the activity of the enzyme, amylase, was tested in Part (d) (i). They were given a list of apparatus and materials and expected to describe how they would be used in the experiment but this part of the question was poorly done. Candidates were expected to explain that *the mortar and pestle were to be used to crush a sample of seeds into a paste which would then be added to some distilled water to make a suspension/mixture.* The mixture should then be placed into different test tube/containers and each container should then be placed in water baths maintained at different temperatures (monitored using a thermometer).

Equal amounts of the enzyme, amylase, should be added to each sample and a subsample of each mixture immediately tested either for the presence or absence of either starch or reducing sugar. The remaining portion of each mixture should be given equal time to react. At the end of specified time intervals, samples of each mixture should be tested either for the presence or absence of starch or reducing sugar using appropriate reagents. Candidates could have added iodine to the initial mixture before the enzyme was added and compared the rate at which the blue/black colour disappeared in each test tube held at the different temperatures.

Most candidates were able to correctly identify two suitable precautions that should be taken to ensure that accurate results were obtained in Part (d) (ii). Expected responses that were awarded marks were: *ensuring that equal amounts of enzymes/substrates and/or reagents were used; using thermometer to ensure the correct temperatures were being maintained in each water bath and preventing contamination of the mixtures.*

Part (e) was well done and most candidates were able to state that protein would be absent in the small intestine after one hour because most of it was digested in the stomach and absorbed from the small intestine.

## Question 2

Specific Objectives: A2.5, 2.8; E 1.2, 2.2

This question dealt with an investigation testing candidates' knowledge of soil, the response of soil organisms to environmental factors such as light. It also assessed candidates' ability to write a suitable hypothesis based on observation of biological phenomena. Candidate performance on this question was satisfactory with the mean score being 12 out of a possible 20 marks.

In Part (a), candidates were told that a farmer wants to choose an area to plant vegetables and took samples of top soil from two different locations to determine the soil composition in each location. They were given diagrams showing the layers of soil components which resulted from each test in the laboratory. Part (a) (i) required that candidates use the results to suggest which area would be more suitable for the farmer to plant vegetables and give a reason for their answer. This was well done as most candidates identified *area A as being better suited for planting vegetables as it contains humus which provides nutrients that aid growth and development of the plants as well as improves the water holding capacity of the soil*. Other reasons that were awarded marks were: *the amount of air and water in the soil at A would be better for the growth of the vegetables compared to B where less clay, more sand and gravel may encourage greater seepage of water from the soil*.

Candidates were also able to outline a suitable procedure for obtaining the results of the soil composition tests shown in the diagram as *required in Part (a) (ii)*. Good candidates were careful to explain that *equal soil samples were collected from each location, A and B, and weighed then placed in large measuring cylinders/beakers. Equal volumes of water were added to each sample and stirred with a stirring rod then allowed to stand for the particles to settle into place*.

In Part (b), candidates were given drawings of apparatus and materials used to extract organisms from the soil. In Part (b) (i), they were asked to draw a labelled diagram to show how the apparatus and materials could be set up to extract the animals that inhabit the soil. Candidates who were familiar with the Tullgren funnel were able to get full marks for producing *representative drawings showing a flask containing alcohol with a funnel inserted in the flask, the wire mesh inserted into the top of the funnel and the light source directly above the funnel*. Some candidates lost a mark because they did not use straight lines to label their drawings.

In Part (b) (ii), most candidates were awarded one of the two marks allotted for stating that *the lamp in the experiment provided light or heat as a stimulus to cause the animals to move out of the soil and into the flask of alcohol*. Many candidates also scored full marks for accurately *plotting a bar graph with the bars separated from each other to represent the data of the number of various soil organisms extracted from the soil that was presented in the table*. A few candidates were unable to get full marks because they did not label the axes or separate the bars drawn. Part (b) (iv) required that candidates write a hypothesis for the observation that when the soil samples were poured out onto a tray, some small insects quickly crawled back into the soil. A hypothesis is an explanation for observations made that can be scientifically tested to either support or falsify the



explanation. An example of a suitable hypothesis for this observation is that *soil organisms prefer dark conditions compared to well-lit conditions*.

Part (c) tested candidates' ability to use information presented in the form of a food web to explain how a population of fungi and that of arthropods would be affected if all the nematodes were killed by a pesticide. This was well done and candidates suggested that *the number of fungi may initially increase as one of their predators was removed but the number of arthropods may decline or remain the same since only one of their food sources is removed and that there may be increased competition for fungi*.

### Question 3

Specific Objectives: B1.5, 1.6, 6.6, 7.2

This question tested candidates' knowledge of types of movement, diffusion and osmosis. Performance on this question was also satisfactory. The mean mark was 9 out of 17 marks.

In Part (a), candidates were given two drawings depicting movement by a plant exposed to unidirectional light over a one-week period in the first drawing and termites moving within the bark of a tree in the second. They were required to tell the difference between the types of movements shown in Part (a) (i). Most candidates scored the two marks allotted for stating that *the plant demonstrated growth or part movement while the termites showed whole body movement or locomotion*. Many candidates ignored *type of movement* in the question and gave responses which suggested why movement occurred, that is, to produce food or to grow towards light in the case of the plant and go to a dark place or in search of food in the case of the animal. Very few candidates were awarded marks for writing a suitable hypothesis for the appearance of the new roots of the plant in the first diagram after one week. An example of a well written hypothesis was: *New roots grow towards moisture present in soil*.

In Part (b), candidates were given a diagram showing the apparatus used by students in a laboratory to illustrate the process of diffusion using a crystal of copper sulphate in a beaker of water. In Part (b) (i), they were required to outline a procedure using the apparatus and materials shown in the diagram identified as Figure 6, to investigate the hypothesis, *temperature increases the rate of diffusion*. Many candidates were awarded two of the allotted four marks for stating that beakers with equal volume of water were set up and a crystal of copper sulphate was added to each. They were also expected to state that the beakers should be maintained at different temperatures and the time taken for the blue colour of the crystal to completely spread throughout the water recorded and compared. Most candidates were awarded full marks in Part (b) (ii) for accurately *plotting the data of time taken for copper sulphate particles to spread at different temperatures on a line graph* but a few candidates were unable to get full marks because they did not use an appropriate scale that would have allowed them to use up more than 50 per cent of the grid provided; or they did not include units in the axes labels; or they did not put temperature on the *x* axis. Several candidates were able to correctly predict the time it would take for the particles to diffuse throughout the water at 90 °C as required in Part (b) (iii) by extrapolating from the graph they plotted in Part (b) (ii). Many candidates also estimated a time which fell into the range and was awarded the mark although it was obvious that they did not extrapolate from the graph. Most candidates also scored full marks for concluding that *increasing temperature increases the rate of diffusion of particles* in response to Part (b) (iv).

Part (c) was well done by most candidates. This question examined candidates' ability to distinguish diffusion from osmosis and predict the direction of movement of water molecules through potato tissue. Candidates were given a diagram, identified as Figure 7, showing an experiment set up to investigate osmosis in potato tissue. A concentrated sugar solution labelled X was poured into a cup formed from scooping out the middle of the sample of potato. The potato was placed to sit in a petri dish containing distilled water labelled Y. In Part (c) (i), most candidates were able to accurately predict that *the level of X would increase and the level of Y would decrease after one hour*. Part (c) (ii) asked candidates to compare the two processes by which particles are moving in the experiments illustrated in Figures 6 and 7. Most candidates were awarded full marks for stating that *Figure 6 demonstrated diffusion which did not involve movement across a membrane while Figure 7 demonstrated osmosis which involves water molecules moving along a concentration gradient and across a selectively permeable membrane which restricts movement of the sugar molecules*.

**C A R I B B E A N E X A M I N A T I O N S C O U N C I L**

**REPORT ON CANDIDATES' WORK IN THE  
CARIBBEAN SECONDARY EDUCATION CERTIFICATE® EXAMINATION**

**MAY/JUNE 2015**

**BIOLOGY  
GENERAL PROFICIENCY EXAMINATION**

**Copyright© 2015 Caribbean Examinations Council  
St Michael, Barbados  
All rights reserved.**

## GENERAL COMMENTS

The May/June 2015 examination in Biology at the General Proficiency level was the 48th sitting of this subject conducted by CXC. It was also the first year that candidates' performance on the new CSEC Biology syllabus implemented in September 2013 was being assessed. Biology continues to be offered at both the January and June sittings of the examinations and continues to be one of the more popular of the single sciences offered by the CXC at the CSEC level. The performance of approximately 17,000 candidates was assessed this year. The examination comprises four papers: Paper 01 – Multiple Choice; Paper 02 – Structured/Extended Essays; Paper 03 – School-Based Assessment (SBA); and Paper 032 – Alternative to SBA (offered only to private candidates).

The overall performance of candidates this year was lower than that of 2014. Many candidates demonstrated above average knowledge of fundamental biological concepts and principles relating to topics such as photosynthesis, digestion in humans, the female reproductive system and inheritance of traits such as albinism. However, topics such as ecological sampling methods, cell specialization, mitosis and meiosis, the function of the human eye as a sense organ, homeostasis, genetic terms, speciation and natural selection, as well as practical based questions which require that candidates plan and design experiments or make drawings, still present major challenges for many candidates.

The examining committee observed a significant decline in the performance of candidates on the practical question – Question 1 of Paper 02, and the SBA. Teachers are being encouraged to use practical activities to support the teaching of theoretical content and not to treat them as a separate activity. Teachers could use an inquiry based approach by posing a question then encouraging students to develop possible hypotheses, carry out the investigation then explore the theories. This will enable students to write critical discussions on their observed results and arrive at logical conclusions.

It appeared that several candidates were not familiar with the topics related to speciation and biological evolution contained in Sections A and C of the syllabus. Teachers are being encouraged to dedicate adequate time to the teaching of the entire syllabus, especially the topics not previously taught at the CSEC level.

The revised syllabus contains explanatory notes that outline the relevant content to be covered for each specific objective (SO). *Careful attention should be given to explanatory notes that make reference to specific objectives related to other topic areas in other sections of the syllabus.* This will enhance students' ability to transfer knowledge from the particular topic and apply it to develop their understanding of related concepts as well as increase their ability to think critically and improve their problem-solving capabilities.

*A word of caution to teachers, however, is not to restrict the teaching of the subject purely to the content outlined in the explanatory notes of the syllabus.* As technology continues to improve the ability of scientific research to enhance and sometimes change our understanding of biological phenomena and biological principles relating to topics such as genetics, health and the environment, teachers are encouraged to keep abreast of the rapidly changing information and engage students in more discussions to deepen their appreciation of the relevance of the subject area to their lives.

## DETAILED COMMENTS

### Paper 01 – Multiple Choice

Paper 01 consisted of 60 multiple-choice items. Performance on this paper was satisfactory and quite similar to that of 2014.

Some of the topics that were *most* problematic for candidates were:

- Transport in plants
- Storage organs in plants
- Transpiration
- Speciation
- Natural selection

## Paper 02 – Structured and Extended Essays

Paper 02 consisted of six questions, three of which were in the structured response format and three in the extended essay format. This paper tested all profile skill areas identified in the Biology syllabus. All questions were compulsory. Candidates were able to gain marks across the range for all questions and the mean for almost every question was relatively close to the midpoint of the range. Question 6 (which focused on biological evolution and natural selection) was a notable exception in that, although some candidates gained close to full marks, many more scored low marks resulting in a mean of 3.

### Question 1

This question tested all three profile skill areas identified in the Biology syllabus — knowledge/comprehension, use of knowledge and experimental skills. It examined candidates' ability to describe sampling methods used to estimate species abundance (SO A2.1), as well as construct a food web and a pyramid of numbers using data on the feeding behaviours of organisms found in a field study (SO A3.1, 3.5). The question also examined candidates' ability to describe an experiment to investigate the water holding capacity of soil (SO A2.3) as well as extract soil organisms (SO B7.2). Knowledge of the importance of soil to living organisms and decomposers in an ecosystem (SO A3.6, 5.1) were also tested. Most candidates attempted this question and were able to access marks across the range from zero to 25, but performance was below expectations. The mean was approximately 12 out of 25 marks.

In Part (a), candidates were asked to describe two sampling methods that could be used to estimate the abundance of plant species in an area located on the boundary between a savannah and a forest. Most candidates were only able to get two marks for naming two pieces of equipment that could be used in Part (i), namely a *quadrat* and/or a *line transect*. Few were able to also describe that *the quadrat should be thrown randomly in the area and the species counted/recorded*, or that *the line transect is pegged at a specific point and extended across the area. The species touching the line/found along the line are to be counted/recorded*. For Part (a) (ii), candidates were expected to describe how equipment such as nets, pitfall traps or tracking devices could be used to collect data on mobile animals inhabiting the area. The mark-capture release-recapture method was awarded full marks if it described the counting of the recaptured animals. Many candidates were unable to get marks because they only mentioned observing or counting the animals. The word *quadrat* was often misspelt.

Part (b) (i) examined candidates' ability to construct a food web. This was well done by most candidates but a few candidates used lines instead of arrows and some did not orient the arrows in the correct direction from prey/food to consumer. Candidates should be discouraged as much as possible from allowing lines to cross each other as this can lead to confusion. Part (b) (ii) was also well done as most candidates put the total number of organisms at each trophic level and drew each level of the pyramid getting proportionately smaller from bottom to top. Some candidates only included the names of the organism and lost one mark.

Part (c) (i) examined candidates' ability to describe an experiment to investigate the water holding capacity of a sample of topsoil. This was poorly done by several candidates. They were expected to state that *the soil would be weighed to get the initial mass then allowed to dry in a warm oven then reweighed and dried repeatedly until a constant weight is obtained. The water holding capacity is determined by subtracting the final mass from the original mass*. An alternative method could be to *put dry soil sample in a filter paper lined funnel inserted in a measuring cylinder or flask then pour a known volume of water over the soil and allow time to drain completely by checking the volume drained until it is constant for two or more consecutive readings. The water holding capacity can then be calculated by subtracting the volume of water collected from that poured onto the soil*.

Part (c) (ii) was well done as most candidates were able to state that *soil is important to living organisms as it provides anchorage, air, water, minerals/nutrients to aid plant growth or soil is a habitat for many organisms*.

Part (d) was well done by candidates familiar with a tullgren funnel. Most candidates recognized that the light bulb provides a stimulus — light/heat — to drive the soil organisms out of the soil but only a few knew that the alcohol functions to kill or preserve the invertebrates as required in responding to Part (d) (ii).

Several candidates were awarded marks for stating that bacteria and fungi function as decomposers but few were able to explain that *they produce enzymes that break down complex organic matter/compounds found in dead and decaying matter to simple organic nutrients that other organisms can use for their own purposes*. Some candidates stated the role of the bacteria associated with the carbon and nitrogen cycles but did not make the link to the cycling of the nutrients. A common misconception was that bacteria and fungi feed (in the same way as other heterotrophs) on dead and decaying organisms. Although the decomposers get their food/energy from detritus, they differ from scavengers and detritivores in that they secrete enzymes on the decayed material converting it to nutrients that are available to other organisms within the ecosystem.

### Question 2

This question examined candidates' knowledge of photosynthesis and digestion of starch in humans (SO B2.2, 2.4, 2.7 and 2.8). Candidate performance on this question was satisfactory. While candidates were able to access marks across the full range of the question, their performance showed a mean of 8 out of 15.

Most candidates were able to state that chlorophyll, light and constant temperature are conditions not shown in an equation summarizing photosynthesis as required in Part (a) (i). However, although many candidates recognized that oxygen (O<sub>2</sub>) was the gas given off in the process, fewer knew that the reactant that produced the oxygen was water (H<sub>2</sub>O).

Part (a) (iii) asked candidates to explain two ways plants use the glucose produced. This was challenging for many candidates. Candidates were expected to state that *the glucose is converted to sucrose/transported as sucrose from the leaves to parts of the plant that require glucose/energy for example, growing points*. Marks were also awarded for saying that *it is used in respiration to provide energy or for making cellulose/cell walls or stored in the form of sucrose in fruits or starch in seeds, leaves, stems or roots*.

Part (a) (iv) was well done as most candidates were able to state that *environmental factors such as temperature, carbon dioxide availability, sunlight intensity, the availability of water/rain/moisture, humidity or wind may affect the rate of photosynthesis*.

Very few candidates were able to accurately explain how the body converts starch in cassava to glucose. Candidates were expected to explain that *in the mouth starch is broken down by salivary amylase to maltose then later in the small intestine/duodenum, pancreatic amylase and maltase further break down starch and maltose respectively to produce glucose*. A common misconception was that digestion of starch continues in the stomach.

### Question 3

This question tested candidates' knowledge of the functions of the parts of the female human reproductive system, zygote formation, mitosis, meiosis, cell specialization and physiological diseases (SO B9.2, 9.4, and C1.5, 2.2, 2.4). Performance on this question was unsatisfactory. Candidates were able to score across the range zero to 15 but the mean was 6.

In Part (a), candidates were given a diagram illustrating the structure of the human female reproductive system and asked to label the organs to show the following: (i) where female gametes (ova) are made; (ii) where fertilization would normally occur and (iii) where implantation of a fertilized gamete would normally occur. Most candidates were awarded marks for labelling the ovaries (i) but some candidates did not correctly identify the oviduct/fallopian tube as (ii) and the uterus wall for (iii). A common misconception was that fertilization normally occurs in the uterus. The term *fallopian tube* was frequently spelt incorrectly.

Many candidates were awarded full marks for their outline of the mechanism by which male and female gametes come together in the human reproductive system to form a zygote as required in Part (b). Several candidates did not get full marks because they did not mention that only one sperm penetrates or enters the ovum and genetic material combines or nuclei fuses forming a zygote. An example of a candidate's response which was awarded full marks was:

*After ejaculation in the vagina, sperm from the penis swim up the uterus to meet the ovum in the woman's fallopian tube. The sperm that reaches first will penetrate the ovum and their nuclei fuse to form a zygote. This is called fertilization.*

In Part (c) (i), several candidates were awarded the mark for correctly naming *meiosis* as the type of cell division by which female gametes are formed. However, several candidates were unable to get full marks for their description of two ways in which meiosis differs from mitosis. Several candidates were able to state that *meiosis results in the production of cells containing half the number of chromosomes (haploid number) found in the parent cell while mitosis results in cells containing the diploid number or the same number of chromosomes as in the parent cell*. Few candidates included differences such as *crossing over/exchange of alleles takes place during meiosis but none occurs in mitosis*; or that *cells produced from meiosis are genetically different from each other while those formed from mitosis are genetically identical*. Candidates who did not read the question carefully mentioned that more than one parent is required for meiosis while one parent is required for mitosis. These candidates were not awarded any marks as the question did not ask them to compare sexual with asexual reproduction.

In Part (d), candidates were told that embryonic stem cells are undifferentiated cells formed as the embryo grows and develops which are capable of differentiating into specialized cells of tissues and organs in the human body. Only a few candidates were able to suggest two reasons why cell specialization is important as required in Part (d) (i). Most candidates were awarded at least one mark for stating that specialized cells form tissue/organs which carry out specific functions in the human body. Other expected responses that were awarded marks were: *specialized cells/tissues/organs can carry out different life processes simultaneously; body (processes) works more efficiently*. Good candidates were able to correctly suggest that *physiological diseases are caused by defective cells/organs/systems so embryonic stem cells could be used to produce specialized cells to produce organs that can replace the defective one(s)*. Another response that would be awarded marks is that stem cells replicate quickly.

#### Question 4

This question assessed candidates' knowledge of important genetic terms and their ability to use a genetic diagram to illustrate inheritance of albinism and identify sources of variation (SO B7.11, C1.1, 2.7, 2.8 and 3.1). Performance was unsatisfactory with a mean of 6 of the 15 marks.

Part (a) was the most challenging part of the question for most candidates. They were required to distinguish between genetic terms that are closely related but whose meanings are easily confused. Some candidates were able to get one of the two marks allotted if they gave correct examples to explain their answers.

Very few candidates correctly identified a gene as *the unit of inheritance* or more precisely as *a part of a chromosome/section of DNA that codes for the production of a specific protein*. An allele on the other hand is one of the alternative forms of a gene. The following are some common misconceptions/errors repeatedly observed in the responses of several candidates that teachers should seek to clarify in teaching the terms:

- An allele is an organism which codes for a gene.
- A gene is an organism on a chromosome which is responsible for various appearances and conditions in the body.
- A gene is a special protein or a symbol using capital and common letters.
- A gene is the genetic make-up of an organism.

Few candidates were able to distinguish between the terms dominant and recessive. *Dominant refers to the allele expressed in the phenotype or physical appearance of the organism even in the presence of another allele while recessive refers to the allele not expressed in the presence of another allele and/or only expressed in the phenotype if the dominant allele is not present*. A common misconception was that the dominant allele is stronger/superior or more popular while the recessive is weak or inferior.

Many candidates were able to explain that heterozygous means having two different alleles for a gene present and gave appropriate examples; but only a few were able to explain that homozygous means having two identical alleles for a gene present in the cell.

Part (b) required that candidates use a genetic diagram to show how a couple with normal pigmentation may produce an albino child, using the symbol 'A' to represent the normal allele and 'a' for the albino allele. This was fairly well done by most candidates; however, those who did not get full marks did not include, for example, *Parent phenotype*, *Parent genotype* to 'label' each step which would show a clear understanding of how the correct answer was arrived at. The expected candidate response was:

*In order for a couple to have an albino child both parents must be heterozygous/carriers of the albino allele.*

*The Genetic diagram showing how a couple with normal pigmentation may produce an albino child:  
A represents Normal allele; a represents the albino allele*

<i>Parents' phenotypes:</i>	<i>Normal</i>	<i>x</i>	<i>Normal</i>
<i>Parents' genotypes:</i>	<i>Aa</i>	<i>x</i>	<i>Aa</i>
<i>Gametes:</i>	<i>A a</i>	<i>x</i>	<i>A a</i>

*Fertilization cross:*

	<i>A</i>	<i>A</i>
<i>A</i>	<i>AA</i>	<i>Aa</i>
<i>A</i>	<i>Aa</i>	<i>Aa</i>

*F1 genotypes                    AA: Aa, Aa : aa*  
*F1 phenotypes                3 Normal                    : 1 Albino*

Mentioning that there was a 25 per cent or 1 in 4 chance of the couple having an albino child would also allow them to gain one mark.

Most candidates were awarded full marks for suggesting precautions that albino persons living in the Caribbean should take when going outdoors such as *wearing sunscreen*, wearing hats or using umbrellas or wearing protective clothing as required in Part (b) (ii).

Good candidates were usually able to get full marks for naming at least two of the three suggestions required in Part (c) to explain how variation in skin colour occurs among members of a population. The expected responses that were awarded marks include: *continuous variation of alleles of skin colour gene*, *interracial mating*, *mutation in skin colour gene* and *exposure to varying degrees of sunlight/tanning*. Other responses such as *skin disease* and *skin bleaching* were also awarded marks.

### Question 5

This question tested candidates' knowledge of the structure of the eye and how it functions to allow one to see an object as well as the physiological effects of alcohol consumption on homeostasis (SO B7.8 and 7.9). Performance on this question was also unsatisfactory even though candidates were able to score across the range of marks, zero to 15. The mean was 6.

Part (a) asked candidates to make a labelled diagram of a horizontal section through the human eye and describe how the eye enables us to see. Several candidates were able to produce an accurate representation of the eye with important structures such as the cornea, iris, lens, suspensory ligaments/ciliary muscles, retina, fovea and optic nerve in the correct position along with the correct labels. Some candidates labelled parts that were not directly involved in 'seeing' such as the eyelashes. Drawings were often out of proportion and done with sketchy lines. Many candidates were, however, unable to describe how the eye enables us to see. Candidates were expected to describe how *light from an object enters the eye through the cornea/pupil, then it is refracted by the lens onto the retina. The rods and cones in the retina detect the light/stimulus and*



*sends impulses along the optic nerve to the brain. The brain interprets the image allowing us to see it. Many attempted instead to explain how the iris controls the amount of light entering the eye or how the eye accommodates to focus on far and near objects.*

Part (b) was especially problematic as many candidates were familiar with the effects of alcohol but were unable to link these effects to the inability of the person to maintain a constant internal environment (homeostasis). Most candidates were able to list effects of alcohol abuse on the human body's ability to respond to stimuli such as: *alcohol slows the person's reaction time to stimuli because it is a depressant; it destroys/shrinks brain and nerve cells/speeds up loss or destruction of these cells; it decreases awareness of the person, causes blurred vision so the person cannot see objects clearly to respond to them.* Many candidates were able to gain marks for stating that *homeostasis is the maintenance of a constant internal environment* but only a few candidates were able to link the fact that *alcohol abuse can lead to liver damage which may lead to an inability of the body to deal with toxins and excess nutrients or chemicals as well as cause the kidneys to produce urine more often. Alcohol abuse also suppresses the production of the antidiuretic hormone (ADH) and this would promote dehydration of cells which cause them to be out of balance.*

### Question 6

This question assessed candidates' knowledge of the definition of a species, the process of speciation, the role of natural selection in biological evolution as evidenced by the peppered moth and the development of antibiotic resistance (SO C4.1, 4.2 and 5.1). Performance was very poor with a mean of 3 even though candidates were able to score across the full range of marks.

In Part (a), candidates were first asked to name three characteristics which distinguish a biological species. Very few candidates were able to explain that *a biological species is differentiated from another if they are unable to interbreed and produce fertile offspring. Members of the same species are able to interbreed and produce fertile offspring. They also share a common ancestry and have similar genes.* Stating that they have similar anatomical, biochemical and morphological features (morphological species concept) were also awarded marks. A common misconception was that the characteristics of living organisms (for example, respire, feed, grow, excrete and reproduce) can be used as the basis for distinguishing one species from another. Some answered the question by listing morphological features used in classifying organisms at the higher order of classification such as wings, hair, and body segments.

Candidates were also asked to name three factors that lead to the formation of a new species. Candidates were expected to describe factors that result in any change in genotype that results in infertility, that is, reproductive isolation. Factors included *geographic isolation caused by formation of rivers or mountains; ecological factors such as occupying different niches; behavioural factors which result in reproductive isolation such as being nocturnal versus being diurnal; having different mating habits or being fertile at different times of the year. Factors that could result in an individual no longer being able to interbreed with the original population such as mutation, genetic engineering and artificial selection* were also awarded marks.

Candidates' ability to account for the increase in the number of the dark form of the peppered moth, *Biston betularia* in the postindustrial era was tested in Part (b). They were expected to explain that *post-industrialization, the speckled (light coloured) form was poorly camouflaged and more likely to be eaten by birds since the soot from factories during industrialization caused the tree trunks to be blackened so that the dark form was now well camouflaged. The dark form now had the selective advantage (which belonged to the pale speckled form when the tree trunks were lichen covered). Preindustrialization, both variants — the speckled form and the black form — existed but the speckled form was well camouflaged on the lichen covered trees, so less selection pressure was exerted by bird predation and they therefore existed in higher numbers.* A common misconception was that the soot caused the speckled form to mutate/adapt and become dark in spite of the question stating that both variants existed. This example merely demonstrates one of the ways in which natural selection operates, that is, due to camouflage.

Part (c) asked candidates to use the theory of natural selection to explain antibiotic resistance. A few candidates were able to describe the theory of natural selection as an explanation that *organisms that are*

*well adapted or have characteristics that help them to survive in their environment will survive (be selected) to pass on their characteristics to their offspring. Candidates were expected to state that some bacteria in the population already have resistance to antibiotics as a result of mutation, while some do not as there is variation in the population. The less resistant (susceptible) ones are killed on exposure to the antibiotic while the resistant ones survive. The survivors reproduce and pass on the resistant genes to their offspring. The survivors will multiply rapidly because of reduced competition from nonresistant forms. Eventually most survivors will be the ones that are resistant to the antibiotic.*

Some candidates confused antibiotic resistance with the immune response in humans against diseases caused by pathogens. The term antibiotic was often confused with antibodies. Another misconception was that the human (not the bacteria) developed the resistance.

Teachers could use this example of natural selection to find out what students understand about the nature of antibiotics. The difference between the use of the term *resistance* in the context of immunity and its use in the context of bacterial resistance to antibiotics should be explained.

### **Paper 032 – Alternative to the School-Based Assessment (SBA)**

This paper assessed most of the practical skills required of Biology students. Candidates continue to display weak practical skills especially in aspects of planning and designing including manipulating apparatus, describing methods of experiments, identifying limitations and in drawing conclusions from data. These observations indicate that *in developing practical skills* private candidates *need to be exposed to actual experimenting and investigating scientific phenomena, discussions, explanations and rationalizing of procedures and outcomes* so that they become capable of developing and manipulating experiments and experimental data.

#### Question 1

This question tested candidates' practical skills in measuring and recording lengths of potato cylinders immersed in different concentrations of sucrose as well as candidates' ability to explain the results of the experiment involving diffusion; identifying precautions and limitations; indicating how the experiment could be modified to assess reliability of the results and demonstrate knowledge of growth (SO B1.6, 8.1). Performance on the question was poor as the mean was 12 out of 30 marks. Candidates were able to score a maximum of 27 of the maximum 30 marks allotted to this question.

Candidates were provided with 25cm<sup>3</sup> of distilled water and similar volumes of sucrose solutions at concentrations ranging from 1 per cent to 20 per cent, along with five potato cylinders, and instructed to investigate the movement of water in and out of the plant tissue. In Part (a) (i), they were required to measure and record in the table provided, the original, final difference and percentage difference in length of each potato cylinder immersed in each liquid for 30 minutes. They were also asked to observe and record the texture. This was well done by most candidates but a few did not pay attention to the unit of measurement (cm) to be used in measuring the lengths. Some did not use the terms given for describing the texture and instead used incorrect terms such as 'rough' and 'smooth' instead of *flaccid/soft; firm/turgid*.

In Part (b), candidates were asked to calculate and record the difference in length for each of the potato cylinders. A few candidates did not understand that this meant subtracting the original from the final length. Similarly the percentage difference (or change) in length was to be calculated in Part (c) by *dividing the difference in length by the original length and multiplying by 100 to convert to a percentage*. An alternate method is to *divide the original length by the final length then multiply by 100 to convert to a percentage then subtract 100 from the result to get the percentage difference (or change) in length*.

The values for the percentage difference in length were to be used to draw a histogram in Part (d). Several candidates failed to get full marks because they did not use appropriate legends to label both axes. Candidates were awarded marks if the number of beaker or concentration of sucrose solution was put on the *x*-axis while percentage difference in length (%) was placed on the *y*-axis. Some candidates plotted a line graph instead of bars relating to each potato cylinder/beaker number as discrete units and were awarded no marks.

Part (e) asked candidates to explain the results of the experiment with respect to the length and texture of the potato. Several candidates did not explain the results but instead described the information already presented in the table. Some candidates only stated that *osmosis occurred* but failed to explain that *an increase in length was observed where water moved into the cells of the potato tissue by osmosis from the distilled water and/or lower concentrations of sucrose, causing the cells to swell/increase in size; while a decrease in size was caused by water molecules leaving the potato cells/tissue and moving into the sucrose solution, causing them to shrink*. Very few candidates mentioned that *no change in the length/no net movement of water occurred if the concentration of the potato cells/tissue was the same as the solution*.

It was observed that some candidates did not use biological jargon in describing the movement of water and instead said that ‘the sucrose solution draws out the water from the tissue’. Some candidates had the misconception that osmosis is the movement of water molecules from a region of low water concentration to a region of high concentration through a semipermeable membrane. Another misconception was that the sucrose molecules were able to move into the potato cells/tissue.

The firm/turgid texture of the potato cylinder was due to the water molecules entering the potato cells/tissue and causing the cell contents to press against the cell wall. In the case of high concentrations of sucrose solution, the texture was flaccid because water molecules moved out of the cells and the cell contents shrunk away from the cell wall/were no longer pressing against the cell wall.

Part (f) was well known as most candidates responded that the potato skin had to be removed because it was impermeable to water/would prevent or slow the movement of water into or out of the potato tissue. Candidates who stated that it was removed because it was tough were awarded no marks.

Part (g) required that candidates state two precautions and one limitation of the experiment. Most candidates were awarded marks for listing precautions such as *ensuring that the potato cylinders have the same dimensions; ensuring that the cylinders are immersed for an equal amount of time; ensuring that the cylinders are immersed in the same volume of water/solution or that other factors such as the temperature of the liquids are kept constant*. Few candidates were able to state that *the time allowed for the experiment was a limitation*. Candidates who stated that *the volume of solution/water was a limitation because the cylinders were not fully immersed* were awarded marks.

In Part (h), most candidates were able to correctly state that other measurements such as *the mass/weight of the cylinders, the diameter/width/circumference of the cylinders or the volume of water/sucrose solution before and after 30 minutes of immersion of the cylinders could be used instead of length in the experiment*.

Part (h) (i) was also well done as most candidates suggested *repeating the experiment using more than one potato cylinder in each liquid*. Good candidates also correctly added that *the average length could then be calculated to get reliable results*. Some candidates mentioned that *increasing the amount of time allowed for the experiment or using more water/solution would increase the reliability of the results* and were awarded marks.

Only a few candidates were able to explain that *the change in length is not considered growth because growth is a permanent increase in the length/width/dry matter of the tissue, however, what occurred was only a temporary increase in size due to intake of water*.

## Question 2

This question examined candidates’ knowledge of gaseous exchange and their ability to produce biological drawings of a leaf. Their ability to present data using appropriate graphs and use data to arrive at correct conclusions was also assessed. Performance was poor with candidates achieving a maximum of 14 of the 17 possible marks allotted and a mean score of 6 marks.

Good candidates were able to identify *large surface area* and *thin walls* as features common to the three gaseous exchange surfaces in Part (a). Candidates who said *associated with transport vessels to carry the gases to and from the surface* or *moisture present* were also awarded a mark for their responses.

Most candidates were able to score one mark in Part (b) for identifying *oxygen* and *carbon dioxide* as the gases exchanged but very few candidates were able to state that the process was *diffusion* and explain that *oxygen is used by the cell in respiration or that carbon dioxide is produced during respiration or carbon dioxide is used by the leaf for photosynthesis*.

In Part (c), candidates were asked to make a labelled drawing of the leaf in Figure 1 that was twice the size shown. Although most candidates were able to produce a representative drawing with respect to the shape and venation of the leaf, most drawings observed did not have the correct proportions of the veins, petiole/stalk compared to the lamina and the magnification usually exceeded 'x2' when measured. Many candidates were also not familiar with the names of the external structures of the leaf. The *lamina/blade* was often labelled 'leaf' and the *petiole/stalk* was often labelled 'stem'. The *margin, apex, axil, midrib* were often not included among the labels. It was also evident that most candidates did not use clean continuous lines to produce the drawings.

In Part (d), candidates were provided with data collected from an investigation of the effect of exercise on the rate of breathing in smokers and non-smokers over a nine-minute period. Part (d) (i) required that they plot a graph of the data. This was well done by most candidates. Accurate line graphs were plotted in most instances with time in minutes on the X axis and number of breaths per minute on the Y axis. A key or labels were usually used to distinguish data from smokers from the data for non-smokers. Very few candidates were able to indicate that variables such as *age, sex, body size, fitness/health status, type of exercise or duration/intensity of exercise should be kept constant/be the same for all participants in the investigation* as required in Part (d) (ii). Most candidates were, however, able to conclude that smokers have higher breathing rates than non-smokers. Candidates who indicated that the *breathing rate of smokers takes a longer time to return to resting rates* than that of non-smokers were also awarded marks.

### Question 3

This question assessed candidates' ability to use a choice chamber to investigate the response of invertebrates to a stimulus, as well as write a suitable hypothesis and construct a table to record observations and write a conclusion, and design an investigation to investigate the response of woodlice to light. Candidates' performance was also poor with a mean of 5 of the 13 marks allotted and a maximum of 12 marks achieved.

Candidates were given a diagram of a choice chamber with wet and dry conditions connected by a connecting platform in Part (a) and asked to write a suitable hypothesis for the investigation. Some candidates were able to state a testable hypothesis such as *woodlice prefer damp/wet/moist conditions to dry ones*. Candidates who wrote an aim were not awarded marks.

Part (b), which required that candidates use a labelled line on the diagram to indicate where the woodlice should be placed at the start of the experiment, was well done. Most candidates recognized that they should be placed in the middle of the connecting passageway.

In responding to Part (c), most candidates were also able to name *light* and *temperature* as two factors that should be kept constant during the investigation.

In Part (d), candidates were given a diagram showing the distribution of woodlice in wet and dry conditions and required to construct a suitable table to record the observations shown in the diagram showing the distribution of woodlice in Part (d) (i). Several candidates were awarded marks for giving a suitable title and presenting accurate data. However, some did not gain full marks because they did not use appropriate headings such as conditions: wet and dry and/or number of woodlice. In Part (d) (ii), most candidates were able to conclude that *woodlice prefer moist conditions* but only a few were able to explain that *the response is useful to prevent desiccation or drying out by the woodlice because of their small surface area to volume ratio or to facilitate the exchange of gases*. Most candidates' explanation was related to avoidance of predation which is incorrect.

Only a few candidates were able to describe how they would cover half of the choice chamber with foil/dark cloth and leave the other half exposed to light. Some mentioned that wet or dry conditions would remain constant.

### **Paper 03 – School-Based Assessment**

The School-Based Assessment (SBA) was moderated on site by experienced teachers across the region for the first time. The new CXC CSEC Biology syllabus (pages 63–76) provides guidelines for the assessment of students' practical skills that should be given keen attention, especially by new teachers. The assessment criteria outlined in the syllabus should be used as a guide to facilitate students' development of the respective practical skills as well as to prepare mark schemes by teachers at the respective centres preparing candidates for examination. The examining committee would also like to once again reiterate that *laboratory activities should be used to support the theoretical content and not be treated as a separate activity*.

Practical skills were generally observed to be weak. The skill of Observation, Recording and Reporting (ORR) was generally well done. Drawing (Dr), Manipulation and Measurement (MM), Analysis and Interpretation (AI) and Planning and Designing (PD) continue to present students with the most difficulty.

The following is a list of criteria which teachers should follow in marking SBA activities:

- Marks should be awarded for each skill separately.
- Students should be given as much detailed feedback as possible to facilitate learning.
- Teachers are once again reminded that body fluids such as saliva, blood and urine are not to be used for practical work. These can be sources of infection and may have serious legal implications should a student become infected while conducting practical work.

The examining committee would also like to recommend that there be greater cooperation among teachers of similar subjects at the same centre and mentoring of new teachers, to ensure that consistency in standards is maintained.

A review of previous schools reports will provide additional suggestions for developing practical skills. Further suggestions are reiterated in this report and *each* teacher is alerted to the specific strengths and weaknesses displayed by their students in the Moderation Feedback Form sent to schools from CXC, after moderation. Improvement of students' practical skills will have a direct influence on overall performance in the Biology examination, since certain questions, notably Question 1 on Paper 02, are based on the knowledge and application of these practical skills.

#### **Specific Comments on the Assessment of Skills**

The following information is to assist especially new teachers of Biology in interpreting the information given on the CXC Moderation Feedback Report.

The number of times a skill is assessed is considered sufficient if assessed a minimum of four times.

#### **Observation, Recording, Reporting (ORR)**

Students should be encouraged to give careful attention to grammar, quality of expression and to provide as many details as possible when reporting their procedures and observations, as science students need to appreciate the importance of clarity in explaining their results. Where possible, students should also be encouraged to repeat procedures and give average results to improve the reliability of their results.

The tables and graphs should be clear and provide adequate details which allow for a clear description of results and discussion of the experiment. The examining committee recommends that teachers give more activities where students construct their own tables and graphs using their results. This will allow them the opportunity to develop these skills.

When using tables, teachers should remind students that the title should be written before the table using capital letters, the table must be enclosed and appropriate row and column headings should be given.

**Example:**

TABLE 1: FROG POPULATION OBSERVED FROM OCTOBER 1997 TO OCTOBER 2004

Year	Number of frogs
2004	5
2001	110
1997	125

When using graphs, the title should be written below the graph and underlined; axes should be labelled, with units stated and a key should be presented if necessary.

If calculations are required, all necessary calculations should be shown and these should be done and presented neatly and in an organized fashion. Units should also be included where necessary.

Where drawings are used in reporting observations, they should meet standard SBA drawing criteria although the skill is not being assessed.

### Drawing (Dr)

Biological drawings do not have to be works of art, but they should meet the criteria for accuracy, proportion, clarity, labelling and magnification. Teachers should ensure that students are given several opportunities to practise and develop drawing skills.

It is a requirement that drawings must be practised from actual specimens and *not from textbooks*. Specimen may include drawings of *flowers, fruits, storage organs and bones*. Additional examples may be included in practical books. However, *microscope drawings, models and apparatus should not be used for SBA assessment*. Drawings of cells while useful for teaching should not be assessed at this level but if taught, the calculation of magnification should also be emphasized. Similarly, dissections may help students to understand structures such as the digestive system but they are too complex to be drawn accurately at this level. These difficult drawings do not provide a fair test of ability at this level.

Table 1 is a list of ‘Do’s and ‘Don’ts applicable to SBA biological drawings

**TABLE 1  
DO’S AND DON’TS OF BIOLOGICAL DRAWINGS**

Do’s	Don’t s
<ul style="list-style-type: none"> <li>• Use pencils for all drawing activities – drawing, label lines, labels.</li> <li>• Use drawings of actual biological specimen (not diagrams, models or textbook drawings); ensure for assessment there are drawings of flowers, fruit, seeds and bones.</li> <li>• Let the size of drawings be at least half page.</li> <li>• As far as possible, have label lines and labels positioned at right side of drawing.</li> <li>• Let all label lines end at the same vertical plane.</li> <li>• Let label lines be drawn parallel to the page top/bottom.</li> <li>• Ensure label lines end on part being made</li> <li>• Write title using capital letters.</li> <li>• In title, use word <i>drawing</i> and not ‘diagram’.</li> <li>• Position title under the drawing and indicate the actual name of the specimen (for example, cervical vertebrae of a goat, mango leaf, hibiscus flower) and the view drawn.</li> <li>• Underline the title.</li> <li>• Include the magnification and state, where appropriate, actual length and width of specimen as well as place ‘x’ in front of the magnification.</li> <li>• Write magnification to one decimal place.</li> <li>• Use a key to explain symbols, where appropriate, for example, stippling/cross hatching.</li> </ul>	<ul style="list-style-type: none"> <li>• No arrow heads.</li> <li>• No crossing of label lines.</li> <li>• No dots or dashes.</li> <li>• Do not join letters of words for label or title.</li> </ul>

Label lines should be drawn with a ruler and as much as possible, labels should be written in script (not capitals) so that they can be easily read. Annotations should give the functions and descriptions of the structure where appropriate. Annotations that accompany drawings should be as brief as possible and clearly and neatly written.

The examining committee also encourages teachers to ensure that standard drawing criteria are applied whenever drawings are required in lab activities, especially when reporting observations and/or illustrating biological processes, for example, germination, regardless of whether DR skills are to be assessed or not. This should help students appreciate the importance of the skill.

Teachers should also ensure that students draw on plain paper and then neatly insert drawings into lab books, if the books are not designed with plain sheets of paper for drawing. Distinguishing features and labelling lines are oftentimes unclear when drawings are done on ruled sheets of paper.

### Analysis and Interpretation (AI)

This skill continues to present problems for the majority of students. Many teachers continue to use questions to stimulate discussion. This device is good for helping students to develop their AI skills. However, this should not be the *only* means of assessment. These questions must guide students to provide the required background information, give explanations for the results, draw conclusions and show an awareness of possible limitations. The information provided in this way should then be written up as a paragraph of continuous prose as is normally done for the discussion/conclusion. In many cases, students seem to have learnt a formula for writing up the discussion but showed no real understanding of how to interpret their own results. As a learning strategy, teachers may ask their students to orally explain the results to obtain a clearer view of their understanding and to help them develop their analytical skills.

The marking criteria should also include precautions, controls, sources of error and limitations if appropriate.

The use of controls should be emphasized in discussions as they are a point of comparison for the experimental set-up in which a particular variable has been omitted. This comparison should be included in the discussion as it is the key to drawing the conclusion. Conclusions should relate directly to the aim of the investigation. Students should also be reminded to discuss at least one limitation of the investigation. It is important for them to recognize that the conditions present in a school laboratory are rarely ideal.

The processes involved in demonstrating the AI skill are reiterated here:

- Background information may be written in the *Discussion*, or in the introduction section.
- Background information for the experiment must be related to the theory.
- Discussion should be an analysis or interpretation of the recorded experimental results. Discussion must not simply answer posed questions for AI:
  - a. Questions may be used to guide students but answers must be written in paragraph format (without the questions or written comprehension style).
  - b. Questions should not to be included in the lab report.
- The conclusion must be based on the aim. (It is a brief answer to the aim.)
- Limitation(s) should be included among the AI marking criteria as very important to labs.
- Identifying source(s) of error and precaution(s) is necessary as is knowing that these are both different from each other and from limitation(s).
- All components of AI (background knowledge, explanation of results, limitations and conclusion should be included in the mark scheme for the skill).

The examining committee is again reminding teachers that food tests *on their own* are not appropriate for assessing AI. Simple investigations can be designed in which food tests are used. For example, students can be given unknown mixtures and asked to find out which food would be most suitable for an infant. Food tests can also be used to determine the presence of a particular food before and after digestion by an enzyme. These types of exercises will allow students to develop the necessary skills. Knowledge of the food tests and the nutritional requirements can then provide the background information on which students will base their conclusions.

### Manipulation and Measurement (MM)

The examining committee recommends that teachers expose students to as wide a range of apparatus and their use in collecting data as is possible. This would help to ensure students' manipulation skills develop and allow for a more fair assessment of students' competence in MM.

### Planning and Designing (PD)

The examining committee continues to emphasize the importance of using examples from students' local environment as this will help them better appreciate how they can apply their biological knowledge and



practical skills to solve problems they frequently encounter. Teachers are reminded that it is inappropriate to have students copy procedures from textbooks and reproduce them verbatim for assessing students' PD skill.

It is also important that development of the skill start with the commencement of the teaching of the syllabus. In many cases it was obvious that practical activities targeting the development of the Planning and Designing skill was among the last set of activities in which the students engaged prior to the examination. Figure 1 is an example of how a planning and designing activity might be effectively developed.

**Example:**

This Planning and Designing activity submitted by one centre was based on the observation that *A boy notices that all the trees around his yard except the grapefruit tree were infested with 'duck' ants.* The students were required to plan and design an experiment to determine what was responsible for the difference in infestation. An example of an appropriate hypothesis and a relevant aim for investigating the hypothesis was:

***Hypothesis:** 'Duck' ants do not feed on grapefruit trees because the leaves contain a chemical that repels the ants.*

***Aim:** To find out which plant leaves 'duck' ants feed on  
(The aim of the subsequent investigation could be: To determine the presence of chemical X in different leaves.)*

There was a clear description of the materials and method. Students planned to use different leaves to see if the 'duck' ants would respond as they do to the grapefruit leaves. The 'duck' ants would then be placed in labelled containers containing the same number and sizes of leaves taken from a grapefruit tree. A container with no grapefruit leaves was an appropriate control. The measurable variable would be the number of 'duck' ants that either leave or remain in each dish. Results would then be tabulated and subsequently discussed.

As stated by the students, one limitation may be that *the chemical in the leaves that cause the effect on the 'duck' ants may be affected by the extraction.* Appropriate marks were awarded for the various aspects of the experiment.

**Figure 1.** Example of a Good Planning and Designing Activity

**CARIBBEAN EXAMINATIONS COUNCIL**

**REPORT ON CANDIDATES' WORK IN THE  
CARIBBEAN SECONDARY EDUCATION CERTIFICATE® EXAMINATION**

**JANUARY 2016**

**BIOLOGY  
GENERAL PROFICIENCY EXAMINATION**

**Copyright © 2016 Caribbean Examinations Council  
St Michael, Barbados  
All rights reserved.**

## GENERAL COMMENTS

The January 2016 examination in Biology at the General Proficiency level was the 50th sitting of this subject conducted by the Caribbean Examinations Council. Biology continues to be offered at both the January and June sittings of the examinations. The examination comprises three papers: Paper 01 — Multiple Choice; Paper 02 — Structured/Extended Essay; and Paper 032 — Alternative to School-Based Assessment (offered only to private candidates).

The overall performance of candidates this year was below expectations. Several candidates demonstrated below average knowledge of fundamental biological concepts and principles relating to growth, the role of guard cells in transpiration, digestion and genetics. Topics such as genetic engineering technology, natural and artificial selection also presented major challenges for many candidates.

More time needs to be devoted to practising how to interpret and answer questions clearly and concisely and not just to memorizing biological processes. The poor spelling of biological terms also continues to be problematic and needs to be given attention when preparing for the examinations.

Greater emphasis also needs to be placed on developing practical skills and candidates' ability to demonstrate these skills in responding to questions on Paper 032. Activities related to drawing and planning and design skills should be given particular attention. Candidates generally displayed limited understanding of how to achieve accurate and reliable results, and demonstrated particular weakness in stating hypotheses, describing appropriate procedures for experiments and identifying limitations of experimental procedures. Private candidates should seek to enhance their practical skills by making use of the relevant simulation laboratory experiments, several of which are accessible via the internet, if they are unable to get practical experience under the supervision of a classroom teacher.

Candidates and teachers are being asked to note the strengths and areas of weakness in candidates' performance in this sitting of the examination and to pay careful attention to the following recommendations made by the examining committee, reiterated in this, as well as in previous reports, in order to enhance the quality of their performance in these examinations.

## DETAILED COMMENTS

### Paper 01 – Multiple Choice

Paper 01 consisted of 60 multiple-choice items. Performance on this paper was disappointing compared with that in previous years. Some of the topics that candidates found problematic were:

- Abiotic factors
- The structure of a prokaryote cell
- Transport in plants
- Transpiration
- Respiration by yeast cells
- Names of major blood vessels
- Functions of parts of the brain
- Eye defects
- Growth movement in plants
- Germination
- The hormones of the menstrual cycle
- Sexual reproduction in flowering plants
- Cell division by mitosis vs meiosis
- Sources of genetic variation
- Definition of alleles, genes
- Natural selection
- Artificial selection
- Definition of species
- Speciation
- Genetic engineering technology

### Paper 02 – Structured and Extended Essays

Paper 02 consisted of six compulsory questions, three of which were in the structured response format and three in the extended essay format. Most candidates were not able to score marks across the full range for all questions.

#### Question 1

This question dealt with data collected from an investigation of growth of plants in light and dark conditions compared with changes in length of a human baby over the same time period. It tested specific objectives (SO) B2.2, 7.2, 7.4 and 9.1, as well as all three profile skill areas identified in the

Biology syllabus – Knowledge/Comprehension, Use of Knowledge and Experimental Skills. Candidates were able to access marks ranging from 1 to 21 of the 25 marks. The mean mark was 8.

Part (a) required candidates to plot height data, presented in a table, of a plant grown in sunlight and that of one grown in darkness, given in five-day intervals over a thirty-day period. Candidates were expected to plot the data given for *both plants on the same graph* and use a key or labels to distinguish between the plots, but this was often not done. Several candidates plotted two separate graphs and were not awarded marks. If an appropriate scale was not used to plot their graph, many candidates lost marks as this sometimes affected their ability to plot the values accurately. Candidates were also not awarded marks if the axes were not correctly labelled using appropriate legend and if anything but a *line graph* was drawn.

Part (b) (i) asked candidates to describe the pattern of growth obtained for each plant. They were expected to state at least two trends observed in relation to the growth pattern of each plant. *The plant grown in the light grew slowly between Days 5 and 10, then rapidly between Days 15 and 30, while the one grown in the dark grew rapidly between Days 5 and 15 then slowed/stopped/lost height after Day 20.* Very few candidates were awarded the two marks because they sought to explain the trends observed rather than describe the patterns as required. Some were only able to earn one mark if they mentioned one trend for each plant, or if they did not refer to the time period/days within which the trends were observed and just said the plant growing in the light increased rapidly in height while the one in the dark grew more slowly. Part (b) (ii) was well done as most candidates were able to explain that *the plant grown in the light was able to photosynthesize/make adequate food to support growth/cell division while that grown in the dark was not able to photosynthesize, and therefore used up its limited food stored/reserved for growth, so after a while it stopped growing.*

Part (c) was poorly done by candidates who did not know that growth is a *permanent* increase in the *mass* of an organism.

In Part (d), candidates were asked to suggest why measurements of length taken for plants are incomplete unlike the measurements taken for a baby. They were expected to state that *when measuring the height of the plant, the roots (which are also growing) are not included in the measurement while the length of the entire body of the human baby is measured.*

Part (e) required that candidates suggest two ways in which the experiment could be refined/modified to obtain more accurate data for measuring growth. Candidates were expected to say that *replicates for each measurement could be taken and the average of the replicates used, or alternative methods such as counting leaves or the mass (dry or fresh) could be used instead of height/length as a measure of growth.* Many candidates also correctly indicated that ensuring that other environmental conditions such as the amount of water or carbon dioxide, which also contribute to the growth of the plant, should be kept the same in both light and dark conditions.

In Part (f), candidates were asked to describe one way in which the pattern of growth in plants differs from that in animals. Very few candidates were able to tell that *plants grow due to cell division in defined areas, such as the meristems in their shoots and roots or cambial tissue in stems, while animals grow due to cell division in almost all parts of their bodies*. Some candidates correctly indicated that *plant growth is seasonal and occurs throughout most of their lifetime in response to external environmental conditions such as light, while animals have stages in their lifetime where growth occurs in response to the availability of food*.

Part (g) (i) examined candidates' ability to describe an experiment that demonstrates the response of plants exposed to light from one side only. Most candidates were able to state that *the plant should be placed in an enclosed area/container with one opening to allow exposure to a light source from that side only*. Only a few candidates went further state that *the plant or plants should be allowed to remain for a specified period of time to allow growth to occur/the response to be shown*. Even fewer candidates mentioned *a control plant which is similar with respect to age and species, and exposed to similar conditions (such as the same amount of water given) but light is directed from all around the plant*.

In Part (g) (ii), candidates were expected to explain that *due to the number of trees in a forest, some plants may be exposed to a limited amount of light, so growing tall or bending allows them to capture as much light as possible for photosynthesis*.

Most candidates were awarded one mark for describing *that invertebrates such as earthworms move away from light, and plants do not* (Part (g) (iii)). Very few were able to explain that this is because they want to avoid desiccation or predation.

Several candidates were able to state that *light is used for vitamin D synthesis which is important for strengthening bones during human growth and development* (Part (h)).

## Question 2

This question examined candidates' understanding of the processes involved in the carbon cycle, the impact of deforestation, climate change and pollution by household waste (SO A5.1, 6.1, 6.4, 6.5; B 2.2 and 3.1). Performance on this question was satisfactory with candidates scoring across the full range of marks. The mean was 7.

In Part (a), most candidates were able to name the process labelled *A* as *photosynthesis*, *B* as *respiration* and *C* as *combustion* in order to complete the diagram of the carbon cycle given. It was observed that a few candidates labelled *B* incorrectly as *decomposition*. When decomposers respire they return carbon dioxide to the atmosphere so respiration was the response expected.

Part (b) was also well done as most candidates were able to write an accurate chemical and word equation to summarize the processes of photosynthesis and aerobic respiration. Candidates were expected to also include *light/solar energy as a condition for photosynthesis* in response to Part (b) (i),

and *energy/ATP as a product of respiration* in response to Part (b) (ii). Candidates are reminded that chemical equations should be balanced.

Part (c) examined candidates' knowledge of the outcome of the removal of trees by cutting and burning. Most candidates were able to outline that *burning the trees adds carbon dioxide to the air, and fewer trees means that less carbon dioxide will be removed from the air for photosynthesis*. Some candidates also mentioned that *the increased levels of carbon dioxide traps heat in the atmosphere, adding to global warming*. Several candidates also identified less rainfall, loss of habitat for tree dwelling organisms and increased soil erosion, as other outcomes associated with the removal of trees.

Most candidates were able to get at least one mark for suggesting two ways in which small island states such as those of the Caribbean may be affected by large-scale climate change. The range of expected responses included *rising sea levels contributing to frequent flooding and destruction of coastal ecosystems/beach erosion; loss of habitable land and reduced agricultural productivity caused by prolonged drought conditions or prolonged flooding*. A few candidates also correctly suggested that prolonged high temperatures and rainfall may increase mosquito breeding and hence increase transmission of mosquito-borne diseases, such as dengue fever and malaria.

Part (e) tested candidates' knowledge of the impact of waste disposal. In Part (e) (i), most candidates were able to give one of the two ways required in outlining how improper disposal of household waste contributes to land and water pollution. Expected responses include: *Soaps and other cleansing agents; toxic chemical waste like insecticides can affect the pH of the soil and kill useful soil organisms making the land less productive for agriculture; these chemicals seeping into underground water supply or rivers and making the water toxic for aquatic organisms; accumulation of waste on land or in gullies or rivers may clog up watercourses leading to flooding; the build-up of household waste on land can also encourage the breeding of disease vectors such as flies and rodents*. Most candidates said *disposing the waste at a landfill was environmentally friendly*, as required in Part (e) (ii). A few candidates also correctly suggested that *separating/reusing non-biodegradable waste and burying biodegradable/organic household waste (making compost bins) were environmentally friendly alternatives*.

### Question 3

This question tested candidates' knowledge and comprehension of the role of plant guard cells and the difference in behaviour of plant cells and animal cells in dilute solutions (SO B 1.1, 1.2, 1.3, 1.4, 1.6 and 2.3). Performance on this question was poor, with candidates scoring from 0 to 12 out of the allotted 15 marks. The mean was 4.

Part (a) tested candidates' knowledge of the structure and function of plant guard cells. In Part (a) (i), candidates were required to identify the structures labelled I to V on the plan diagram of the plant guard cells. This was poorly done by most candidates. Candidates were expected to label the structures as follows: *I – cell wall; II – cytoplasm; III – chloroplast; IV – stoma; V – nucleus*. In Part (a) (ii), they

were asked to state the functions of the structures labelled I and IV. This was well done by those candidates who correctly identified these structures in Part (i). *The cell wall protects the cell and helps it to maintain its shape. It also helps to protect the cell from the entry of pathogens. The stoma allows gases, namely oxygen and carbon dioxide, to move in and out of the leaf. It also allows the loss of water/transpiration.*

In Part (b), candidates were asked to draw an annotated diagram to show the appearance of the guard cells after the plant is watered in the early morning. Very few candidates were able to draw representative diagrams of the guard cells. They were expected to draw and annotate turgid guard cells with the cell membrane pressing against the cell wall and the stoma wide open. An arrow was also to be drawn across the cell wall and cell membrane directed towards the cytoplasm to illustrate movement of water entering the cell from neighbouring epidermal cells/intercellular spaces.

Most candidates were able to explain that *the cytoplasm of both plant and animal cells expand in dilute solutions but the presence of the cell wall prevented the plant guard cell from bursting, while animal cells burst as the surrounding cell membrane is unable to withstand the pressure exerted by the expanding cytoplasm of an animal cell* (Part (c)).

#### Question 4

The question tested candidates' knowledge of the structure of the human alimentary canal (digestive system), its role in the mechanical and chemical digestion of food, and storage (SO B2.7, 2.8, 2.10, 4.12 and 4.13). Performance on this question was disappointing with candidates earning marks ranging from 0 to 12 out of the available 15 marks. The mean was 4.

In Part (a), candidates were asked to explain, with the aid of a labelled diagram of the alimentary canal, how a sandwich consisting of bread and chicken is digested. This part of the question was poorly done by most candidates. The quality of the diagrams were generally poor and many diagrams drawn were not representative of the alimentary canal. Important organs such as the stomach, sections of the small intestine (duodenum, ileum) were often excluded from the diagram or misspelt in the labels/annotations. Most candidates were able to accurately describe *mechanical digestion/chewing in the mouth and grinding of food in the stomach to reduce the size of large pieces of food to smaller pieces. They also mentioned that this action increased the surface area of food for chemical digestion.* However, the chemical digestion of food nutrients was less well described. The role of the enzyme in the digestion of the starch in the bread to maltose was well known by most candidates. Some candidates were not aware *that salivary amylase is produced only in the mouth* and some referred to pancreatic amylase as salivary amylase. The enzymes involved in protein digestion were less well known. Very few candidates mentioned *the breakdown of proteins to polypeptides by the stomach enzyme, pepsin; or trypsin produced in the pancreas or peptidase enzymes in the small intestine break down polypeptides/proteins to amino acids.* Very few candidates also described the digestion of triglyceride lipids in the chicken by *lipase produced in the pancreas, aided by bile from the liver to produce glycerol and fatty acids.*



In Part (b), candidates were told that both plants and animals store some of their unused nutrients and in Part (b) (i), they were asked to name two storage organs in plants and the nutrients stored in each. Most candidates were awarded full marks for correctly naming the *seeds, fruits, leaves, stems* or *roots of plants* as storage organs and the nutrients (starch, proteins, lipids, vitamins, minerals or water) stored in them. A few candidates were not awarded marks because they gave the names of plant organisms such as tomato and onions.

Several candidates were also awarded full marks for suggesting three correct reasons why plants need to store nutrients in responding to Part (b) (ii). Their responses included *withstanding prolonged periods of harsh weather conditions such as drought/winter; to supply nutrients when light intensity is low and the plants are unable to photosynthesize; for growth and development of the embryo during germination; for asexual reproduction.*

### Question 5

This question examined candidates' knowledge of the components of blood and the role of blood in carrying oxygen to the cells for energy production (SO B4.4). It also tested their knowledge of sickle-cell anaemia, and their ability to use genetic diagrams to illustrate the pattern of inheritance of the disease (SO C 2.8). Performance on this question was also disappointing with candidates scoring between 0 and 14 out of the available 15 marks. The mean was 6.

Part (a) required that candidates name four major components of human blood, then explain how the oxygen transported by the blood becomes available to cells for the production of energy. Most candidates were able to name *red blood cells, white blood cells, platelets* and *plasma* as the major components of human blood, but a few who named substances (nutrients, oxygen and carbon dioxide) carried by blood were awarded no marks. Several candidates were also able to explain that *haemoglobin in red blood cells carries oxygen in the form of oxyhaemoglobin* and that *oxygenated blood is transported from the lungs and pumped by the heart to the rest of the body*. Only a few candidates were also able to tell that *the oxygen is released from the haemoglobin in the region of the cells/tissues where oxygen concentration is low; so oxygen will diffuse into the cells where it is used for aerobic respiration.*

Most candidates were able to describe at least one of the two symptoms associated with sickle-cell anaemia required in Part (b) (i). Correct responses included *fatigue/tiredness, breathlessness/difficulty breathing, swelling of the joints, joint pain, jaundice/yellowing of the eyes/skin and frequent infections*. Very few candidates were awarded full marks for their use of a genetic diagram to explain the chances of a child having sickle-cell anaemia if the parents are both carriers of the trait. Even though the question instructed candidates to use the symbols A for normal and S for sickle cell, many candidates used their own symbols. The expected response is as follows:

Parents' genotypes: AS × AS  
 Gametes: A, S × A, S  
 Fertilization cross:

Parental gametes	A	S
A	AA	AS
S	AS	SS

The chance of the child being born with sickle-cell anaemia (SS) is 0.25/ 25% /  $\frac{1}{4}$  .

### Question 6

This question tested candidates' understanding of genetic engineering technology, sources of variation, biological evolution, artificial and natural selection (SO C 5.1, 5.2, 6.1 and 6.2). Performance was below expectations, with candidates earning marks within the range 0 to 10 out of the available 15 marks. The mean was 2.

In Part (a), candidates were asked to describe the process of genetic engineering and state two advantages and disadvantages of the technology. Several candidates seemed to be unfamiliar with the process and only defined genetic engineering as a process whereby the genes of an organism are altered. They were expected to describe the technology as one whereby *a desired gene/gene of interest is isolated/taken from an unrelated species with the use of specific enzymes/restriction endonucleases and then inserted into a vector/plasmid using DNA ligase. The vector/plasmid is then introduced into the organism and the desired gene is inserted into the organisms' DNA/genome. The genetically altered organism will then express this gene/have a new combination of traits which do not occur in nature.* Most candidates were able to state at least one of the two advantages and two disadvantages. Advantages which were correct included: *genetically modified organisms are able to express the desired traits within a short period of time; genetically modified crops have desirable traits that enable them to survive better and expression of the gene of interest is guaranteed.* Disadvantages that were expected included: *genetic engineering technology is expensive, technical expertise is required to carry out the technology, genetically modified organisms may pose a risk to the environment; engineered variety may revert to the original genome because the gene gets lost or is not stable; and ethical concerns.* A common misconception was that genetic engineering increases the life span of organisms.

Candidates were told that a tomato farmer observes that one of his plants produces fruits with an attractive deep red colour which he wants to preserve, so he selects the seeds from this fruit for his next crop. In Part (b) (i), candidates were asked to suggest what may have led to the appearance of this deep red colour and describe one negative implication for biological evolution. Most candidates stated that the new red phenotype was the result of a mutation in the gene responsible for the fruit

colour. Several candidates said the red colour was due to environmental factors such as greater exposure to sunlight or use of inorganic fertilizers by the farmer. These candidates were not awarded any marks for their response because they did not recognize that the change took place at the level of the gene. Very few candidates were able to explain the implications for biological evolution. They were expected to explain that *the change in DNA may lead to the formation of a new species if the seeds produce plants that are unable to reproduce with the original tomato plants. The mutation may also result in the removal of certain other desirable characteristics in the species, like disease resistance which is responsible for the survival of the original species and hence these genes will be lost from the natural population.*

In Part (b) (ii), candidates were asked to describe an approach, other than selecting seeds that the farmer could have adopted for introducing new traits in his tomato crop. Very few candidates gave a satisfactory response to this part of the question. Most candidates suggested that genetic engineering was an alternate approach: gene for the desirable trait is isolated from an unrelated species and inserted into the crop plant. A few candidates also said grafting and tissue culture but were awarded no marks. The expected response was *a breeding programme (artificial selection) whereby the desirable gene is identified (from plants in the wild) or seeds from the crosses are planted and the offspring screened for the desired trait. These are then crossed and the offspring with the desirable gene are selected and propagated. Or the crosses are made between the crop plant and a relative which has desirable traits (for example, disease resistance, better quality fruit).* Candidates were also asked to explain how this process differs from the process occurring in nature. They were expected to explain that this is a type of *artificial selection. The new phenotype occurs naturally and it either survives or gets eliminated depending on its ability to survive in the environment. This will bring about a change in the alleles and form the basis for biological evolution. Artificial selection also takes longer to achieve its objectives.*

### **Paper 032 – Alternative to School-Based Assessment (SBA)**

This paper consisted of three compulsory questions that assessed *all* of the practical skills required of biology students. Candidates continue to display weak practical skills especially in aspects of drawing, planning and designing feasible methods for experiments that investigate biological phenomena, writing hypotheses, identifying precautions, interpreting data and writing conclusions. These observations suggest that many candidates did not have the practical experience required to develop these skills. These skills would also enable them to design experiments and manipulate experimental data on their own.

#### Question 1

This question examined candidates' practical skills in drawing and labelling a fish gill (SO A3.4, B1.7), as well as their ability to construct a table to present data that was used to plot a graph; ability to write a conclusion related to the data presented in the graph and table and use their knowledge of factors

that affect breathing to interpret the data. The mean was 10 out of 21 possible marks. Candidates were able to score marks ranging from 2 to 16.

In Part (a) (i), candidates' ability to use a ruler accurately was tested by instructing them to measure the distance from the mouth of the fish to the operculum (gill cover). This was well done by most candidates. However, drawing the gill was very poorly done by most candidates. Many candidates seemed unfamiliar with the fish gill and were unable to label the gill raker, lamellae and gill bar accurately. The thick gill lamellae seen in many drawings was usually not representative of the thinly divided ones seen in the specimen. Candidates are reminded that drawings should be done using clean continuous lines and not the sketchy ones often seen. Label lines should be drawn with a ruler and as far as possible, labels should be written on the same side of the drawing.

Part (b) asked candidates to explain two ways in which the gills of the fish are similar to the lungs of a human. This was not well done by most candidates. Candidates were expected to state that *numerous lamellae and alveoli provide a large surface area for gaseous exchange; the walls of both the lamellae and alveoli of the lungs are thin; both the lamellae and alveoli are surrounded by a network of blood capillaries for the transport of respiratory gases, oxygen and carbon dioxide diffusing in and out respectively at the respiratory surfaces. Both are also kept moist to allow diffusion to occur.*

In Part (c) (i), candidates were given a graph showing data obtained by scientists investigating the effect of heat pollution on the breathing rate of one species of fish. They were then asked to construct a table to represent the data in Part (c) (i), then write a conclusion that could be drawn from the data in response to Part (c) (ii). Most candidates were awarded at least two of the four marks allotted for having suitable row and column headings with units, and presenting accurate data. Many candidates did not use a ruler to construct a neat, enclosed table. Most candidates were able to write a suitable conclusion such as: *Heat pollution increases breathing rate among this species of fish.* If the conclusion was expressed in the form of an observation such as *Fish closer to the effluent had more frequent gill cover movements*, then the candidate was awarded only one mark.

Part (d) asked candidates to explain how temperature may affect the breathing rate of fish. Several candidates only got marks for stating that fish breathe faster to get more oxygen for aerobic respiration but they were also expected to include that *as the amount of dissolved oxygen decreases the temperature of water increases or that the amount of dissolved oxygen increases as temperature decreases up to a point. If the temperature is close to freezing point, the amount of dissolved oxygen is also low.*

In Part (e), most candidates were able to suggest at least one of two factors, other than temperature, that may affect the breathing rate of the fish. Expected responses included: *agricultural pollution, industrial pollution, organic pollution, high algal bloom, the number of fish living in the water, salinity, pH, high levels of carbon dioxide.*

## Question 2

This question examined candidates' ability to use a ruler to measure the length of roots growing between Days 2 and 8 of germination and construct a suitable table and a graph to present the data. It also tested their knowledge of the role of the cotyledons/seed leaves in germination and their ability to design an experiment with a suitable control to investigate the effect of light direction on the growth of the seedling at Day 8 after germination, and to explain how a plant's response to light is beneficial to the plant (SO B 6.1, 7.2, 7.4, 8.1, 8.4 and 4.12). Performance was satisfactory with candidates scoring from 0 to 16 out of a possible 17 marks. The mean was 8.

In Part (a), candidates were given a diagram of a pea seedling at different stages of germination over an eight-day period. Part (a) (i) required candidates to measure the lengths of the roots from the soil surface to the root tips between Days 2 and 8, and record the data in a suitably constructed table. This was well done by most candidates but a few candidates were only awarded three of the four marks because they did not include their unit of measurement (that is, mm or cm). However, most were able to accurately plot the values in their table using an appropriate scale to produce a line graph to represent the data.

Part (b) required candidates to suggest why the cotyledon leaves decrease in size between Days 6 and 8 whereas the primary leaves showed an increase from Day 7 to 8. Most candidates were awarded full marks for explaining that *the cotyledon got smaller as enzymes break down its food/nutrients stored for the developing seedling but the primary leaves get bigger as they get food and start photosynthesizing* on their own to make more food.

In Part (c) (i), candidates were asked to describe the procedure that some students could use to investigate the effect of light direction on the growth of a pea seedling, similar to that shown at Day 8. Most candidates were awarded two of the allotted three marks for stating that *the seedling is first placed in an enclosed space/container with one opening which allows light to reach the plant from only one side or through a small opening*. They were also expected to state that *the plant should be allowed to stand for a specified time period to allow the direction of growth to be observed* or that *all other requirements for growth such as water should be provided*. A few candidates stated in Part (c) (ii) that the control should consist of a plant seedling of the same size/species and must be subjected to the same conditions as the plant under investigation but either exclude light or expose the plant to light from all directions.

Part (d) was well done by most candidates as they were able to explain that *plant shoots benefit from growing towards light as they are able to get optimal/maximal amounts of light for making food/photosynthesis or making chlorophyll or producing oxygen for respiration*.

### Question 3

This question examined candidates' understanding of the properties and functions of enzymes. It assessed candidates' ability to write a hypothesis as well as plan and design an experiment to investigate if enzymes acting at low temperature hydrolyse stored sucrose (SO B2.8, 2.9 and 4.12). They were also required to state a precaution and a limitation, construct a suitable table for recording their results and explain how the expected results could be used to support the hypothesis. Candidates' performance was disappointing with scores ranging from 0 to 15, and a mean of 5 out of the 22 marks allotted for this question.

Candidates were told that John observes that leftover pineapple kept at 15 °C in the refrigerator tastes sweeter than that consumed just after being peeled (kept at room temperature); and he thinks this is because of an enzyme acting at low temperature to break down the stored sucrose to glucose and fructose. In Part (a), candidates were required to state a hypothesis to explain John's observation. This was poorly done as several candidates wrote an aim, such as to investigate the temperature at which sucrose is hydrolysed. A suitable hypothesis is that *the enzyme which breaks down sucrose works best at a temperature lower than room temperature.*

In Part (b), candidates were required to list the equipment and materials and describe a suitable procedure for investigating their hypothesis. Most candidates were able to list six or more suitable pieces of apparatus and materials for performing the experiment. Few candidates were able to describe an appropriate procedure. Most candidates were usually awarded marks for setting up at least two different samples of pineapple, one sample at room temperature and one sample at 15 °C. The apparatus was to be left for a specified amount of time at the different temperatures, then the Benedict's test performed. The expected result is an orange-red precipitate that confirms the presence of glucose. Procedures that involved tasting the pineapple to determine the results were not awarded marks, since this is not an accurate method of detecting sweetness.

Most candidates got at least one mark in Part (c) for stating one precaution to be taken in the experiment. Expected responses were *equal sample of pineapple/enzyme/substrate used; accurate measurement of temperature, and pineapple samples; allow equal time for ripening at different temperatures.* Other responses included *ensuring samples are taken from the same fruit/variety/age/stage of maturity.* Few candidates were able to give a limitation. Expected responses included *enzyme cannot be seen with the naked eye; samples taken from different parts of the pineapple may have different amounts of enzyme/ sucrose; other factors present such as microorganisms on the pineapple/in the refrigerator may impact the level of reducing sugar.*

In Part (d), candidates were asked to produce a table to show how the data from the experiment could be captured/recorded. Most candidates produced a neat table (drawn with a ruler) that had suitable row/column headings and stated the conditions/manipulated variables (for example, temperature) and results (for example, sugar content and colour change). Candidates should have included a title for their table.

In Part (e), candidates were required to explain how the expected results could be used to support the hypothesis. This was poorly done. Candidates were expected to state *that more reducing sugar present in the sample kept at low temperatures indicate that the enzyme is working optimally at these temperatures or vice versa.*

In Part (f), candidates were asked to outline how the experiment could be modified to determine the effect of pH on the enzyme's activity. This too was poorly done. Candidates were expected to state that *pineapple samples would be added to labelled containers with solutions at different pH levels (acidic, neutral and alkaline) and one with no solution as a control. The samples would be allowed to stand for a specified time period after which the contents would be tested for the presence of reducing sugar.*

In Part (g), candidates were given a graph showing the rate of enzyme activity at different pH levels for two enzymes. In Part (g) (i), they were required to deduce the optimum pH for each enzyme. Most candidates correctly identified that the optimum pH for Enzyme A was 2.3 (acidic) and 7.5 (neutral/slightly alkaline) for enzyme B. They were also able to state that Enzyme A is most likely to be active in the stomach which is the acidic portion of the alimentary canal.

**C A R I B B E A N E X A M I N A T I O N S C O U N C I L**

**REPORT ON CANDIDATES' WORK IN THE  
CARIBBEAN SECONDARY EDUCATION CERTIFICATE® EXAMINATION**

**MAY/JUNE 2016**

**BIOLOGY  
GENERAL PROFICIENCY EXAMINATION**

**Copyright© 2016 Caribbean Examinations Council  
St Michael, Barbados  
All rights reserved.**



## GENERAL COMMENTS

The May/June 2016 examination in Biology at the General Proficiency level was the 50th sitting of this subject conducted by CXC. Biology continues to be offered at both the January and June sittings of the examinations and continues to be one of the more popular of the single sciences offered by the CXC at the CSEC level. The performance of approximately 17 355 candidates was assessed this year. The examination comprises four papers: Paper 01 – Multiple Choice; Paper 02 – Structured/Extended Essay paper; Paper 03 – School-Based Assessment (SBA); and Paper 032 – Alternative to the SBA (offered only to private candidates).

The overall performance of candidates this year was better when compared to that of last year, with candidates achieving scores across the full range of marks in each question. It was observed that several candidates experienced difficulty on aspects of the examination because of their lack of knowledge of the specifics of biological concepts, particularly chemical digestion, energy flow, natural selection and genetic engineering. Many also displayed poor laboratory skills in reading a measuring cylinder accurately, interpreting the pH value of a chemical substance, drawing biological specimens and calculating their magnification. This suggested that they had limited practical experience.

In preparing candidates, particular attention must be paid to the comments, made in several previous subject reports and reiterated below, if the desired improvement in performance is to be realized and sustained. These comments relate both to test-taking techniques and ways of addressing the requirements of questions:

- Teachers should remind their students that there is more to taking an examination than memorizing the content. When preparing students for an examination, time should be spent practising **how to interpret** and answer questions clearly, concisely and to the point.
- Candidates must improve their test-taking skills. This includes practice in reading questions carefully and planning responses so that answers are organized in a logical and cohesive manner. They should avoid, as far as possible, unnecessarily repeating phrases included in the question.
- Biological jargon should be used where appropriate, and **spelling** of biological terms **must** be correct. Frequently misspelt terms included structures associated with the human eye – suspensory ligaments, circular and ciliary muscles and the fovea; parts of the female reproductive system – cervix, fallopian tube and uterus; parts of the leaf – stoma/stomata, epithelium, palisade mesophyll cells. It is not possible to award marks for incorrectly labelled structures where the incorrect label actually means something different; for example, if the 'cervix' is labelled 'cervical'.

It should be emphasised that candidates at this level are expected to demonstrate knowledge and understanding of fundamental principles and concepts, for example, the importance of maintaining a constant body temperature; the role of mechanical and chemical digestion; the interdependence of living organisms and their relationship with the physical environment; the relationship of structure to function in living organisms; the difference between excretion and egestion; and genetics and variation and their role in perpetuating species.

The Examining Committee suggests that teachers should use more constructivist approaches in the teaching of Biology. Such approaches would lead to their students being more involved in explaining their interpretation of biological phenomena, clarifying the content and being more fully engaged in problem solving activities.

The Examining Committee also encourages Biology teachers to share best practices in the subject area and keep abreast with the rapidly changing information in the field. In addition, advanced technology is at our disposal and the timely introduction of e-learning programmes across the region is viewed as potentially enabling opportunity. This innovation must be embraced by all as far as possible.

The Examining Committee once again reminds private candidates in particular to pay careful attention to the stimulus material in each question which is meant to guide them in providing the correct responses. Candidates are also being encouraged to review the subject reports posted on the CXC website which have similar recommendations about the approach to answering Biology examination questions.

## **DETAILED COMMENTS**

### **Paper 01 – Multiple Choice**

Paper 01 consisted of 60 multiple-choice items. Performance on this paper was satisfactory and was better than the performance in 2015.

Some of the topics that were most problematic for candidates were

- the role of decomposers
- the characteristics of insects
- the structure of mitochondria vs. chloroplasts
- osmosis and diffusion
- growth movements in plants
- the function of the various structures which make up the skin
- reproduction in flowering plants
- definitions of genetic terms: chromosome, gene, allele
- sex-linked inheritance
- speciation
- natural selection
- genetic engineering

### **Paper 02 – Structured and Extended Essays**

Paper 02 consisted of six questions, three of which were in the structured response format and three in the extended essay format. This paper tested all profile skill areas identified in the Biology syllabus. All questions were compulsory.

#### Question 1

This question dealt with some practical aspects of Biology, including plotting and interpreting graphs of enzyme activity, planning and designing investigations to obtain data from an enzyme investigation, and writing conclusions and describing precautions to be taken when doing experiments. Candidates were also required to display their knowledge of mechanical and chemical digestion. Most candidates attempted this question but performance was below expectation. The mean was 12 out of 25 marks.

In Part (a), candidates were presented with a table showing the number of oxygen bubbles counted per minute in test tubes in water baths at different temperatures, by students investigating the effect of temperature on the rate of reaction of the enzyme catalase. They were told that crushed potato was used as the source of the enzyme and hydrogen peroxide (the substrate) was added to each test tube. Some candidates were not familiar with the reaction between catalase and hydrogen peroxide and did not know that a product of that reaction is oxygen.

Most candidates were awarded full marks for accurately plotting a graph to represent the data as required in Part (a) (i). Marks were not awarded if the units of measurement were not included as part of the legend when labelling the axes, or if the scale used did not allow for at least 50 per cent of the grid provided to be used up. Candidates are reminded that the independent variable (which in this case was temperature) should be put on the X-axis while the dependent variable (in this case number of O<sub>2</sub> bubbles produced) should be placed on the Y-axis.

Very few candidates did not determine the optimum temperature for the enzyme to be 40° C in response to Part (a) (ii).

Part (a) (iii) was incorrectly done by several candidates. This part of the question asked candidates to **explain** the shape of the graph at specified temperatures. Most candidates poorly described trends observed in the graph, as they were clearly unaware of the biological explanation for these trends. Candidates were expected to explain that between 0° C to 10° C there is little or no energy to cause the collision of the substrate with the enzyme active site for a reaction to take place. Between 11° C to 40° C, the increasing temperature increases the kinetic energy of enzyme and substrate molecules and this causes an increase in enzyme activity due to an increase in the number of substrate molecules that collide with the enzyme. As more substrate reacts with the enzyme active site, more product (oxygen in this case) is therefore produced. While most candidates were able to state that the enzyme works best at 40° C and that they are denatured at temperatures above 40° C, only a few of them were able to fully explain that because enzymes are proteins, they lose their three-dimensional structure at high temperatures and the resulting change in the structure of the active site prevents it from reacting with or binding to the substrate. Hence a sharp decline in the amount of product/bubbles formed was observed at temperatures above the optimum.

Most candidates were able to write a suitable conclusion in response to Part (a) (iv). Responses that were awarded full marks included: *The optimum temperature of catalase is 40°C; Catalase is denatured at temperatures above 40°C.*

In Part (a) (v), candidates were asked to suggest a reason why living organisms need to maintain a constant internal temperature. Candidates were awarded the mark if they stated that this was to allow enzymes to work optimally or to prevent the denaturing or inactivity of enzymes. Marks were not awarded for vague responses such as “to help the body work properly.”

Most candidates were awarded full marks for stating two precautions as required in Part (vi). Correct responses included: *Ensuring that each water bath was kept at a constant temperature; using the same amount of enzyme and/or substrate in each test tube; allowing equal time for the reaction in each test tube to take place.*

In Part (vii), candidates were asked to state how they would modify the investigation to determine the effect of pH on enzyme activity. Most candidates were only able to get one of the two marks allocated because they stated that solutions/liquids of different pHs should be added

to each test tube. Candidates who mentioned that the temperature should be the same, equal amounts of enzyme and/or substrate should be added to each test tube and the number of bubbles given off for each pH counted were also awarded the other mark. A common misconception was that different concentrations of hydrogen peroxide have different pH values.

Performance on Part (b) was unsatisfactory. Candidates were expected to name two enzymes that function in protein digestion and describe their role. Several candidates named protease, which referred to the class of enzyme. The expected responses were (i) pepsin, which breaks down proteins to polypeptides in the stomach, and (ii) trypsin, which breaks down proteins in the small intestine to amino acids.

Performance on Part (c) was also disappointing. In Part (c) (i), candidates were expected to list the mouth and stomach as the parts of the alimentary canal responsible for the mechanical digestion of food. "Teeth" was also accepted as a response. Most candidates, however, were able to explain that mechanical digestion is important to increase the surface area of substrates to allow enzymes to work optimally and to make swallowing easier, in response to Part (c) (ii). They were also awarded full marks for explaining that chemical digestion allows complex food nutrients to be broken up into their simplest form so that these simple nutrients can be absorbed and assimilated by the body.

## Question 2

This question tested candidates' knowledge of the feeding relationships among a group of organisms found in a particular habitat and the ability to construct a food web and a food chain, given a set of organisms with which to do so. It also tested the important concept of flow of energy in the system and candidates' ability to explain why, unlike nutrients, energy flows in one direction; that is, it is not recycled.

In Part (a) (i), marks were awarded for algae at the start of the web (1 mark); eagle at the highest trophic level (1 mark) and arrows pointing in the correct direction (1 mark). Any misconceptions about the feeding relationships among the other organisms were accounted for in Part (iii), in which candidates were asked to identify from the web constructed: "secondary consumer, both prey and predator" etc. Therefore, marks were not deducted for the orientation of the web, that is, algae at the top; and the candidates were only penalized for the arrow mark if they drew lines instead of arrows connecting the organisms, or had the arrows pointing in the wrong direction.

In response to Part (a) (ii), most candidates correctly identified the role of the organism at the start of the web as the producer which converts solar energy to chemical energy and which introduces energy into the food web/chain. They also correctly recognized prey, predator and consumers at the different trophic levels.

In constructing the food chain from the web in Part (a) (iv), a few candidates ignored or did not comprehend the meaning of "THREE organisms". Their food chains consisted of three arrows (four organisms) or **all** the organisms from their web. However, once the organisms were in the correct order in a chain from the web drawn, they were awarded the mark. It is still important to impress upon candidates the importance of reading the question carefully, underlining key words if needed so that they increase their chances of answering the questions correctly.

Parts (v) and (vi) posed the greatest challenge for most candidates. The role of the organism to which the arrow points is to keep the population in the previous trophic level in check (maintain balance of the various organisms in the habitat). However, the most common response given

(which was accepted) was “consumers feed on organisms in the previous trophic level”. Predator was not equally acceptable, since primary consumers to which arrows also point do not fit into the category of predators. Responses expected for Part (vi) included that energy cannot be recycled/returned to the prey or organisms at the lower trophic levels; it is lost as heat during metabolic activity; only about 10 per cent of the energy is transferred to the next trophic level; and it is stored in the organism and is released only on death and decay. Very few students were able to score the 2 marks for this part.

Most candidates were able to earn the 3 marks for Part (b). Features that support living organisms include: sunlight, water, oxygen, carbon dioxide and nitrogen; habitat (land, lakes, ponds, oceans etc); food/nutrients; soil; temperature; biodiversity (producers, predators). Marks were **not** awarded for biotic and abiotic factors which were not only too general but in addition, included among these are many factors, for example, toxins, extreme weather conditions and drought, which do not support living organisms.

### Question 3

This question tested candidates’ knowledge of the terms used in a reflex arc as well as their knowledge of the structure and function of the mammalian eye.

Part (a) required students to give definitions of ‘stimulus’, ‘receptor’ and ‘effector’. This part was not very well done especially by those candidates who simply gave the common English meanings. Many candidates did not state that a stimulus in the biological sense is a **detectable** change in the environment of an organism.

Part (b) (i), where candidates were asked to label the parts seen in a section through the mammalian eye, was fairly well done. In Part (b) (ii), candidates were asked to explain why the ‘blind spot’ was so called. Most of them were able to explain that because light-sensitive cells were absent from this area no images could be formed.

Part (c) asked for an explanation of the changes that take place in the eye when a boy looks up from reading a book to see a distant helicopter. This part was generally not well done as many candidates were unclear about the functions of the ciliary muscles and suspensory ligaments in adjusting the curvature of the lens for bending light rays coming from a distant object.

In Part (d), candidates were given two images showing eyes with pupils adjusted for dim and bright light and asked to determine which image represented the eye adjusted for dim light. Most candidates correctly identified image ‘A’ as the one adapted for dim light since this would allow more light to enter the eye. However, the majority were unable to gain the third mark for this part of the question since they did not correctly explain the antagonistic contraction and relaxation of the radial and circular muscles of the iris which result in dilation of the pupil.

Most candidates responded correctly to Part (e) by indicating that the retina would be damaged if exposed to very bright light.

#### Question 4

This question assessed candidates' knowledge of the human female reproductive system, the site of fertilization and contraception. Their ability to use the characteristics of flowers to identify their method of pollination/reproduction was also assessed.

In Part (a), they were asked to draw a labelled diagram of the female reproductive system then use an arrow to illustrate the path taken by a spermatozoon to fertilize an ovum. Most candidates were able to score 4 of the possible 6 marks because they were able to correctly name at least five of the parts of the female reproductive system, namely, vagina, cervix, uterus, oviduct/fallopian tube and ovaries. Unfortunately, several candidates were unable to gain full marks because they spelt important words such as uterus and fallopian tube incorrectly. Candidates who placed an arrow into the ovary were not awarded marks as the site of fertilization is the oviduct.

Most candidates were awarded full marks for their response to part (b). Correct reasons for opting for the barrier method included the fact that it is temporary and allows them to have children later; its effect in preventing STIs; the avoidance of surgical complications; it causes less/no psychological/mental stress; it is cost-effective/cheap/affordable/easy to get; it carries few associated health risks. The responses to the part relating to disadvantages of the surgical method included the fact that it is permanent and irreversible, therefore prevents any future pregnancy; it may encourage promiscuity and so increases the chance of spreading STIs; it will not prevent STIs; it may be associated with health risks or complications; it may result in post-operational pain and it is expensive.

Candidates were told that a biologist discovered flowers of a species of plant with no male reproductive parts in Part (c). They were expected to use this information and suggest a method by which this plant reproduces and state three advantages of the method. This was satisfactorily done as several candidates recognised that the plant could reproduce either asexually (for example, by means of stem cuttings or root tubers) or by way of cross-pollination, using pollen from flowers of another related plant species. They were expected to give the advantages of either asexual or sexual reproduction as appropriate. Some candidates confused the terms pollination and fertilization.

#### Question 5

This question tested the candidates' knowledge of photosynthesis; adaptations of the leaf to capture maximum sunlight and carbon dioxide and the role of decomposers in the carbon cycle.

While most candidates were able to write the balanced equation for photosynthesis to earn the allocated 2 marks, there were a few who wrote the equation for respiration, while some had oxygen and carbon dioxide on the wrong side of the equation and a few wrote that energy was given off. Four marks were awarded for any four of the following points for the definition of photosynthesis: requires sunlight as a source of energy; needs chlorophyll (green plants); makes food/glucose/complex organic compound; releases oxygen as a byproduct; converts simple inorganic compounds ( $\text{CO}_2$  and  $\text{H}_2\text{O}$ ). The question asked for leaf adaptations related to the capture of light and  $\text{CO}_2$ , therefore the roles of xylem and phloem vessels were not accepted. The adaptations, for example, large surface area or leaf orientation had to be linked to their role, in this case 'to capture maximum sunlight'. Similarly, the location of palisade cells, position of chloroplast and arrangement of chlorophyll in the lamellae are to capture sunlight. No marks were awarded for simply stating that the presence of chloroplast and chlorophyll was needed for

the process. Candidates were required to link the presence of guard cells and numerous stomata on the underside of leaves to the diffusion of carbon dioxide into the leaves.

In Part (b), on the role of decomposers in providing carbon dioxide for plants, proved challenging to some candidates, especially with regard to the release of carbon dioxide into the atmosphere. While most carbon cycles in the text books indicate that the CO<sub>2</sub> released is from respiration by these organisms, CO<sub>2</sub> released as a result of thermal decomposition of carbonates, which is facilitated by the enzymes secreted by these organisms, was hardly mentioned. Candidates were given a mark if they simply stated that CO<sub>2</sub> is released in the atmosphere as a result of the breakdown of dead organisms. Marks were also awarded for recognising that decomposers were saprophytes (fungi and bacteria); that they secrete enzymes to cause the breakdown of complex organic compounds in dead organisms, which they then absorb and respire to release the carbon dioxide. This was an essay question and therefore required an explanation of how plants utilized the CO<sub>2</sub>; simply writing that it "...was made available to plants" as stated in the question was not awarded a mark.

### Question 6

This question tested candidates' knowledge of disease, genetics and natural selection. Part (a) of the question asked for the causes and symptoms of anaemia. This part was fairly well done, as most candidates displayed adequate knowledge in this area.

Part (b) (i) asked for definitions of the terms 'homozygous' and 'heterozygous'. Performance on this part was better than in previous years but still too many candidates did not use the term 'allele' correctly in defining the homozygous and heterozygous genotypes.

In Part (b) (ii), candidates were asked to use a genetic diagram to show how a couple without sickle cell anaemia could have offspring with the disease. A few candidates responded very well by presenting all the steps expected in a genetic diagram, that is, parents' phenotypes; parents' genotypes; parents' gametes; fertilization cross; offspring genotypes and offspring phenotypes.

Many misconceptions were seen in the responses to Part (b) (iii), so it was clear that most candidates did not grasp the concept of natural selection. Many of them seemed to have forgotten that malaria is a pathogenic disease and wrote about children inheriting the malaria 'genes'. Very few candidates used the terms 'selective advantage' and 'selection pressure' in the correct contexts. Most missed the key point that carriers of the sickle cell allele survive malaria and can reproduce to pass on this allele to the next generation hence accounting for the high frequency of the sickle cell allele in areas where malaria is rampant.

### **Paper 032 – Alternative to the SBA**

This paper assessed most of the practical skills required of biology students. Candidates continue to display weak practical skills especially in aspects of planning and designing, including manipulating apparatus, describing methods of experiments, identifying limitations and in drawing conclusions from data. These observations indicate that in developing practical skills it is vital that teachers and instructors expose private candidates to actual conducting of experiments and investigations of scientific phenomena, discussions, explanations and rationalizing of procedures and outcomes so that candidates may become capable of developing and manipulating experiments and experimental data.

### Question 1

This question tested candidates' practical skills in determining the water-holding capacity and pH of soil samples. They were also required to identify sources of error, write a suitable conclusion and identify other abiotic factors associated with the investigation. The question also assessed their ability to classify soil organisms and present this information in a table, as well as to determine a suitable habitat related to the characteristics of the soil and methods of collecting organisms from soil.

Each candidate was provided with 10g of two different types of soil, labelled X and Y, taken from two different locations. They were then given instructions how to use moistened filter paper, funnels, 50 ml of water and a timer to determine the water-holding capacity of each soil. Part (a) was well done by most candidates. Several candidates were able to get full marks for Parts (a) (i) and (a) (ii) if they followed the instructions given. They were also able to accurately identify the presence of water in the original soil samples, spilling of water during pouring, incorrect placement of the filter paper and incorrect reading of the measuring cylinders as potential sources of error in the experiment. In Part (a) (iv) they were also able to state problems such as ease of water logging, limited air available, limited soil organisms and plant roots rotting as being associated with high water-holding capacity or the ease of desiccation of the soil and leaching of soil nutrients as being associated with low water-holding capacity.

Part (b) required that candidates use indicator paper to determine the pH of the soil samples. Some candidates did not know how to interpret the pH values/colour changes obtained using indicator paper and were unable to get full marks. Candidates are reminded that the pH scale ranges from 0 to 14. A pH value of 7 indicates neutral, values less than 7 indicate acidity and values above 7 indicate alkaline conditions.

Several candidates were able to state at least one other abiotic factor that could be investigated to determine the suitability of the different locations for setting up a school garden based on the results presented as required in Part (c).

Candidates were given drawings of soil organisms in one of the soil samples in Part (d) then asked to identify two features that could be used to classify them into at least two groups then classify them in Part (ii). This was problematic for most students. Tables in Part (ii) were not awarded marks if row and column headings were not related to the features and did not allow classification into at least two groups.

Appropriate responses related to the data presented in the question were given for Part (iii) with respect to the appropriateness of the soil for setting up the garden. Part (d) (iv) was also well done as most candidates were able to give two suitable methods for collecting the soil organisms. These included using pooters, jars, bottles, sieves, strainers, shovels and nets.

### Question 2

This question tested candidates' comprehension of the experiments used to demonstrate (i) that carbon dioxide is produced during respiration of animals, and (ii) that oxygen is produced during photosynthesis and to distinguish between excretion and egestion.

It was clear from the number of candidates who failed to respond or who produced poor attempts, that many candidates were not familiar with these popular experiments. Errors made in the experiment on respiration related to the chemicals required to **absorb** carbon dioxide:



NaOH, KOH or soda lime and that required to **test** for CO<sub>2</sub>: lime water or Ca (OH)<sub>2</sub>, referred to by some as lime juice.

The aim was to investigate whether CO<sub>2</sub> is given off during the respiration of small animals. Precautions had to do with the appropriate insertion of the glass tubing into the flask/liquid, the state of the animal (live, healthy) and making sure that the apparatus was airtight. The control was the absence of the animal in Flask III, keeping all other flasks the same as for the experiment.

In Part (b), few candidates were able to list the apparatus and describe the experiment to investigate the production of oxygen by the water plant, elodea. It required placing a freshly harvested piece of the water plant into a beaker half-filled with sodium bicarbonate solution (water was accepted) over which a funnel was placed upside down. A boiling tube filled with water was inserted over the stem of the inverted funnel and the apparatus was placed either in sunlight or in front of a light source. After a few hours, the gas collected in the boiling tube was tested for oxygen using a glowing splint. Candidates were expected to describe the test for oxygen and the expected result. For those who attempted this question, many did not fill the boiling tube with water and few used bicarbonate solution as a source of CO<sub>2</sub>.

In Part (c), as in previous years, many candidates had difficulty explaining the terms excretion and egestion.

### Question 3

This question tested the candidates' drawing skills and knowledge of the structure and function of synovial joints.

Part (a) (i) asked candidates to draw and label chicken leg bones. The majority of candidates displayed extremely weak drawing skills. Guidelines for developing drawing skills can be found in the CSEC Biology syllabus and candidates should use these while preparing for Biology examinations.

For Part (a) (ii) candidates were asked to calculate the magnification of their drawing. This was not done very well, as most candidates did not appear to know the formula that should be used for doing this calculation (that is, length of drawing/length of specimen).

In Part (b) (i), only a few candidates recognized that the joint between the femur and the tibia is a hinge joint. The answers given by those candidates to (b) (ii), which asked for a reason for choice of joint type, were incorrect.

Most candidates gained marks for their answers to Part (b) (iii) since they stated that cartilage and fat protect the ends of bones. The term 'synovial' fluid was seldom used; most candidates referred to this as a 'lubricating' fluid.

**CARIBBEAN EXAMINATION COUNCIL**

**REPORT ON CANDIDATES' WORK IN THE  
CARIBBEAN SECONDARY EDUCATION CERTIFICATE®  
EXAMINATION**

**JANUARY 2017**

**BIOLOGY**

**GENERAL PROFICIENCY EXAMINATION**

**Copyright © 2017 Caribbean Examinations Council  
St Michael, Barbados  
All rights reserved.**

## GENERAL COMMENTS

The January 2017 examination in Biology continues to be offered in both January and June. The examination comprises three papers: Paper 01 – Multiple Choice; Paper 02 – Structured/Extended Essays; and Paper 032 – Alternative to School-Based-Assessment (offered only to private candidates).

The overall performance of candidates this year was better than that of candidates in 2016, with more candidates scoring across the full range of marks in most questions. Topics such as the function of enzymes in digestion, the cellular structure of microbes such as bacteria, blood clotting, gaseous exchange in plants, immunity, inheritance of sex linked alleles, artificial selection and genetic engineering presented major challenges for many candidates.

Teachers and private candidates should try as much as possible to cover all aspects of the syllabus, particularly Section C. More time needs to be devoted to practising how to interpret and answer questions clearly and concisely and not just to memorizing biological processes. Candidates should also be encouraged to read questions carefully, underline key terms and review answers before submitting papers at the end of the examination. Biological jargon should be used where appropriate, the spelling of biological terms needs special attention as candidates sometimes were unable to gain marks because examiners were unclear if they knew what they were talking about.

An improvement was observed in candidates' performance in practical skills, especially with respect to plotting graphs. Emphasis still needs to be placed on developing candidates' ability to demonstrate their skills in responding to practical based questions on the Alternative to SBA paper. Activities involving the reporting of data using suitably constructed tables/drawings; analysis and interpretation of data; planning and designing experiments to investigate well-written hypotheses should be encouraged. Private candidates should also seek to enhance their practical skills by making use of relevant simulation laboratory experiments, several of which are accessible via the internet, if they are unable to get practical experience under the supervision of a classroom teacher.

Candidates and teachers are being encouraged to make use of online resources available on the CXC's website, <http://www.cxc.org>, such as Biology subject reports for previous CSEC Biology examinations, exemplars and online tutorials. It is suggested that teachers adopt a constructivist approach to the teaching of Biology and try to creatively tap into the digital literacy skills of their students by posting lectures on social media pages or YouTube, so students can use these resources to aid their learning instead of relying solely on textbook resources and class notes.

Candidates and teachers are being asked to note the strengths and areas of weakness in candidates' performance in this sitting of the examination and to pay careful attention to the following recommendations made by the examining committee, reiterated in this, as well as in previous reports, in order to enhance the quality of performance in future examinations.

## DETAILED COMMENTS

### Paper 01 – Multiple Choice

Paper 01 consisted of 60 multiple choice items. Several candidates found the following topics problematic:

- Transport in plants
- Surface area to volume ratio
- Eye defects
- Germination
- Vectors of infectious disease
- Sexual reproduction
- Cell division by mitosis vs meiosis
- Definition of chromosomes, alleles and genes
- Definition of species

### Paper 02 – Structured and Extended Essays

Paper 02 consisted of six compulsory questions, three of which were in the structured response format and three in the extended essay format. Several candidates were unable to score marks across the full range for all questions.

#### Question 1

This question assessed candidates' ability to accurately plot and interpret graphs, state precautions to be taken when performing experiments and demonstrate practical skills in testing for the presence of proteins. It also tested their knowledge of protein digestion and the roles of protein in plants, and their ability to identify feeding relationships. The question tested specific objectives (SO) A3.7, B2.5, 2.6, 2.8 and 2.9 and all three profile skill areas identified in the Biology syllabus – Knowledge/Comprehension, Use of Knowledge and Experimental Skills. The question was marked out of 25 and candidates were able to access marks across most of the range (0 to 22). The mean mark awarded was 11.

In Part (a), candidates were given a table with the results of an investigation of the rate of reaction of an enzyme, X, at different temperatures. In Part (a) (i), candidates were required to accurately plot the data on the grid provided. Several candidates got three of the four marks for accurately plotting a line graph using an appropriate scale and labelling the axes correctly. These candidates did not get full marks because the legend used to label the axes did not include the units °C for *temperature* and *mg of product per minute* for rate of reaction of Enzyme X. Most candidates who used a suitable scale to plot their graph in Part (a) (i) were able to accurately identify the optimum temperature of Enzyme X from the graph plotted as 30 °C, as was required in Part (a) (ii). Very few candidates were unaware that the

optimum temperature was the temperature at which the highest amount of product was formed per minute/fastest rate of reaction occurred.

Most candidates were, however, unable to account for the shape of the graph in Part (a) (iii). Candidates were expected to explain that *between 5 and 30 °C, the increasing rate of collision between the enzymes and the substrate caused more substrate to bind to enzyme active sites and so products formed more quickly*. They were also expected to state that the enzyme is denatured above 40 °C and so the substrate is no longer able to fit into the active site and no more products are formed.

In Part (a) (iv), most candidates were able to correctly state a precaution to be taken when carrying out the experiment to prevent errors. The most frequently stated ones were *ensuring that the temperature at which each rate of reaction is measured is kept constant/maintained; ensuring that the time allowed for the reaction between the enzyme and the substrate at each temperature is the same; ensuring that the ratio of enzyme to substrate reacting at each temperature is the same and keeping the pH the same for each reaction mixture*. Candidates who stated safety precautions instead of actions to be taken to prevent errors occurring in the experiment were not awarded marks.

Part (b) was well done by most candidates. Several candidates were familiar with pepsin and trypsin, enzymes that break down proteins, in response to Part (b) (i). These candidates were also able to correctly name the *stomach* and the *small intestine* as the two parts of the alimentary canal where these enzymes are found, in answering Part (b) (ii). However, Part (b) (iii) was challenging for most candidates, especially those who were not familiar with the properties of enzymes. Candidates were expected to suggest that *the reason why the different enzymes involved in the breakdown of proteins are located in two different parts of the alimentary canal are that the pH conditions are different in each location; enzymes are specific and there are several different types of proteins in food*.

Parts (c) (i) and (ii) were poorly done by some candidates who were not familiar with the relationship between leguminous plants such as peanuts and nitrogen fixing bacteria. In response to Part (c) (i), common misconception observed was that these candidates identified the relationship as commensalism because they thought that only the plants benefit by being able to obtain nitrogen for making their proteins. The bacteria also benefit by having a habitat in the root nodules of these plants so the relationship is described as mutualism.

Part (c) (iii) was poorly done by most candidates. Several candidates were not awarded marks because they could not describe the procedure for testing a sample of peanuts for proteins. They were expected to describe *how a sample of peanut is crushed/grounded, then a specified amount of sodium hydroxide (NaOH) or potassium hydroxide (KOH) is added followed by drops of copper sulphate solution*. Alternatively, they could also state that *a specific amount of Biuret solution is added to the sample*. Most candidates were awarded one mark for stating that the colour expected if protein is present is *purple/violet/lilac*.

Most candidates were also awarded at least one of the two marks in Part (c) (iv) for stating that *plants need protein to support growth or for the formation of new cells/tissues*. Other roles include *making enzymes and storage*.

## Question 2

This question examined candidates' knowledge of plant, animal and microbial cells, the function of organelles, and the behaviour of plant and animal cells in solutions of different concentrations (SO B 1.1, 1.2, 1.4 and 1.6). Performance on this question was satisfactory, with candidates scoring across the full range of available marks (0 – 15). The mean was 7.

In Part (a) (i), most candidates were awarded full marks for stating three differences between plant and animal cells. Common differences identified were that *plant cells have a cell wall while animal cells do not; a typical plant cell has a chloroplast while an animal cell does not; a typical plant cell has a large permanent vacuole but an animal cell has small, temporary vacuoles*. A few candidates also correctly mentioned that *a typical plant cell has starch grains as food stores but a typical animal cell does not; some have glycogen for storing excess sugar*. Part (a) (ii) was, however, not well done. Only a few candidates knew that *prokaryote cells refer to bacteria that do not have a nucleus to contain their genetic material, unlike eukaryotes such as plants or animal cells that have their genetic material lying in their cytoplasm*. Another difference is that *prokaryote/bacterial cells lack membrane bound organelles such as mitochondria, vacuoles, chloroplasts, while eukaryotic cells have membrane bound organelles*. Other distinguishing features that could have been mentioned include *prokaryotes have smaller ribosomes (70s) while eukaryotes have larger ones (80s); prokaryotes have pili while eukaryotes do not*.

Part (b) was well done as most candidates knew that *the cell wall protects the cell membrane from rupturing when the cell takes in excess water and that the cell membrane regulates the movement of substances into and out of the cell*. Candidates who incorrectly said that the cell wall controls what goes into and out of the cell were not awarded marks.

Part (c) was challenging for many candidates. Part (c) (i) examined candidates' knowledge of what happens to an animal cell placed in a concentrated sucrose solution. Candidates who said that *the cell would lose water and consequently would shrink* were awarded the marks. Those who incorrectly said that the cell would get turgid were not awarded the mark. In Part (c) (ii), candidates were expected to state that *the animal cell placed in distilled water would gain water and expand, and the cell membrane would eventually rupture because it is unable to withstand the pressure*. Parts (c) (iii) and (iv) tested candidates' ability to distinguish what would happen to a plant cell in a concentrated sucrose solution and in distilled water from what happened in the case of the animal cell. Candidates were expected to explain that *unlike the entire animal cell that shrinks in size, only the cell cytoplasm and cell membrane of the plant cell would pull away from the plant cell wall (become plasmolysed) as the cell loses water*. Few candidates mentioned that *the size of the*

*plant cell remains the same as the cell wall remains intact even though the cell contents shrink.* Most candidates were able to get full marks for explaining that *the plant cell in distilled water will expand and become turgid as water enters the cell but the membrane merely pushes against the cell wall and does not rupture.*

### Question 3

This question tested candidates' ability to identify the components of blood, their knowledge of the blood clotting process, inheritance of the sex linked gene haemophilia and the role of blood clotting in natural immunity (SO B 4.4, 4.5 and C2.10). Performance on this question was poor, although candidates were able to score marks across the full range (0 – 15). The mean was 4.

Few candidates were able to identify the platelets (labelled A) and only some were able to identify the white blood cells (labelled B) in the diagram provided in Part (a) (i). Most were, however, able to identify the red blood cells (labelled C in the diagram). Only a few candidates were also able to name the platelets as the components responsible for blood clotting in response to Part (a) (ii).

In Part (b), candidates were asked to complete a flow diagram to illustrate the steps involved in the clotting of blood. This was poorly done as most candidates appear not to have been familiar with the process. Candidates were expected to state that *in the first step, clotting factors are released from platelets, then prothrombin circulating in plasma is converted to thrombin which in turn converts fibrinogen circulating in plasma to fibrin.*

Part (c) examined candidates' ability to explain the inheritance of sex linked genes. In Part (c) (i), candidates were told that the allele for blood clotting is located on the X chromosome and they were expected to complete a genetics diagram to illustrate the outcome of a female who is a carrier but with normal clotting ability, mating with a male with similar ability. This was poorly done by most candidates. Candidates were expected to state the genotype of the male parent as  $X^H Y$  and the male gametes as ( $X^H$ ) (Y), then use this information to complete the fertilization cross using the punnet square as follows:

Gametes ♂	$X^H$	$X^h$
♀		
$X^H$	$X^H X^H$	$X^H X^h$
Y	$X^H Y$	$X^h Y$

Most candidates who did Part (c) (i) correctly were able to state that the probability of the couple having a haemophiliac child is 0.25 (or 25 per cent or  $\frac{1}{4}$ ), in response to Part (c) (ii). In Part (c) (iii), they were also able to explain that the likely sex of the haemophiliac child is male because males inherit their X chromosome from their mothers and since one of the mother's X chromosome carries the haemophiliac allele, there is a 50 per cent chance that a male child will inherit that allele. The female child gets one of her X chromosomes from the

father so if that father is not a haemophiliac, she will either be a carrier ( $X^H X^h$ ) or normal ( $X^H X^H$ ).

Part (d) required that candidates suggest why haemophiliacs may be more susceptible to infectious disease. Only a few candidates were able to correctly suggest that because *the blood of haemophiliacs will not clot, pathogens, which cause infectious diseases, are likely to enter through open wounds/cuts in the skin* or that *clotting repairs the protective barrier formed by the skin*.

#### Question 4

This question tested candidates' knowledge of how oxygen in the atmosphere becomes available to human and plant cells for respiration, as well as the impact of smoking heavily on the human respiratory system (SO B2.2, 2.3, 3.3 and 3.5). Performance on this question was poor, with the mean mark awarded being 5 out of 15.

In Part (a), candidates were asked to describe how oxygen in the atmosphere becomes available to human blood for delivery to the cells and then to explain how that process differs from the way plant cells obtain oxygen for respiration. Most candidates only mentioned that oxygen is taken into the lungs and carried to the cells by blood pumped by the heart without describing the processes involved. Candidates were expected to describe how *humans inhale oxygen through their nose/mouth when the diaphragm contracts/flattens and the external intercostal muscles contract causing the rib cage to move upwards and outwards. This causes the volume of the thorax to increase and the pressure to decrease and oxygen flows into the alveoli in lungs through the air passages (that is, the trachea then the bronchi). The oxygen then diffuses along a concentration gradient across the walls of the alveoli and combines with the haemoglobin in red blood cells being carried by blood capillaries surrounding the alveoli. The blood becomes oxygenated and is transported from the lungs by the pulmonary vein to the heart, which then pumps it to the body cells. The oxygen in blood being carried by capillaries then diffuses into the body cells. In plants, however, atmospheric oxygen becomes available to the cells by simple diffusion. Atmospheric oxygen enters the leaves by diffusion along an oxygen concentration gradient between the leaf and the air through stoma, and some of the oxygen is produced as a byproduct of photosynthesis. The oxygen occupies the air spaces then diffuses into the surrounding plant cells*.

In Part (b), candidates were asked to suggest six reasons why humans who smoke heavily have less oxygen available to cells for respiration. This was poorly done as few candidates appear to be familiar with the effects of cigarette smoking on the respiratory system and hence on the availability of oxygen for respiration. Candidates' responses were expected to include the following consequences of heavy smoking:

- *Constriction of the airways (that is, trachea/bronchi/bronchioles) which reduces lung function and causes breathlessness/reduced air/oxygen flow*



- *Shortness of breath/difficulty breathing which limits oxygen intake*
- *Destruction of cilia which leads to a buildup of mucus in the lungs/alveoli, making it difficult for oxygen to diffuse across the alveolar walls into the blood for transport to the cells so less oxygen is available to the cells*
- *Exposure to carbon monoxide which combines more efficiently with haemoglobin and lessens the amount of oxygen carried by haemoglobin to cells for respiration*
- *Emphysema/destruction of alveoli so there is a reduction in the respiratory surface and less gaseous exchange takes place so less oxygen is transported to the cells; there is also impaired breathing*
- *Exposure to tar and other carcinogens, which lead to lung cancer, which makes breathing difficult/painful and so less oxygen is inhaled*
- *Nicotine in cigarettes causes blood vessels to get narrow/constrict limiting blood flow and hence the amount of oxygen carried to the cells*
- *Plaque formation in arteries which can limit/cut off the oxygen supply to cells.*

### Question 5

This question examined candidates' knowledge of the path taken by blood from the heart to the body cells, physiological diseases and immunity (SO B4.3, 4.5, 4.8, 10.1). Performance on this question was also very poor, with the mean mark awarded being 3.

Part (a) (i) required that candidates describe the pathway taken by blood as it flows into the heart from the lungs until it is pumped out of the heart to be sent to the rest of the body. Very few candidates were able to explain that *blood is transported from the lungs by the pulmonary veins to the left atrium of the heart. It is then pumped through the bicuspid valve into the left ventricle; then from the left ventricle it is pumped through the semilunar valves into the aorta. The aorta then takes blood away from the heart to the rest of the body.* In Part (a) (ii), candidates were asked to identify two physiological diseases that affect the circulatory system. Few candidates gave correct responses which included *hypertension, atherosclerosis, arteriosclerosis, coronary heart disease, diabetes and chronic kidney disease.*

In Part (b), candidates were told that chemotherapy is a treatment that destroys both malignant (bad) cells and the good cells in the body. They were then asked to explain why a person undergoing chemotherapy would have decreased natural immunity. Candidates were expected to apply their knowledge of the role of 'good' cells involved in natural immunity such as *white blood cells, phagocytes and lymphocytes*, to explain that *their destruction during chemotherapy would cause these persons to be more susceptible to infectious diseases as they would lose the ability to fight/destroy pathogens effectively and neutralize toxins.*

Part (c) was also challenging for most candidates. They were given a scenario involving Peter, who had not previously received a tetanus vaccine and whose foot was punctured by a nail. They were told that he was given a tetanus antiserum injection at the hospital and

asked to suggest why this was done instead of giving him a vaccine. Candidates were expected to state that *the antiserum injection contains ready-made antibodies but the vaccine would take longer to work because it contains weakened pathogens which would first have to stimulate the lymphocytes to produce the specific antibodies required to recognize and destroy the pathogens.*

### Question 6

This question tested candidates' ability to describe the process of genetic engineering and their knowledge of the advantages of using the technology to produce insulin, and how the technology differs from artificial selection (SO C 5.2, 6.1 and 6.2). Candidates performed below expectations, earning scores from 0 to 14 out of 15. The mean mark was 2.

In Part (a), candidates were asked to describe how genetic engineering is used to produce human insulin using the bacterium *E. coli*. Few candidates seemed to be familiar with the process and only defined genetic engineering as a process whereby the genes of the organism are altered. Candidates were expected to describe how *the insulin gene/desired gene is isolated from human DNA/pancreas cells with the use of specific enzymes/restriction endonucleases and then inserted into a vector/plasmid taken from the E. coli. The altered vector/plasmid is then introduced into the E. coli and the desired gene is inserted into the organisms' DNA/genome. The genetically altered E. coli will then express the insulin gene/produce significant amounts of insulin when it reproduces. The insulin is then extracted and purified for use by humans.*

In Part (b), candidates were required to discuss three differences between genetic engineering and artificial selection used by farmers to produce improved varieties of crop plants. Some candidates were awarded full marks for explaining differences such as the following:

- *Artificial selection takes a longer time for the desired results to be seen but with genetic engineering the desired result is seen as soon as the gene is introduced.*
- *Artificial selection is carried out in a field/on a farm while genetic engineering must be carried out in a special controlled environment such as in a laboratory.*
- *Artificial selection is cheaper because genetic engineering requires more financial and technical resources as well as specialized equipment.*
- *Artificial selection involves using the whole organism/reproductive parts/gametes but genetic engineering is performed at the cellular level.*
- *Artificial selection is performed when a breeder/farmer crosses/mates a plant/animal with another of the same or closely related species but with genetic engineering the desired genes from an unrelated species are introduced into another for rapid cloning to take place.*
- *Artificial selection is labour intensive because several backcrosses are required to remove desired traits.*

- *With artificial selection a mixture of desirable and undesirable traits may be introduced to the offspring, but with genetic engineering it is easier to target only desired traits.*
- *Artificial selection involves the selection of genes for traits which already exist among the species but with genetic engineering new genes can be introduced to a species for production.*
- *Artificial selection is not harmful to humans but genetic engineering may be harmful to humans.*
- *Artificial selection has no long-term harmful effects but the long-term effects of genetic engineering are not yet known.*

Most candidates were able to suggest at least two of the three advantages of using genetic engineering to produce insulin in responding to Part (b) (ii). Advantages which were correct included the following:

- *Genetically modified bacteria are able to produce insulin within a shorter time*
- *A larger amount of insulin is produced as bacteria reproduce more frequently than other sources of insulin like pigs and cows*
- *Mass production of genetically engineered insulin is cheaper for the consumer*
- *Humans do not develop resistance to genetically engineered insulin as they do to pig or cow insulin*
- *Genetically engineered insulin from bacteria is less likely to cause allergic responses in humans*
- *Genetically engineered insulin from bacteria may be more acceptable to individuals from different religious groups, such as Muslims and Hindus, that do not use the products of pigs and cows.*

### **Paper 032 – Alternative to SBA**

This paper consisted of three compulsory questions that assessed *all* of the practical skills required of biology students. Candidates continue to display weak practical skills especially in drawings, planning and designing feasible methods for experiments that investigate biological phenomena, writing hypotheses, identifying precautions, interpreting data and writing conclusions. These observations suggest that many candidates *did not have the practical experience required to develop these skills*. These skills would also enable them to design experiments and manipulate experimental data on their own.

#### Question 1

This question examined candidates' practical skills in reporting data and required them to construct a table to present the results of an experiment, plan and design an experimental procedure to confirm the presence of carbon dioxide, write the aim of an experiment and identify precautions. It also tested their ability to apply their knowledge of aerobic and

anaerobic respiration. Candidates did not perform as well as expected on the question. They scored marks ranging from 0 to 20 out of a total of 21 marks.

Candidates were given a sample of sucrose solution and yeast suspension and instructed to measure and pour 1 cm<sup>3</sup> of the sucrose solution into each of three test tubes. They were then to add yeast suspension to each using a Pasteur pipette and were then to insert each test tube into a boiling tube. They were then told to invert the boiling tube and record the starting height of the air bubble at the top of the inverted test tube and record that measurement as the starting height of the air bubble, in mm. Each of the boiling tubes containing the inverted test tube of sucrose and yeast mixture was then to be placed for 15 minutes in a separate beaker: one containing ice at 0 °C, one containing water at room temperature and the third containing boiling water.

In Part (a) (i), candidates were required to construct an appropriate table to record the results of the experiment. This was poorly done by most candidates. In many responses, it was observed that a title was not stated and column and row headings often did not include units. In many cases, candidates inserted the units beside each measurement instead of including it once in the column or row heading.

An example of the table that candidates were expected to construct is given below.

Temperature (°C)	Height of Air Bubble (mm)	
	Initial height	Final height
0	0.3	0.3
23 ( <i>Room temperature should be stated.</i> )	0.5	1.0
100	0.3	0.3

Table showing the height of the air bubble before and after 15 minutes within the inverted test tube kept at each temperature

In Part (b) (i), candidates were required to calculate the amount of gas produced in each test tube and show their working. Most candidates were able to accurately calculate the difference between the initial and the final height of the air bubble after 15 minutes but it was observed that some candidates did not use the values that they stated in their tables in response to Part (a).

Part (b) (ii) was well done by some candidates who carefully read the information given at the beginning of the questions and realized that *the yeast was breaking down the sugar to produce energy by respiration*. Some good candidates also explained that there was *little or no oxygen in the mixture because the tube was inverted and air was unable to get in, so the yeast was respiring anaerobically/carrying out fermentation*. These candidates were also able to correctly name the gas produced as carbon dioxide in response to Part (b) (iii). However, only a few candidates were able to describe a suitable procedure to confirm that

carbon dioxide was produced as required, in responding to Part (b) (iv). Candidates were expected to state that they would *remove the test tube leaving the reaction mixture in the boiling tube but quickly cover the test tube to collect the gas and quickly add lime water to the tube. If a milky white suspension is produced then that confirms the presence of carbon dioxide.*

Part (b) (v) was challenging for many candidates. Candidates were required to explain why the amount of gas produced in each test tube was different. They were expected to explain that *the yeast enzymes involved in respiration are affected by the temperature of the mixture. At 0 °C, the enzymes were inactive so no gas was produced, but at room temperature the enzymes were able to work optimally/ferment the sugar. At boiling temperature (or 100 °C), the enzymes may have been denatured so little or no gas was produced.*

Several candidates were able to use the information given at the beginning of the question to suggest a suitable aim for the experiment in response to Part (b) (vi). An example of a well written aim is given below.

*To investigate the effect of temperature on the rate of respiration by yeast.*

Candidates who gave a response which was deemed an observation, for example, *Yeast respire faster at room temperature*, were not awarded the mark.

Most candidates were able to identify at least one precaution to be taken to prevent errors in this experiment in response to Part (b) (vii). Good candidate responses included the following:

- *Ensure that the same amount of sucrose solution is used in each test tube.*
- *Ensure that the same amount of yeast suspension is used in each test tube.*
- *Ensure that equal time is allowed for the reaction to take place at each temperature.*
- *Ensure that the temperature is maintained for the time allowed for the reaction.*

## Question 2

In this question, candidates' ability to plan and design an investigation to determine the end products of photosynthesis was assessed (SO B 2.2 and 6.3). They were also required to use their planning and designing skills to modify the experiment to investigate the effect of light and the effect of an oil spill on the rate of photosynthesis. Candidates performed poorly on this question. They earned scores ranging from 0 to 22 out of 24 marks.

Candidates were given diagrams of equipment and materials to be used in setting up the experiment to collect both end products of photosynthesis. In Part (a), they were instructed to draw a diagram to illustrate how the apparatus could be set up to conduct the experiment. Candidates who were familiar with how to set up the apparatus for

investigating photosynthesis in an aquatic plant were able to produce a fairly accurate diagram as shown below.

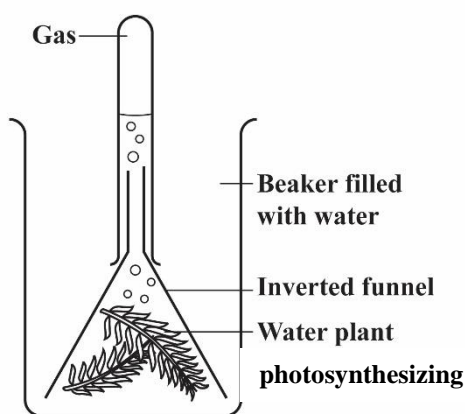

The light source should be placed either to the left or the right of the apparatus so that the plant is able to get the maximum amount of light.

In Part (b), candidates were required to write a balanced equation for the process of photosynthesis. This was well done by most candidates, but a few candidates lost a mark because they did not produce balanced equations even though the names of the reactants and products were correct.

In Part (c), candidates were asked to describe the procedure that could be used to determine the presence of each of the end products. Several candidates were able to accurately describe how they would test for oxygen using a glowing splint inserted into a boiling tube containing the gas. They also mentioned that *the splint relights if oxygen is present*.

The procedure to test for the presence of starch was also well known by most candidates. They were able to explain that they would *put iodine solution on the leaves of the plant and mentioned that a blue-black colour would be observed if starch is present*. Very few candidates also said they would *boil the leaves in a water bath then gently heat the leaves in ethanol to remove chlorophyll before putting the iodine solution on the leaves to test for starch*.

Part (d) was challenging for some candidates. Candidates were asked to describe how the apparatus may be modified to investigate the effect of light intensity on the rate of photosynthesis. They were expected to explain that they would *place the light source at different distances from the photosynthesizing plant and count the number of bubbles produced for each distance*. Some candidates explained that they would set up the apparatus in different rooms having different light intensities and were awarded marks.

In Part (e), candidates were required to describe how the apparatus could also be modified to determine the effect of an oil spill on the rate of photosynthesis. Most candidates correctly stated that they would *add a layer of oil onto the surface of the water or bicarbonate solution into which the pond weed was placed*. However, few candidates also mentioned that they would *direct the light source towards the pond weed from above the surface of the layer of oil*.

Candidates were expected to use their knowledge of the properties of oil and the process of photosynthesis to explain the effect of oil on the rate of photosynthesis, in responding to Part (f). The following is an example of a good candidate response:

*The oil will prevent the water plant from absorbing sufficient sunlight needed for photosynthesis. It will block the sunlight or light and this would result in the lowering of the rate of photosynthesis.*

For Part (g), most candidates were awarded one of the two marks allotted for describing two possible controls for the experiment—*placing the apparatus in a dark room or covering it to block light from reaching the pond weed*. Another suitable control would be to *use a pond plant that was boiled*.

In Part (h), candidates were told that a beaker of water is inserted between the light source and the experiment. They were then asked to explain why this was an appropriate precaution. Most candidates found this question challenging. Candidates were expected to explain that *the beaker of water will absorb the heat from the light source and so the temperature would be maintained which would prevent heating of the water/solution and slow down photosynthesis by the plant*.

Part (i) was also challenging for most candidates. This question required that candidates state one possible source of error. Expected responses included the following:

- *Not counting the bubbles produced accurately*
- *Using water/bicarbonate solution that was at a temperature that would denature the enzymes in the plant*
- *Plant that was already dead because it was sprayed with herbicide*

### Question 3

This question tested candidates' understanding of types of variation among humans using a continuous variable, height and a discontinuous variable, type of ear lobe (SO C3.3). Candidates' performance was satisfactory, with scores ranging from 0 to the maximum of 15 marks allotted for the question.

Candidates were told that some students chose to measure the height and count the number of free versus attached ear lobes of males in their class, while investigating types of variation in humans.

In Part (a), they were required to plot a histogram of the height data and a bar chart to represent the frequency of ear lobe types observed. This was well done by most candidates but a few were unable to get full marks because the legend on the y-axis labelled height did not include the units, cm.

In Part (a) (ii), candidates were required to suggest two precautions to be taken by the students when measuring the height of each individual. This was also well done by most candidates. Good responses included the following:

- *Measuring heights with shoes off*
- *Ensuring individuals are standing straight*
- *Reading the ruler/measurement at eye level*

Most candidates got at least one of the two marks allotted in Part (a) (iii) for their explanation of the difference in the distribution pattern of each of the characteristics investigated. The expected response was that *height is determined by genes inherited from parents as well as the environment, such as getting sufficient energy to support growth from the diet, while earlobe attachment is determined only by genes.*

In Part (a) (iv), candidates were asked to write a conclusion that could be drawn from the data represented on the graphs plotted in Part (a) (i). Most candidates were awarded at least one of the two marks for stating that *height varies continuously*. Some candidates also said that height is normally distributed in the population. With respect to earlobe attachment, a few candidates were able to conclude that *earlobe attachment varies discontinuously or that free earlobed persons are more prevalent in the population.*

In Part (b), candidates were required to give an example of a trait that has a similar distribution pattern to (i) height and (ii) earlobe attachment. Most candidates correctly said *weight, finger length, foot size*, in response to Part (b) (i), but few candidates were able to name examples such as *tongue rolling, blood types* for Part (b) (ii).



**CARIBBEAN EXAMINATION COUNCIL**

**REPORT ON CANDIDATES' WORK IN THE  
CARIBBEAN SECONDARY EDUCATION CERTIFICATE®  
EXAMINATION**

**JANUARY 2018**

**BIOLOGY**

**GENERAL PROFICIENCY EXAMINATION**

## GENERAL COMMENTS

The January 2018 sitting of the CXC Biology examination consisted of three papers: Paper 01 – Multiple Choice; Paper 02 – Structured/Extended Essay paper and Paper 03/2, the Alternative to the SBA.

There were significant improvements in the overall performance of candidates this year compared to that of last year's candidates. The results suggest that candidates are giving more attention to applying their knowledge of basic biological principles in the solving of problems in preparations for the examinations. It was observed, however, that there are still some weaknesses related to a lack of knowledge about fundamental biological concepts; namely digestion and assimilation, homeostatic regulation of glucose and temperature, sexual reproduction in flowering plants and the inheritance of sex-linked conditions.

Significant improvements were also seen in candidates' experimental skills. More candidates demonstrated that they were capable of planning and designing appropriate experimental procedures for carrying out investigations as well as writing hypotheses, representing their findings using appropriate tables and graphs; drawing accurate conclusions from the results and applying their knowledge to explain their results.

The Examining Committee once again reminds candidates and teachers of Biology to make use of the subject reports posted on the CXC website as they provide detailed comments by the Examining Committee on the performance of candidates on each question. They are also encouraged to pay special attention to the model answers written by similar candidates who sat the examination.

## DETAILED COMMENTS

### Paper 01 – Multiple Choice

Paper 01 consisted of 60 multiple-choice items. Performance on this paper was better when compared to that of last year's candidates. Some of the topics about which candidates demonstrated limited knowledge and/or misconceptions were:

- the role of blood in defending the body against diseases,
- the methods of controlling each stage of the life cycle of a mosquito vector,
- the location of two alleles of a gene on homologous chromosomes
- genetic engineering

### Paper 02 – Structured Questions and Extended Essays

Paper 02 consisted of six compulsory questions, three of which were in the structured response format and three in the extended essay format.

## Question 1

This question tested specific objectives (S.O.) A1.2, 2.1. 3.7; B 2.1, 2.2 and C 5.1; as well as all three profile skill areas identified in the Biology syllabus – Knowledge/Comprehension, Use of Knowledge and Experimental Skills. Candidates' performance on this question was good. Marks were achieved across the range of 0 to 24 out of a maximum of 25 marks. The mean mark awarded was approximately 13.

Part (a) examined candidates' ability to represent data presented in the form of a table, consisting of the numbers of different named organisms on a tree, on a suitable graph. This was well done by most candidates. Candidates who did not label both axes were unable to gain full marks. Candidates should be reminded that histograms consisting of bars joined together and line graphs, are used when the data is continuous. In this case, the data were discrete since the named organisms were different from each other; so each bar should have been drawn separately.

In Part (b), candidates' ability to select and describe the use of appropriate sampling methods for the animals named in the given table was tested. Most candidates were awarded at least two of the four allotted marks for stating that they would use at least one of these methods: the capture/recapture method, line transects, set traps or use nets to catch or collect then count animals such as the lizards, caterpillars and tree frogs. A common error made by candidates was that the sampling aided by a quadrat would yield the results presented in the table.

Part (c) was well done by most candidates. However, a few candidates did not recognize that the caterpillar is a stage in the life cycle of insects which are arthropods and had the misconception that caterpillars are reptiles. Some were unaware that the tree frog was an amphibian.

Part (d) was challenging for some candidates who did not recognize that the wild pine was a plant organism. Examples of candidates' responses that were awarded full marks were:

*The wild pine is a plant and therefore uses photosynthesis to make glucose for its own consumption, therefore making it a producer; whereas the other organisms feed on other plants or animals to gain nutrients.*

*Wild pine is a producer as it makes its own food (autotrophic) while the others are consumers they are dependent on producers and other organisms to get food (heterotrophic).*

Part (e) was well done by several candidates. Most candidates were able to correctly name the relationship between the wild pine and the tree as commensalism as was required in Part (e) (i). They were also usually able to include in their description that the wild pine benefits from the relationship or uses the tree to anchor itself to get as much sunlight as possible but the tree is not harmed or receive any benefits from the relationship. Candidates who described the relationship as symbiosis or mutualism were unable to gain that mark.

In Part (e) (ii), most candidates were able to explain that the relationship between the vine and the tree was a parasitic one because unlike the wild pine, the vine caused harm to the tree while benefitting from the relationship. They were also able to tell that the vine caused the leaves of the tree to die because it blocked the sunlight from the leaves of the tree, preventing it from making its own food (photosynthesis) or by taking nutrients from the tree. Some candidates also correctly suggested that the vine takes water from the tree, thus preventing it from getting to the leaves.

Several candidates found Part (f) challenging and were unable to use the theory of natural selection to explain why the green lizards were more numerous when compared to the brown ones. An example of a candidate's response that was awarded full marks was:

*The theory of natural selection states that some organisms are better suited or adapted for an environment than others and therefore have a better chance of survival. Due to the skin colour of the green lizards, they are better camouflaged on the leaves of the tree than the brown ones. The brown ones are easily spotted by predators and eaten. This results in the green lizards' survival rate increasing and therefore they can reproduce and have similar offspring.*

## Question 2

This question tested candidates' knowledge of digestion of the various nutrients and absorption of the digested products as well as the homeostatic control of blood glucose levels (S.O. B2.8, 2.10 and 10.5). Candidates' performance on this question was generally disappointing. Although they were able to get marks ranging from 0 to 15, the mean was only 5.

The products of digestion of carbohydrates, proteins and fat were well known by most candidates in responding to Part (a). However, although several candidates were able to outline that amino acids, which are the final products of protein digestion, are transported by blood via the hepatic portal vein to the liver after absorption thru villi, very few candidates were familiar with the fact that lymph transported by the lacteals of the lymphatic system found within the villi of the intestinal cells transports the products (fatty acids) of fat digestion to the liver.

Part (c) (i) tested candidates' knowledge of the role of the pancreas in digestion. Marks were awarded for explaining that the pancreas secretes pancreatic juice which consists of enzymes (carbohydrases, proteases and lipases) to complete the digestion of any undigested food; as well as bicarbonate ions which neutralize the acidic chyme coming from the stomach. The latter provides the appropriate pH for the activity of enzymes in the small intestine.

In Part (c) (ii) candidates were asked to complete a diagram by correctly identifying the hormones involved in conversion of glucose to glycogen (hormone - insulin) and glycogen to glucose (hormone - glucagon). The names of these hormones were well known by only a few candidates. A few candidates were not awarded the mark for glucagon because it was spelt so similarly to glycogen that it was not possible to determine whether candidates could distinguish between the two terms.

In explaining the role of the liver in the homeostatic control of blood glucose in response to Part (d), only a few candidates mentioned that the liver stores excess blood sugar in the form of glycogen and is the site of breakdown (hydrolysis) of glycogen to release glucose when blood glucose levels fall below normal. No marks were awarded for mentioning the hormones involved for this part.

Several candidates found Part (e) of the question challenging. Part (e) (i) required that candidates study a graph showing the variation in the blood glucose concentration of a diabetic and a non-diabetic over a 48-hour period. Most candidates were able to identify the individual labelled A as one with diabetes but only a few were able to explain that this was because that individual had higher blood glucose levels during periods when food was not consumed or that there were very wide fluctuations in that person's blood glucose levels. Only some candidates were able to use the changes in blood glucose levels of the non-diabetic to suggest that glucose concentration for a healthy person ranges from 60 to about 135 mg/dl based on the graph. The healthy range is in fact 70- 130 mg/dl. Responses which gave only a single value were not awarded marks.

### Question 3

This question tested candidates' knowledge of the structure and functions of the alveoli and associated blood vessels; as well as the effects of smoking on the lungs and the role of a dicotyledonous leaf in gaseous exchange (S. O. B 3.3, 3.4 and 3.5). The performance on this question was satisfactory with a mean of 7 out of a possible 15 marks.

In Part (a), candidates were given a diagram of an enlarged section of a human lung. Part (a) (i) required that candidates label the structures: I – bronchioles, II – pulmonary artery, III – alveoli and IV – capillaries. Most candidates were able to label at least three of the four structures correctly. In Part (b) (ii) candidates were required to state the function of the pulmonary artery (II) and that of the capillaries (IV). It was observed that instead of stating that the pulmonary artery takes (deoxygenated) blood from the heart to the alveoli/lungs as required, many candidates just vaguely indicated that its function was to transport blood. Most candidates stated that the capillaries (IV) allow for the diffusion of carbon dioxide/oxygen (or gaseous exchange) between the blood and the air contained in the alveoli (air sac).

Part (b) tested candidates' knowledge of the impact of cigarette smoking. In Part (b) (i), most candidates gave correct responses which included: darkened lungs, tar build up in the lungs, shrunken/fewer alveoli, fewer cilia narrowed air passages, increased mucus and tumors present. Part (b) (ii) was also well done as most candidates made reference to: nonsmokers benefiting from less second-hand smoke, improved air quality, reduced air pollution, reduction in diseases such as heart attacks, cancer, bronchitis and emphysema, as benefits of placing a ban on the smoking of cigarettes in public places.

It was apparent that attention was given to the impact of smoking on the structure and function of the lung tissues. However, there was still some confusion about the impact of the different *components* of cigarette smoke on the human body.

Although the candidates generally recognized nicotine as the addictive component of cigarette smoke in response to Part (b) (iii), they did not describe the specific effects of nicotine, for example, raising blood pressure and hardening arterial walls. Instead the impact of particles and tars on the lungs were described.

Some candidates interpreted Part (c) of this question as the general adaptations of dicotyledonous leaves instead of focusing on the adaptations of individual leaves for the exchange of respiratory gases. Most were able to gain marks from stating that leaves were thin and kept moist. It should be noted that while not all dicotyledonous leaves are large, they have the total surface area of the leaf increased by various strategies. Therefore 'large surface area' and not just 'large' was an acceptable answer to this part. Other ways that a dicotyledonous leaf is adapted to carry out gaseous exchange that candidates were expected to mention included having stomata, the presence of air space/spongy mesophyll and having a moist surface.

#### Question 4

This question tested candidates' knowledge of a spinal reflex arc, the role of the skin in reducing body temperature and global warming (S.O. A6.2, 6.4; B7.6, 7.11). The question was generally not well done, although candidates were able to score marks ranging from 0 to 15. The mean mark achieved was 4.

Part (a) required that candidates describe, with the aid of a diagram, the response of an individual whose skin suddenly comes into contact with a hot surface. Several candidates either did not attempt or gave an inadequate response to this part of the question.

Candidates were expected to describe that heat impulses cause the receptors in the skin to transmit impulses by way of the sensory neurons to the relay neurons of the spinal cord. The impulses are then transmitted through motor neurons to the effector muscles in the arm, which move the body part away from the hot surface. Most candidates were able to score at least two marks for identifying that the muscle/effector would contract and cause the hand to move away from the hot surface. A common misconception was that the impulses are transmitted through the sensory neuron to the brain.

The diagrams were mainly sketches of a person grimacing as he or she touched a hot stove.

Candidates were expected to show and label the parts of a reflex arc using a simple arrow diagram similar to this:

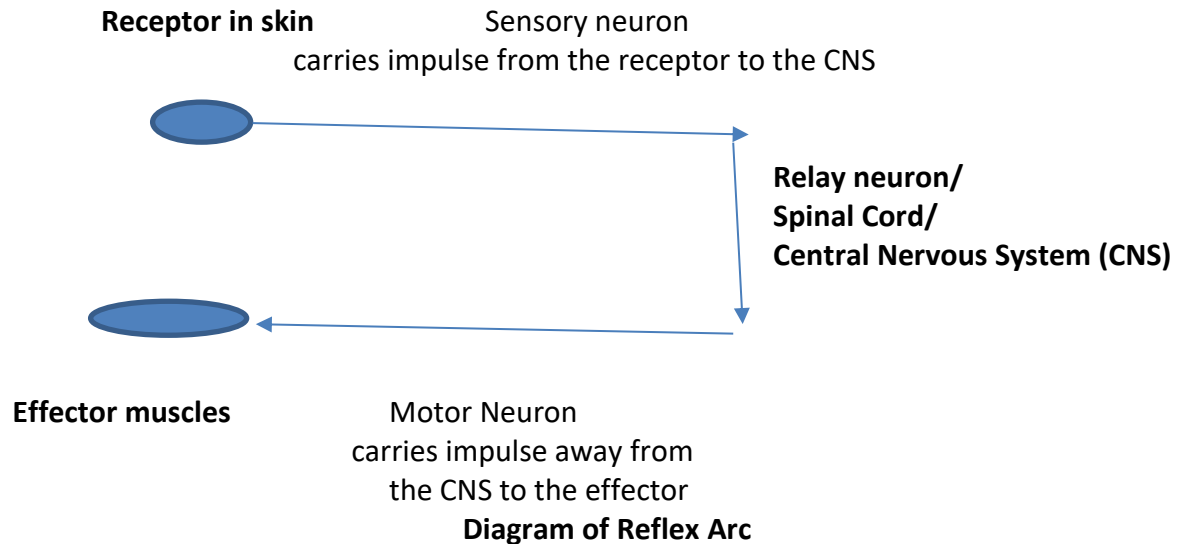

The arrows in the diagram could also be labelled to indicate the direction in which the impulses are travelling.

In Part (b), candidates were asked to explain the role of the skin in the reduction of internal body temperature and give one reason why the internal body temperature should be kept constant. Most candidates were able to earn marks for describing the sweat response as one of the ways the body gets rid of excess heat. Fewer noted that it is the evaporation of sweat that removes heat from the body. Dilation of the capillaries in the skin was only mentioned by very few candidates as a means of reducing body temperature. However, more of them were able to gain another mark for stating that when the hairs lie flat on the surface of the skin, hot air is not trapped near the skin's surface. The mark allocated to the reason for keeping internal body temperature constant was gained by most of the candidates. They correctly related temperature to enzyme activity. In fact, this was the most extensively answered part of the question.

Part (c) required knowledge of factors that contribute to global warming. Many candidates gave good answers to this part by describing human activities that lead to increased greenhouse gases such as combustion, industrialization and deforestation. Some, however, were unclear on the role of chlorofluorocarbons (CFCs) in the reduction of the ozone layer and they confused this with the increase in greenhouse gases. Most candidates gained marks for the negative impact of global warming on biodiversity by describing the loss of habitat, disruption of food webs and the risk of extinction of sensitive species. Some candidates forgot that the question was about the effect on living organisms and instead described various aspects of climate change *only*, such as melting polar ice caps, storms and flooding.

### Question 5

This question examined candidates' ability to name the types of diseases and identify examples of each type of disease, as well as their knowledge of natural and artificial immunity

(S.O. B4.6, 10.1). Performance on this question was unsatisfactory as the mean mark scored was 6.

Part (a) of this question required candidates to list three categories of diseases with an appropriate example for each. Many of the candidates did not adhere to the categories listed in the syllabus, but marks were awarded for appropriate substitutions. Candidates were expected to name the following categories and include any of the examples mentioned:

Categories of disease

- **Hereditary/genetic, non-contagious, non-communicable:** For example, sickle-cell anaemia, night blindness (cancer and diabetes were accepted).
- Nutritional deficiency, for example, scurvy, beri-beri, rickets.
- **Pathogenic/infectious/communicable/sexually transmitted disease/ contagious/transmissible,** for example, any correct viral or bacterial disease named.
- Physiological, for example, cardiovascular, diabetes, cancer, hypertension.

In Part (b), candidates were required to discuss three differences between natural immunity and artificial immunity (AI). It was observed that most candidates made reference to “innate” natural immunity and mentioned physical barriers to disease such as the skin; acid in the stomach and mucus in the gastrointestinal tract and nasopharynx. Candidates were expected to describe the role of lymphocytes (T-cells) which are able to recognize specific pathogens and mobilise other lymphocytes (B-cells) to make antibodies to attack and destroy these foreign bodies. Any two differences outlined in the table below that were discussed fully were awarded full marks. If a difference was only partially explained it was awarded one mark.

<b>Natural Immunity</b>	<b>Artificial Immunity</b>
Occurs without human (outside) intervention. Individual contracts an infection	Requires use of a vaccine/attenuated pathogen/made in a lab/medicine/Administered orally or injected
What child gets from mother in utero/breastfeeding	Uses ready-made antibodies
Lasts for a long period/lifetime	Lasts for shorter periods /requires booster/revaccination
Disease is manifested	Mild symptoms of disease may occur
No risk of side effects of vaccine	Produces other side effects which may not be related to the disease
Always works	Does not always work
May not be costly	May be expensive/costly

It was also observed that some candidates were not clear on what the term “mechanism” meant and confused artificial immunity with artificial limbs, transplants and even with digestion. Candidates were expected to explain that artificial immunity is acquired when an



individual is administered with a vaccine made from dead/weakened, strain/form of the antigen/pathogen/foreign protein. The individual's white blood cells will recognize the antigen/pathogen/foreign protein and will then cause B lymphocytes to be activated. These B lymphocytes will produce antibodies which will attack and destroy the antigen/pathogen/foreign protein. The B lymphocytes also produce memory cells that get activated to produce a fast response if the individual is exposed to the antigen/pathogen/foreign protein in the future.

### Question 6

This question tested candidates' knowledge of how meiosis contributes to genetic variation, the steps leading to fertilization in a flower, and inheritance of the sex-linked condition, haemophilia (B9.9; C2.10 and 3.1). Performance on this question was unsatisfactory as the mean mark scored was 5.

Part (a) required that candidates list two events during meiosis that lead to genetic variation among organisms. Most candidates were only awarded one of the two marks for stating that crossing over of alleles/exchange of genetic material occurs. Very few candidates also mentioned that the independent/random assortment of pairs of homologous chromosomes before the first cell division and/or the independent/random assortment of chromatids before the second cell division also lead to genetic variation. Candidates who mentioned that four genetically different gametes/cells were produced from meiosis were also awarded a mark.

In Part (b), candidates were asked to describe the process by which the male gamete reaches the female gamete in a flower. Most candidates mentioned that pollination – the transfer of pollen (containing the male gamete) from the anther where it is produced to the stigma of the flower, must first occur. Very few candidates were able to explain that a pollen tube develops and grows from the stigma, down the style and to the micropyle in the wall of the ovary of the flower. Two male nuclei, one of which is the male gamete, will travel down the pollen tube, through the micropyle and enter the ovule where the female gamete is located. The male gamete will then fuse with the female gamete (fertilization).

An example of a candidate's response that was awarded full marks was:

*The pollen grain becomes attached to the sticky stigma. A pollen tube grows downwards through the style and releases enzymes which bore the ovary and micropyle. The pollen tube attaches itself to the ovule inside the ovary. The male gamete travels from the pollen tube into the ovule where it fuses with the female gamete so fertilization occurs. A new plant is formed, the ovule becomes the seed and the ovary becomes the fruit.*

Candidates were required to use a genetic diagram to explain how a haemophiliac child could inherit the condition from parents who both have the normal clotting trait in responding to Part (c). This was poorly done by some candidates. Although most candidates were aware that this was a sex-linked condition, many did not know how to represent the alleles using the X and Y chromosomes and used only symbols to represent the alleles for haemophilia. The genetic diagram that candidates were expected to produce is as follows:

Genetic cross:

Parental genotype -  $X^H X^h$  x  $X^H Y$   
 Gametes – Female:  $X^H$  and  $X^h$  Male:  $X^H$  and  $Y$

	$X^H$	$X^h$
$X^H$	$X^H X^H$	$X^H X^h$
$Y$	$X^H Y$	$X^h Y$

Male Haemophiliac Offspring phenotype –  $X^h Y$

**Paper 032 – Alternative to the SBA**

This paper assessed the range of practical skills required of biology students and consisted of three compulsory questions. Supervisors' reports were used to guide the marking of candidates' responses where appropriate in marking Question 1. However, candidates' observations were given the benefit of the doubt for those centres where supervisors' reports were not received. Centre supervisors for practical exams are encouraged to submit their reports to facilitate an accurate assessment of their candidates' practical skills.

Candidates' overall performance on this paper was better compared to that of previous years with respect to aspects of planning and designing experiments, such as writing an aim for an experiment, using appropriate apparatus and materials and writing logically sequenced steps in designing experiments. There were also improvements seen in candidates' ability to draw correct inferences from observations, as well as in the plotting of appropriate graphs or construction of suitable tables to represent continuous or discontinuous data. Some candidates still demonstrated some difficulty with the writing of appropriate hypotheses and identifying limitations.

Question 1

This question assessed candidates' ability to test foods for the presence of different food nutrients as well as their understanding of the suitability of different foods for individuals with different physical and physiological needs (S.O. B2.6, 2.11). Candidates' performance on this question was very good as the mean mark scored was 12 and candidates scored marks across the range of 0 to 19 of the 19 marks allotted to this question.

Part (a) tested candidates' ability to perform food tests for: proteins, starch, reducing sugars and fats. Marks were awarded for identifying small amounts of reducing sugar (green or yellow with Benedict's) which should have been absent. Candidates were required to record their observations and inferences in the space provided in the table given. However, there were quite a few candidates who gave no responses and some who gave an explanation of the test in the Inference column, which suggested that these candidates might not have been familiar with what is required for an inference. It must also be noted that in most cases, the supervisors' reports received were consistent with the observations of candidates from those centres with respect to protein and reducing sugar tests. However, due to inconsistencies in the starch and fat test results of supervisors compared with those of candidates in several centres, any reasonable colour change reported by the candidates was awarded a mark and

the inference mark was awarded only if consistent with the observations stated by the candidate.

In Part (b), candidates had to hydrolyse the food sample with heat and hydrochloric acid (HCL) and re-test for starch and reducing sugars; as well as explain that the results obtained were caused by the complex, non-reducing carbohydrates being hydrolysed to reducing sugars. Marks were awarded for negative starch and positive reducing sugar. A minority of candidates were able to explain these results.

Almost all candidates were able to gain marks for Part (c), which required that candidates write an aim for the experiment. Most candidates wrote that the aim to was *to investigate the nutrients present in a sample of food*.

Candidates also performed well on Part (d) in which they selected either the teenager (who they explained requires more proteins for growth and repair; as well as carbohydrates to supply energy for an active lifestyle) or the 80-year-old diabetic, who they explained required less proteins and low carbohydrates since he/she was not as physically active and had problems controlling blood sugar. Both choices with reasonable explanations were awarded the marks.

## Question 2

This question tested candidates' planning and designing skills as well as their knowledge of transpiration in plants (S.O. B 1.7 and 4.9). Candidates' performance on this question was satisfactory with the mean mark being 11 of the 20 marks allotted to this question. Candidates scored across the range from 0 to 20 marks.

Candidates were given a list of apparatus and materials which included Coleus specie which is a plant species with transparent stem; two flasks with the same volume of dye, labelled A and B respectively; a fan, ruler and clock. In Part (a) they were required to write a suitable hypothesis for this investigation such as "*Transpiration rate is faster in windy conditions*". Candidates who wrote an aim were awarded no mark for their response.

In Part (b) candidates were required to describe a suitable procedure for investigating this hypothesis. This was well done as most candidates were wrote that they would obtain at least two similar plants of Coleus species and put at least one into each flask. One flask would be placed in front of a blowing fan while the other would be placed away from the fan in an area where there is no wind. They would then measure/record the distance travelled up the stem using the ruler, at suitable time intervals, measured using the clock.

Several candidates had a difficulty stating a limitation of this investigation. A limitation is a factor that can affect the outcome of an experiment but which is outside of the experimenter's control. Candidates were expected to say that the fan may change the air temperature or the humidity in the area around the plant. These factors may also affect the rate of transpiration.

Most candidates were able to conclude from the data presented in the table that "*Transpiration is faster in windy conditions*" as required in responding to Part (d) (i); as well

as plot the data using a line graph on the grid provided. Candidates who did not get full marks for this part of the question had a tendency to include the variable name but not the units of measurement in labelling their axes.

Part (e) was challenging for most candidates. They were expected to use their knowledge of transpiration to explain the difference in the results for the plants in Flasks A and B. Most candidates were awarded two of the four marks allotted, for stating that water vapour evaporates more quickly from the leaf surface under windy conditions and that water is pulled up more quickly to replace water lost from the leaves. Candidates were also expected to add that during windy conditions water (vapour) is carried away from the leaf surface/around the leaf surface, creating a concentration gradient which cause water (vapour) on the leaf to diffuse into the surrounding air and is replaced by water pulled up the stem.

### Question 3

This question examined candidates' knowledge of the scientific method as it applies to experiments on tropisms and taxisms (S.O. B2.2, 6.3, 7.2 and 7.4). Candidates' performance was satisfactory with the mean mark being 10 of the possible 21 marks.

Part (a) asked for hypotheses which are testable statements that seek to explain an observation. Expected were statements such as '*shoots grow towards sunlight*' and '*roots grow towards water in the soil*'. No marks were given for answers phrased as experimental aims, for example, 'to find out if...'.

In Part (b), candidates were asked to state one possible limitation of the method shown. This was poorly done, as most candidates seemed to be unaware that a limitation is a factor that can affect the outcome of an experiment but it is outside of the experimenter's control. A limitation is not the same as a precaution since any precaution would be within the experimenter's ability to control. A limitation is also not a source of error since these are only determined after an experiment has been conducted. A limitation that was accepted here was the expected difficulty in keeping only one half of the soil dry.

In Part (c), most candidates were able to gain the marks for correctly stating relevant conclusions such as '*Plant shoots grow towards light*'.

Most candidates gained the marks for correctly identifying the importance of sunlight for photosynthesis (in response to Part d) and water for photosynthesis or for keeping the plant cells turgid (in response to Part e).

Part (f) asked candidates to describe an experiment, using the choice chamber illustrated, to demonstrate the response of fly larvae to light. This part was poorly done, as very few candidates were able to gain even 3 of the possible 4 marks for this part. They were also unable to give logical limitations of the method described. Acceptable limitations were... 'the material used to make one chamber dark may affect the temperature/ humidity as well; fly larvae are in an unfamiliar environment and hence may not respond as they normally would; the experimenter may unknowingly select damaged larvae which cannot respond normally.'

Most candidates gained at least three of the five available marks for presenting the data given in a suitable table. The two marks commonly lost were for calculation of the average number of larvae in each chamber.

In Part (g), answers that described drying out or desiccation as the reason why invertebrates respond positively to moisture in the environment were given the mark. Since moist places are not necessarily dark, answers that suggested the invertebrates' need for moist environments allowed them to escape predation, were not given the mark.

**CARIBBEAN EXAMINATIONS COUNCIL**

**REPORT ON CANDIDATES' WORK IN THE  
CARIBBEAN SECONDARY EDUCATION CERTIFICATE®  
EXAMINATION**

**MAY/JUNE 2018**

**BIOLOGY**

**Copyright© 2018 Caribbean Examinations Council  
St Michael, Barbados  
All rights reserved.**

## GENERAL COMMENTS

Biology continues to be offered at both the January and June sittings of the Caribbean Secondary Education Certificate (CSEC) examinations. The Biology examination is one of the more popular of the single sciences offered by the CXC at the CSEC level and assesses the performance of about 17 585 candidates in 2018. The examination comprises four papers: Paper 01 – Multiple Choice; Paper 02 – Structured/Extended Essays; Paper 03, School-Based Assessment (SBA); and Paper 032, Alternative to School Based Assessment (offered only to private candidates).

The overall performance of candidates in 2018 was similar to that of 2017, with candidates scoring across the full range of marks in all of the questions on Paper 02. It was observed that candidates demonstrated improvement in their knowledge of fundamental biological concepts related to the structure of plant and animal cells, the structure of the eye and the respiratory system. Several candidates, however, demonstrated limited knowledge of prokaryotic/bacterial cells, the inheritance of sex-linked genes such as colour blindness and the process of cell division by mitosis. They were also challenged by their lack of understanding of important concepts related to the effect of temperature on enzyme activity, the role of epidermal guard cells in aiding water conservation by plants, plasmolysis, the consequences of the different components of cigarette smoking on human health, natural and artificial immunity and cloning — especially of animal species.

Important practical skills such as observation, recording and reporting experiments, drawing, planning and designing experiments, were lacking. The performance of several candidates on these tasks suggested that they had limited practical experience. Private candidates, in particular, are being encouraged to use the plethora of online Biology laboratory simulation experiments and activities available to enhance their practical skills if/when there is a difficulty sourcing apparatus and materials to carry out experiments described in most textbooks.

Particular attention must also be paid to the comments reiterated below in preparing candidates if the desired improvement in performance is to be realized and sustained. These comments relate both to test-taking techniques and ways of addressing the content of questions.

- Teachers should remind their students that there is more to taking an examination than memorizing the content. When preparing students for an examination, time should be spent practicing *how to interpret* and answer questions clearly, concisely and to the point.
- Candidates must improve their test-taking skills. This includes practice in reading questions carefully and planning responses so that answers are organized in a logical and cohesive manner. They should avoid, as far as possible, repeating phrases included in the question.
- Biological jargon should be used where appropriate and the *spelling* of biological terms *must* be correct. Terms that were frequently misspelt included structures associated with the human eye — sclera, ciliary muscles; structures associated with

the respiratory system — trachea and diaphragm; components of the blood — phagocytes and lymphocytes and platelets; parts of the leaf — stoma/stomata.

The examining committee suggests that teachers use more constructivist approaches in the teaching of Biology, which would get their students more involved in explaining their interpretation of biological phenomena, clarifying the content and being more fully engaged in problem-solving activities. This approach to teaching would also enhance students' ability to master knowledge of the content and critically analyse data so that they can be more effective in solving problems by gaining new insights as they think through inquiry-based activities, and to adapt what they have learned to the real world.

The examining committee also encourages Biology teachers to share best practices in the subject area and keep abreast with the rapidly changing information in the field. In addition, advanced technology is at our disposal and the timely introduction of e-learning programmes across the region is viewed as a potentially enabling opportunity. This innovation must be embraced by all as far as possible.

The examining committee also once again reminds private candidates in particular to pay careful attention to the stimulus material in each question which is meant to guide them in providing the correct responses. Teachers and candidates preparing for future examinations are also being encouraged to *review the subject reports* posted on the CXC website which have similar recommendations about the approach to the answering of Biology examination questions.

## **DETAILED COMMENTS**

### **Paper 01 – Multiple Choice**

Paper 01 consisted of 60 multiple-choice items. Performance on this paper was satisfactory and similar to that of 2017.

Some of the topics that were most problematic for candidates were enzyme activity, saprophytic nutrition, the effect of nicotine in cigarette smoke, surface area to volume ratio, transport in plants, transpiration, reflex arc, the menstrual cycle, chromosome structure, mitosis vs. meiosis, codominance as exemplified by the inheritance of blood groups and genetic engineering.

### **Paper 02 – Structured and Extended Essays**

Paper 02 consisted of six questions three of which were in the structured response format and three in the extended essay format. This paper tested all profile skill areas identified in the Biology syllabus. All questions were compulsory. Candidates' performance on this paper was similar to that of 2017. Candidates were able to gain marks across the range for all questions and the mean for almost every question was relatively close to the midpoint of the range.



### Question 1

This question was about a group of scientists who were interested in studying the survival of organisms living at high temperatures and identified some microorganisms living in a desert habitat where average daily temperatures exceeded 50 °C. Candidates were also told that a protease enzyme was extracted from the microorganisms and that the effect of temperature on the action of the enzyme was investigated. The question tested candidates' ability to identify precautions when planning and designing such an experiment, plot data collected from the experiment and presented in a table, use the data to identify the optimum temperature for the enzyme and explain the activity of the enzyme at the various temperatures. Candidates' ability to plan and design a similar experiment to investigate the effect of pH on the activity of the protease as well as their knowledge and understanding of the role of the human skin in temperature regulation and the role of epidermal cells of leaves in aiding plants to conserve water during high temperatures were also examined (Syllabus Objectives B 2.9, 4.10 and 7.11).

Although candidates were able to access marks across the full range from 0 to 25 and very few candidates scored no marks, the overall performance on this question was poor with a mean of 10.

In Part (a) (i), candidates were asked to state two precautions that they should take in carrying out an experiment to investigate the effect of temperature on the action of the enzymes extracted from microorganisms living in the desert habitat. Most candidates were able to score at least one out of the two marks.

The following precautions were expected:

- The specific temperature is maintained for each sample of enzyme/substrate mixture
- Equal amounts of enzyme/substrate mixture used
- Constant pH for all sample mixture
- Accurate reading of the thermometer
- Accurate start/stop times
- Extract the correct enzyme (protease)
- Get enzyme from same source/organism
- Accurate measurements of enzyme/substrate

Candidates who did not score marks did so because they had the misconception that the word *precaution* is limited to taking safety precautions such as the wearing of lab coats, goggles and gloves and mishandling or harming animals. Precautions are actions taken to minimize/prevent errors when conducting an experiment.

Part (a) (ii) required that candidates draw a graph to represent the scientists' results from their experiment that was presented in a table. Most candidates were able to produce well done graphs. A few candidates plotted a bar chart and in some cases the orientation of the axes was problematic although the candidates were not penalized for this. Candidates should be reminded that the factor that is determined by the person(s) being controlled in the experiment (the independent variable — temperature in this case) must be placed on

the x-axis and the factor that is being measured (the dependent variable — time taken for the substrate (which is protein in this case) to be broken down) should be placed on the y-axis.

Most candidates were able to correctly determine the optimum temperature (55 °C) of the enzyme from the graph, in response to Part (a) (iii).

Part (a) (iv) requested that candidates give reasons for the shape of the graph at different temperatures but most candidates described the shape of the graph without giving reasons and hence they were awarded no marks.

The acceptable answers were as follows:

*Below 10 °C*

Enzymes were inactive/had little or no energy to meet/react with the substrate.

*10 °C to 55/57 °C*

Enzyme activity increases/protein/substrate broken down faster/products formed faster because enzymes and/or substrate have enough (kinetic) energy to collide /react at active site.

*Above 55/57 °C*

The optimum temperature is exceeded. The enzymes' active sites are destroyed (are denatured) and enzymes can no longer bind to the substrate/break them down.

The following is an example of a candidate's response that scored full marks:

*Less than 10 °C*

The enzyme and substrate molecules have low kinetic energy since the temperature is low, and thus collision between enzyme active site and substrate is slow, as the reaction takes the longest time to be completed.

*10–55 °C*

As temperature increases, the enzyme and substrate molecules gain more kinetic energy, therefore there are more collisions between enzyme and substrate forming more enzyme-substrate complexes, so the rate of reaction increases and so takes the least time for protein to disappear as temperature increases until the optimum temperature (55 °C) where the rate of reaction is fastest.

*More than 55 °C*

These temperatures are greater than the optimum temperature and hence the enzymes are denatured as the active site is altered so substrate can no longer fit into the enzymes' active site and less products are formed so it takes the most time to disappear.

In Part (a) (v), candidates were expected to describe a suitable procedure to investigate the effect of pH on the activity of the protease enzyme.

Acceptable answers included the following:

- Enzyme/substrate mixtures contain reagents/buffer with different pH (acid, alkaline, neutral).
- The same amount (volume) of enzyme and substrate were used to carry out the experiment at each pH.
- The results of rate/time taken for the disappearance of substrate/rate of product formation at each pH are recorded/plotted/used to draw a graph.
- The temperature for all enzyme–substrate samples are kept the same.

The following is an example of a candidate's response that scored full marks:

Using samples of the same type of protein in the same amount, add these to solutions at different pH conditions in a test tube. For example, one at pH 7, one at pH 2 and one at pH 12. Then add the same amount of protease enzyme to each tube at the same time and record the time taken for the protein to disappear in each tube, ensuring that temperature is kept constant. Observations are made and results recorded and the tube which takes the least time for protein to disappear is the optimum pH for protease enzyme. A graph can be plotted (time vs. pH) to observe changes.

In Part (b) (i), candidates were asked to identify the parts of the human skin that were labelled I to IV. Candidates who had knowledge of the skin's structure were able to label Structure I as the hair/shaft, II as the sweat gland, III as the erector muscle and IV as a blood capillary. It was observed that many candidates were unable to distinguish the hair follicle from the shaft and the sweat duct from the sweat gland. Most candidates were, however, able to identify the blood capillary/arteriole and the erector (pili) muscle.

Several candidates were able to provide satisfactory responses to Part (b) (ii). Candidates were expected to describe how the structures identified helped humans to regulate their body temperature. It was observed that in some instances responses were jumbled and might have been better organized if candidates had separated the parts to be answered into activities related to hot temperatures and activities related to cold temperatures. Candidates should note that shivering was not accepted because it is a reflex response involving the skeletal muscles and not the structures in the skin.

Acceptable responses included the following:

*Cooling the body (Hot outside temperature)*

The erector muscles relax causing the hairs to lie flat on skin. Blood capillaries/blood vessels/arterioles dilate to supply more blood to skin. The sweat gland produces more sweat/sweat onto the surface of the skin and cooling takes place when the sweat evaporates.

*Heat conservation (Cold Temperature)/Warming up*

The erector muscles contract causing the hair to stand up. A layer of heat/warm air is trapped above the surface of the skin. Blood capillaries/arterioles constrict to reduce blood flow to the skin/retain heat in blood vessels. The sweat gland stops producing sweat.

In Part (c), candidates were expected to explain the *changes in the epidermal cells* of leaves to conserve water during high temperatures. This part of the question was poorly done by candidates since many of them answered generally in terms of leaf adaptations to conserve water (for example, rolling of leaves, thick waxy cuticle, having hairy leaves) rather than describing how changes in the epidermal cells conserve water.

Acceptable answers included the following:

- Epidermal cells consist of guard cells which surround openings called stomata.
- Many/more stomata are in the lower epidermis with few stomata on the upper surface/epidermis.
- Guard cells are bean shaped with thin outer cell walls and thickened inner walls to permit opening/closing of stoma.
- At high temperatures guard cells lose water causing them to get flaccid.
- Stomata close when guard cells are flaccid.
- Stomata close during the day when temperatures/transpiration rates are high.
- Epidermal cells develop a waxy cuticle which prevents water loss. (This was included since so many candidates provided 'waxy cuticles' as a response).

The following is an example of a candidate's response that scored full marks:

During high temperatures, the guard cells in the lower epidermis become flaccid to prevent water vapour from escaping as the stomatal opening closes since the transpiration rate increases with high temperatures. Thus, less water is evaporated and more water is conserved. The stomata also close during the day and open during the night instead to reduce water loss.

## Question 2

This question assessed candidates' knowledge of animal, plant and bacterial cells and their ability to explain the behaviour of plant and animal cells in solutions of different concentration of salt (Syllabus Objectives A 1.2, B 1.1, 1.2, 1.6 and 1.7).

This question was generally very well done by candidates, with the majority obtaining 50 per cent or more of the allocated marks. The mean score was eight.

In Part (a) (i), most candidates were able to identify the animal and plant cells presented as Structures A and B respectively, in Figure 3. However, many candidates identified the cell labelled C as either amoeba, unicellular or microorganism instead of as a bacterium/prokaryotic cell. Candidates should note that an amoeba is eukaryotic (contains organelles such as a nucleus), unicellular and is microscopic.

In Part (a) (ii), common structures among all three cell types were identified by most candidates. These included having a cell membrane, cytosol/cytoplasm, ribosomes and DNA. However, it was observed that some candidates indicated that the bacterial cell contained a nucleus instead of nucleoid (region where the DNA is located).

In stating the differences between Cells A and C, most candidates were able to include the presence of cell wall, pili/flagella/fimbriae and naked DNA, smaller ribosomes and the absence of organelles/nucleus in bacteria. Many candidates were unable to name the flagella/pili/fimbriae on the bacteria. 'Hair-like projections' was accepted as a difference between the animal and bacterial cell.

A few candidates used visible features in the drawing of the cell types (for example, size and shape to describe differences). These responses were not awarded marks. Candidates should note that such visible features should only be stated as the basis for distinguishing the structures if the question is expressed as follows: *Based on your observation of the drawings, state the differences ....*

Part (b) required that candidates describe three changes in the appearance of plant cells after being in a container of concentrated salt solution for one hour. Most candidates were able to show an understanding of the terms *plasmolysis* and *flaccidity* and to score marks for explaining that the cell membrane and cytoplasm (protoplasm) would be observed to shrink away from the cell wall; the cell wall would be more clearly visible/remain in place as well as the cell vacuole/organelles may appear smaller in size. Some candidates erroneously stated that the cytoplasm, rather than the cell membrane, shrinks away from the cell wall. Candidates should note that the cytoplasm and cell membrane do not separate from each other during plasmolysis and it is the cell/plasma membrane which separates from the cell wall. Several candidates were also able to identify the solution as being hypertonic and explained the movement of water out of the cell into the region of concentrated salt solution by osmosis.

While several candidates indicated that the plant cell retains its shape and size, which is true for those cells which have lignified cell walls, the mark was also awarded to candidates who stated that the cell became smaller in size. The vacuole and cytosol shrink due to loss of water, and non-lignified cells may also lose some water from the cell wall resulting in a slightly smaller cell size. (Consider, for example, the change in length of potato strips placed in hypertonic solutions.)

In Part (c), most candidates are able to state that when cells are placed in distilled water, water enters the animal cell which swells up and bursts because of the absence of a cell wall, while the plant cell becomes swollen and turgid but does not burst because of the cell wall. It was observed that some candidates had some misconceptions about the different effects of an influx of water into animal cells as opposed to plant cells. Some candidates thought that animal cells had cell walls and so would just swell up like plant cells and not burst. They did not understand the function of the cell wall in plants with respect to resisting turgor pressure and so their response for the plant cell was similar to that for the animal cell. Some candidates incorrectly said that the cell wall was selectively permeable, and the cell membrane freely permeable.

### Question 3

This question examined candidates' knowledge of the structure and function of parts of the human eye as well as the role of light sensitive cells in seeing colours in dimly lit conditions and the inheritance of colour blindness (Syllabus Objectives. B 7.9 and C 2.10). Performance

on this question was satisfactory. Candidates were able to score across the range 0-15 but the mean was 7.

Part (a) was fairly well done as candidates were able to score one to six marks for correctly identifying the letter as well as naming the structure which corresponded to the description given for parts of the eye. Most candidates were able to identify structure C — the lens, D — optic nerve; E — iris. Structure B — ciliary muscle, F — sclera/sclerotic coat, and G — retina were problematic for weaker candidates. The correct spelling of the parts of the eye continues to be a problem for many candidates.

Part (b) was also fairly well done as many candidates were able to either correctly name *rods* or *cones* as light sensitive cells in the retina.

Part (c) was also well done as some candidates related well how the cones are responsible for *seeing colours* and that they are activated *only in bright light*. These candidates were able to score at least one of the two marks.

Part (d) was poorly done as genetics continues to pose a challenge to many candidates across the region. In spite of the fact that the genotype of both parents was stated in the question, many candidates were unable to state the genotype of the gametes and show how they would randomly combine to produce offspring using the Punnett square.

The following is a candidate's response that scored full marks:

*Gametes: Male gametes X Female gametes*  
 $X^C Y - X^c X^c$

*Fertilization cross:*

<b>Gametes</b> →		
↓	$X^C$	$Y$
$X^c$	$X^c X^C$	$X^c Y$
$X^c$	$X^c X^c$	$X^c Y$

*Probability of colour-blind daughter is zero.*

Candidates are reminded to be careful when writing alleles since there must be a clear distinction between dominant (uppercase letters) and recessive (lowercase letters) alleles. Candidates were only awarded the marks if there was a *clear difference in the font size of the 'C' distinguishing the alleles*.

#### Question 4

This question examined candidate's knowledge of the respiratory system and the consequences of smoking (Syllabus Objectives B 3.3, 3.4 and 3.5). Performance was satisfactory with a mean of 7 out of 15 marks.

In Part (a), most candidates were able to gain at least four of the 6 marks for correctly labelling the diagram of the human respiratory system. The label that was commonly

incorrectly identified was the *pharynx*. Spelling continues to be a problem for the candidates.

In Part (b), candidates who interpreted the question correctly were able to gain the marks for identifying characteristics common to both respiratory surfaces and to explain why each feature is important for the exchange of respiratory gases. The features of large surface area and thinness were the most commonly cited features and these were usually linked to their roles in increasing the speed and efficiency of gas exchange across the surfaces. A few candidates noted that the both types of respiratory surfaces were kept moist. However, some candidates did not explain that moisture was needed for the gases to dissolve before movement across the respiratory surface could take place.

Part (c) (i) was fairly well done as candidates were able to demonstrate that they knew many of the components of cigarette smoke, namely carbon monoxide, tar and acrolein. However, the majority was not able to link the component with the relevant effect correctly. Since cigarette smoking is an important social issue, more attention should be paid to learning that different components have very different effects on the pathophysiology of human body systems.

Part (c) (ii) was well done as most candidates were able to correctly identify at least two out of the many effects of nicotine on the functioning of the human body. Candidates' responses included increasing heart rate, increasing blood pressure, negatively affecting brain function, causing blood platelets to clump together and promoting thickening/hardening of artery walls.

### Question 5

This question tested candidates' knowledge of the role of named components of the blood in protecting against pathogens and types of immunity against pathogenic diseases (Syllabus Objectives B 4.4, 4.5 and 4.6). Performance on this question was poor even though candidates were able to score across the range of marks, 0–15. The mean was 6.

In Part (a), candidates were expected to identify phagocytes, lymphocytes and platelets as three components of the human blood that are important in protecting the body against pathogenic diseases. This was well done by most candidates; however, it was observed that several candidates had difficulty spelling the names of the components correctly. Those candidates who said white blood cells as well as phagocytes and/or lymphocytes (which are types of white blood cells) helped to protect against these diseases were not awarded additional marks. Those candidates who named plasma proteins such as fibrinogen, globulins/antibodies as components that protect against diseases were also awarded the marks.

Candidates who also correctly identified the functions of the components they named were also awarded marks. Some candidates were unaware that phagocytes function by engulfing pathogens such as bacteria and destroying them; lymphocytes produce specific antibodies that also aid in destroying pathogens, while platelets cause blood to clot and thus prevent the entry of pathogens into the body. It should also be noted that candidates who stated that plasma and red blood cells were important in protecting the body against pathogenic

diseases were not awarded marks for naming these components but if they said that plasma protects the body by transporting other components such as antibodies of the blood that defend the body against disease or said that red blood cells carry oxygen which is used in respiration to provide energy to defend the body against pathogens, they were awarded one mark for each of these responses.

Part (b) required that candidates explain how the type of immunity a one-month baby acquired by breastfeeding differs from the type of immunity the baby's father acquired on receiving a tetanus vaccine. Several candidates were able to explain that the type of immunity shown by the baby was natural passive immunity because the baby gets antibodies from the breastmilk (passive immunity) and these antibodies were originally produced by the mother (natural immunity). However, fewer candidates were able to correctly explain that the type of the immunity shown by the father is artificial active immunity because the vaccine contains a weakened strain of the pathogen (artificial immunity) and the father's lymphocytes produce antibodies that destroy the pathogen injected (active immunity).

A few candidates also added that while the baby's immunity is temporary (since the antibodies received from her mother are removed from the baby's bloodstream after a few weeks), the father's immunity is permanent and does not need a tetanus antiserum injection which contains antibodies against the pathogen. This is because some of his lymphocytes became memory cells after the father was exposed to the weakened pathogen and this allowed the father's body to respond to the pathogen by rapidly producing antibodies to destroy it whenever he is exposed to the same pathogen again. Some misconceptions that were frequently observed among some candidates included the following:

- The baby acquired immunity from the nutrients in the breastmilk. This is not true. It is the antibodies in the breastmilk that allow the baby to get temporary immunity from pathogenic diseases.
- The type of immunity shown by the baby was inherited. This is also not true. The antibodies obtained by the baby from the breastmilk will only be in the baby's blood stream for a few days/weeks.
- The father gets both a weakened form of the pathogen and antibodies from the vaccine. This is also not true. The vaccine contains a weakened form of the pathogen but it is the father's lymphocytes that respond to the presence of the pathogens by producing the antibodies.

In Part (c), candidates were told that authorities prevent children who are not immunized from registering in public schools then asked them to suggest two reasons why some parents may have a valid concern about immunizing their children and two reasons why the authorities maintain their position on preventing the entry of unvaccinated children. Candidates were awarded marks if their explanation suggested that parents may be concerned because they think vaccines cause their children to get sick, become disabled/paralyzed or to die, or had a religious concern or concerns about the manner in which the vaccine is made, tested or given — injected. Some candidates were also awarded marks if they said that parents think that vaccinations were not safe because they believe that health professionals, especially in poor countries, reuse needles which are



contaminated. Most candidates correctly stated that the authorities maintain their position because unvaccinated children would transmit diseases to other children and teachers, making them sick and contributing to absenteeism from school or loss of productivity at work. Some candidates also said that the authorities want to prevent more persons from being sick as this would increase their medical care expenses.

### Question 6

This question assessed candidates' knowledge of the process mitosis, the advantages and disadvantages of sexual reproduction and the cloning of animal species (Syllabus Objectives B 6.6, 7.2 (i), 7.5, 7.9). Performance on this question was also poor with a mean of five, even though candidates were able to score across the full range of marks.

In Part (a), most candidates were knowledgeable about the process of mitosis. However, few candidates were able to give a clear, coherent description of the events in the order in which they occur. It was also noted that several candidates did not mention the duplication of chromosomes at the beginning of mitosis, which is a key event in producing genetically identical cells with the same number of chromosomes. Candidates were awarded marks for outlining the following important stages/events which occur sequentially during mitosis:

Interphase/Pre-prophase: Each chromosome replicates or is duplicated to form sister chromatids. These chromatids are attached to each other at the centromere. Chromosomes are visible/appear short and fat, and spindle fibres are formed.

Prophase: The nucleus/nuclear membrane disappears; chromatids attach to spindle fibres at its centromere.

Metaphase: Chromosomes line up at the equator of the spindle/centre of the cell.

Anaphase: Sister chromatids (chromosome) are pulled apart to opposite poles. Two sets of chromatids (chromosomes) are formed at the opposite ends/poles of the cell.

Telophase: Nuclear membrane reforms around each of the two sets of chromatids/chromosomes and the cell divides into two, each containing one of the nuclei.

Candidates were also awarded marks if they mentioned that the two (daughter) cells formed are genetically identical as they contain copies of the same chromosomes and/or the parent cell. A few candidates also got a mark for stating that mitosis occurs during asexual reproduction which involves a single parent and no gametes are involved in the process.

Candidates who repeated the details mentioned in the question or stated that the cell splits, that fission or cloning occurs were not awarded marks for these responses.

The following is an example of a candidate's response that was awarded full marks:

The parent cell's chromosomes begin to thicken and shorten thus becoming visible. Next, chromosomes line up along the spindle on the equator of the cell. The centromere holding the chromatids split and the chromatids move away from each other to opposite ends of the cell.

A nuclear membrane forms around each group of separated chromatids and the cell splits into form, forming two identical cells. Due to there being

no crossing over when the centromere split, the daughter cell is genetically identical to the parent cell.

Candidates were asked to outline two advantages and three disadvantages of sexual reproduction in Part (b). Several candidates correctly stated that the offspring are genetically varied and may be better adapted to the surroundings. A few responses also stated that offspring were less likely to compete for similar resources due to variation. A few candidates were awarded marks for stating that species that reproduce via sexual reproduction have less chance of extinction or that the species have a better chance of surviving because some of their offspring have a survival advantage over others. However, there was no mention that the diversity of offspring also forms the basis for evolution through natural selection.

Most candidates were able to identify at least one disadvantage of sexual reproduction. Acceptable responses: included the following:

- The process takes longer to produce offspring because male (pollen) and female flower (ovule) parts are required or external agents may be required for pollination.
- The process may result in the production of fewer offspring than asexual reproduction.
- Offspring may not inherit the beneficial traits/superior quality of parents.
- More energy is required for attracting a mate (or pollination).

It was observed that a few responses identified that offspring may have resistance to diseases as an advantage. But candidates should note that there is no guarantee that beneficial traits will be passed on from parents or appear in the offspring. Therefore, this could be considered as a disadvantage compared to asexual reproduction where all the parents' traits are passed on to offspring.

Some candidates had the misconception that mutation is a result of sexual reproduction and cited it as a disadvantage. Mutation can also occur in asexually reproducing plants.

In Part (c) (i) candidates were asked to suggest two reasons for cloning animals. Acceptable answers included the following:

- *To preserve favourable traits of an elite individual of the species, for example, resistance to disease, better quality of meat, better tolerance to environmental factors*
- *Repopulate endangered species/extinct species or a favourite pet*
- *For experimental purposes*

The following misconceptions about cloning were frequently observed in candidates' responses:

- To make many/large-scale production of clones
- To have the clone perform dangerous tasks without risking the original clones
- To increase food resources, for example, meat

- Faster process

It should be noted that the cloning of animals, unlike the cloning of plants and bacteria which reproduce asexually, is a longer process than normal sexual reproduction. The diploid ( $2n$ ) cell of the parent has to be isolated and the nucleus removed to replace the haploid nucleus of an egg cell. A few of these are then placed in a surrogate mother and develop according to the normal gestation period. It is a highly technical process which takes a longer time than normal reproduction and is much more expensive, and the success rate is low. Therefore, a reason for cloning is not to increase the population/more food or for economic purposes. Some responses indicated that it is done to improve the species. However, cloning does not involve any form of genetic improvement/engineering.

Candidates were asked to outline two ethical issues related to the cloning of humans in Part (c) (ii). Acceptable answers included the following:

- Playing God/unnatural way to procreate.
- Several embryos created which are unused and eventually destroyed — killing potential lives.
- Undermines the traditional concept of the family — offspring has only one biological parent and looks exactly like the parent ( $2n$  nucleus) and may have several parents (the egg donor, the person being cloned, the surrogate mother, the parents who do the nurturing).
- Offspring may be identical/human dignity issues.
- Selection of desirable traits suggests eugenic purpose — reduces diversity.
- May be done with malicious intent (cloning of a cruel person).
- Technology is still in its infancy — safety not yet demonstrated.
- Cloned animals shown to have shorter lifespan.
- Uncertain outcomes: environment influences gene expression and behaviours.

Misconceptions frequently observed in candidates' responses included the following:

- The clones may become a burden to society.
- Overpopulation of clones will result in a lack of resources to share for all clones who have similar needs and could lead to humans deciding to kill their clones to get resources needed.

### **Paper 032 – Alternative to School-Based Assessment**

This paper assessed most of the practical skills required of Biology students. Candidates continue to display weak practical skills especially in aspects of planning and designing including manipulating apparatus, *describing* methods of experiments, identifying limitations and drawing conclusions from data. These observations indicate that in developing practical skills candidates *must have been exposed to actually experimenting and investigating scientific phenomena, discussions, explanations and rationalizing of procedures and outcomes* so that they become capable of developing and manipulating experiments and experimental data on their own.

### Question 1

This question tested candidates' practical skills in recording observations of an investigation involving anaerobic respiration by yeast. Candidates were also required to explain the reaction observed and to design a suitable experimental control. They were also tested on their ability to identify precautions (Syllabus Objectives B 2.9, 4.10 and 7.11). Performance on the question was disappointing as the mean was 3 out of 15 marks. Candidates were able to score a maximum of 14 of the maximum 15 marks allotted to this question.

Candidates were given a test tube containing 10 ml of sugar solution prepared using boiled water which was cooled, and were instructed to add yeast then liquid paraffin and immediately cover the tube with a rubber bung containing a tube leading into a solution labelled X. In Part (a), candidates were asked to state two observations made about Solution X after 30 minutes. Several candidates demonstrated poor observation skills in responding to Part (a). Candidates were expected to state that bubbles were seen, and that a cloudy/milky suspension developed.

Part (b) required that candidates explain the reaction that took place in the yeast–sugar solution mixture that accounts for the observations in Part (a). This part was poorly done as candidates did not link the observations to the reactions. Candidates were expected to explain that yeast partially broke down the sugar and carbon dioxide was produced that turned the limewater (Solution X) cloudy. The yeast was respiring anaerobically as no oxygen was present in the tube. Some candidates illustrated the reaction using a chemical equation similar to the one below.



Part (c) asked candidates to state whether the observations would be different if the water used to prepare the sugar solution was not boiled and liquid paraffin not used. This part was also very poorly done by many candidates who could not distinguish between aerobic and anaerobic respiration. Candidates were expected to say that the results would be the same as yeast can respire aerobically if oxygen is present and carbon dioxide would still be produced. Some differences candidates could have mentioned include that the sugar would be completely broken down, more energy is produced and no alcohol would be formed.

Candidates were asked to design a suitable control for the investigation in Part (d). Several candidates did not understand the concept of a control. Candidates were expected to state that the same apparatus and materials would be used and set up in a similar manner but either no yeast or boiled yeast would be used to prove that the yeast is in fact responsible for the changes observed. Alternatively, the sugar solution could be replaced with water to demonstrate that sugar must be present for the results to be observed.

In Part (e), candidates were asked to state three precautions to be taken when setting up the control experiment to ensure that the results are accurate. Most candidates were able to score at least one mark but the link between precaution and control was problematic for several candidates.

Acceptable responses included the following:

- Using the same amount of limewater/sugar solution/paraffin as in the original investigation.
- Ensure that the tube extending from the rubber bung is immersed into Solution X.
- Ensure the rubber bung is inserted into the tube.

### Question 2

This question examined candidates' ability to conduct aspects of ecological studies by describing how they would use a line transect and calculate species frequencies using the data describing the distribution of two species of mangroves. It also tested their ability to represent data using a bar graph. Their ability to describe the use of quadrats, a suitable method for collecting and studying the distribution of birds, draw a food chain among four organisms in a swamp ecosystem and a suitable procedure for investigating the water holding capacity of a sample of soil were also assessed. Candidates' knowledge of the importance of the conservation of swamps was also examined by asking them to suggest reasons developers should/should not construct a shopping mall in the area (Syllabus Objectives A 2.1, 2.3, 3.2, 3.3 and 6.1). Performance was poor with a mean score of 10 out of a possible 25 marks. A maximum of 21 of the allotted 25 marks was scored.

Candidates were told that a group of biologists were asked to conduct an ecological study in a swamp that was to be drained and used for construction of a shopping mall. In Part (a), they were presented with a table showing the number of red and black mangrove plant species found within quadrats placed at 10 m intervals along a 100 m line transect. Part (a) (i) required that candidates describe how the line transect is set up to collect the data presented in the table. Most candidates were able to gain at least one of the three marks allotted to this part of the question for stating that they would place quadrats at 10 m intervals and count the number of organisms in each quadrat. However, many candidates did not note that the rope has to be pegged in the water and that the rope is then extended in a straight line for 100 m inland. Few candidates were familiar with the setup and use of transects in sampling organisms. Candidates were expected to state that a rope was tied and stretched 100 m inland from the water. Quadrats would have been placed at 10 m intervals along the rope and a count made of the mangrove species within the quadrats. A common misconception was that the rope is to be placed to form a square/quadrat.

Part (a) (ii) was poorly done as several candidates did not know how to calculate the species frequency of each of the mangrove species. They were expected to count the number of quadrats that contained the particular species of mangrove and divide by the total number of quadrats thrown then multiply by 100. For example:

$$\text{Red mangrove frequency} = 4 \text{ quadrats} / 10 \text{ quadrats} \times 100 = 40\%$$

About half of the candidates were still able to suggest one reason why the species frequency for red mangroves decreased after 20 m while that of black mangroves increased, in response to Part (a) (iii). Candidates correctly stated that red mangroves are adapted to survive in water/waterlogged soil or that black mangroves are better adapted to live further away from water.

In Part (b), candidates were given another table which presented the frequency of animals in the swamp and told to construct a bar chart to represent the data. Most candidates were able to produce an accurate bar graph using an appropriate scale, which included correctly labelled axes, with equally spaced bars (instead of histograms), each with the same width. Candidates are encouraged to fill the bars with patterns so that they can be clearly seen.

In Part (b) (ii), candidates were required to describe how the quadrat is used to collect data about small organisms living in the water. Some candidates correctly said that the quadrats were thrown or placed randomly and repeatedly in the water. The number of each organism within the quadrat was counted then the species frequency/density/cover was determined. Most candidates lost marks for giving vague responses similar to 'quadrats are set up in such a way as to collect data on species distribution'; or 'quadrats are used to trap the organisms'.

Part (b) (iii) required that candidates describe the method used to collect the data about birds. The majority of candidates was awarded three marks for describing a method used to trap, mark and release the birds. They also correctly mentioned that a second sample of birds are recaptured and counted. However, most candidates did not include that the average or species density is calculated.

Most candidates were knowledgeable about the concept of a food chain in responding to Part (b) (iv). However, many of them did not start the food chain with a producer. This may be attributed to candidates using the names of the organisms listed in the table; as such, mangrove oysters were incorrectly placed as the producer by most candidates. Few candidates placed the arrows in the opposite direction and constructed a terrestrial food chain for which no marks were allocated. Construction of a food web was only awarded one mark for an appropriate producer. Most candidates were able to gain one mark for constructing a food web with *at least three trophic levels* including the *arrows* showing the correct feeding relationships. Only those candidates whose food chain began with a *producer* gained both marks. An acceptable answer is shown below:

*Mangrove → Fiddler crab → Blue heron → Crocodile*

One mark was allocated for naming an appropriate producer and one mark for the correct direction of the arrow head and there were at least three organisms from the mangrove swamp.

Several candidates did not accurately describe the procedure for determining the water holding capacity of the soil as required in responding to Part (c). The responses indicated that candidates had limited knowledge of this investigation. Very few candidates were able to correctly describe a method utilizing dried soil sample placed in a filter paper in a filter funnel into which a known volume of water was poured. The water-holding capacity of the soil would be calculated by subtracting the volume of water drained from the initial volume of water poured. Acceptable answers included the following procedure:

- Dry sample by repeatedly weighing soil.
- Place filter paper in a funnel and then place the funnel in a measuring cylinder.

- The weighed sample is placed in a filter paper; a known volume of water is added to the soil, wait for all the water to pass through the soil.
- The volume of water in the measuring cylinder is subtracted from the amount added to determine the water holding capacity of soil.

The following common misconceptions were observed:

- Water-holding capacity can be determined by repeatedly drying the soil and subtracting the original weight of the soil from the final constant weight.
- Placing different types of soils in different test tubes and adding water, then waiting overnight and checking to see which sample retains more water would assist in determining the water-holding capacity of the soil.

In Part (d), candidates were asked to give a reason why biologists should and should not encourage the developer to construct a shopping mall in the area. The majority of candidates were awarded the two marks allotted to this part of the question. Their responses about why the mall should be constructed included *convenience for shopping by residents in the area, employment and tourism opportunities*; whereas *destruction of habitat and nursery for a wide range of organisms, including endangered species such as crocodiles, mangroves preventing erosion, flooding and destruction of coral reefs* were suggested for discouraging construction.

A common misconception about why the mall should not be constructed was that the soil would shift or that the soil was not suitable.

### Question 3

This question tested candidates' drawing skills and their knowledge of the structure and function of blood vessels. It also examined their ability to represent graphical data in the form of a suitably constructed table, to interpret available data to draw conclusions and suggest a suitable hypothesis/explanation for the differences observed in the number of malaria parasites in the three infected persons (Syllabus Objectives B 4.3, 4.4 and C 2.8). Candidates' performance was very poor with a mean of 7 of the 20 marks allotted.

In Part (a) (i), candidates were presented with a drawing of the external view of a blood vessel which transports blood to the heart and were asked to produce a labelled drawing of the transverse section of the blood vessel as it would appear. The drawings were generally poorly done, indicating that candidates had little to no experience with doing biological drawings. Very few were able to gain marks for labels although many candidates gained at least one mark for an appropriate title. Some candidates did not know that a vein is the type of blood vessel that transports blood to the heart of a mammal and thus gave incorrect labels.

Candidates were asked to calculate the magnification of their drawing and show how they arrived at their answer in Part (a) (ii). Candidates who answered this part of the question were able to gain at least one of the three marks allotted for calculation of the magnification of the drawing. Of note is the fact that the majority of candidates who showed how they

worked out their answer did not state the units of their measurements. Several candidates did not even attempt this part of the question, confirming their lack of familiarity with the guidelines for biological drawings.

In Part (a) (iii), candidates were asked to explain how one feature shown in the drawing makes the blood vessel suitable for carrying out its function. Those candidates who had correctly identified the type of blood vessel as a vein easily gained the two marks for this part of the question. Their responses included that the valve present prevents the backflow of blood; the large lumen allows for the return of a large amount of blood back to the heart; the walls of the blood vessel prevents less resistance to blood flow and the thin walls accommodate a large lumen. Those who had mistaken the blood vessel for an artery did not describe relevant features.

Part (b) (i) required that candidates construct a table from data presented in graphical form. This part of the question was quite well done as most candidates were able to score at least four out of the six available marks. Candidates are reminded that it is important to include units of measurement on table and graph headings.

In Part (b) (ii), most candidates were able to gain at least one out of the two possible marks for stating a conclusion that could be made from the data presented. Examples of conclusions that were awarded full marks included the following:

- *Malaria parasites multiply more in normal blood cells than in sickle cell or carrier blood.*
- *Persons with sickle cell blood type or carriers are more resistant to malaria than those with normal blood type.*

Examples of conclusions that gained only one mark are given below.

- *There were a lot more parasites in normal blood.*
- *There were fewer parasites in sickler blood.*

In Part (b) (iii), many candidates were able to earn the one mark for giving a logical reason to account for the difference in the number of malaria parasites in the different types of blood. Examples of good answers to this part of the question included the following:

- *Normal blood has optimal levels of oxygen and so has more parasites.*
- *Parasites cannot survive long in the blood of sicklers because of the low oxygen content.*



**CARIBBEAN EXAMINATIONS COUNCIL**

**REPORT ON CANDIDATES' WORK IN THE  
CARIBBEAN SECONDARY EDUCATION CERTIFICATE<sup>®</sup>  
EXAMINATION**

**JANUARY 2019**

**BIOLOGY  
GENERAL PROFICIENCY**

**Copyright © 2019 Caribbean Examinations Council  
St Michael, Barbados  
All rights reserved.**

## GENERAL COMMENTS

The January 2019 sitting of the CSEC Biology examination consisted of three papers:

- Paper 01 — Multiple Choice
- Paper 02 — Structured/Extended Essays
- Paper 032 — Alternative to School-Based Assessment (SBA)

When compared with January 2018, the mean scores for the three papers were marginally lower than in January 2019. For further comparison with January 2018, an analysis of candidate performance in the three profiles was done. This revealed an increase in the number of candidates achieving Grade A or B for Profile 1, Knowledge/Comprehension (KC). There was, however, a decline in the number of candidates who achieved similar grades for Profile 2, Use of Knowledge (UK) and Profile 3, Experimental Skills (XS). Candidates were generally able to provide information as it relates to basic biological principles, however, the ability to apply this information was lacking in many instances. Candidates and teachers should therefore not only focus on the ability to memorize content but should practice applying the memorized information through the use of questions or scenarios, which require critical analysis.

Candidates generally did not perform well on questions which focused on Experimental Skills. This was evident in their performance on Question 1 in both Papers 02 and 032. Based on the overall performance on Question 1 in Paper 032, the examining committee wishes to reiterate advice provided in previous subject reports, particularly to private candidates. Candidates are encouraged to use the plethora of online Biology laboratory simulation experiments and activities available to enhance their practical skills. This is especially important if there is difficulty sourcing apparatus and materials to carry out experiments described in Biology textbooks.

The examining committee reminds candidates and Biology teachers to make use of the subject reports posted on the CXC website as they provide detailed comments on the performance of candidates on each question. They are also encouraged to pay special attention to model answers written by candidates who sat the examination.

## DETAILED COMMENTS

### Paper 01 — Multiple Choice

Paper 01 consisted of 60 multiple-choice items. For this sitting of the Paper 01, the mean score was 35; this is marginally lower than the mean score in 2018. Some of the topics that were more problematic for candidates included the following:

- Symbiotic relationships
- Diffusion
- Relating the structure of the xylem to its function
- The structure and function of the circulatory system
- Social consequences of AIDS
- Sex-linked diseases

## Paper 02 — Structured/Extended Essays

### Question 1

This question tested Specific Objectives B 2.1, 2.2, 2.6, 2.8, 2.11 and 4.13. Additionally, the three profile skill areas — Knowledge/Comprehension, Use of Knowledge and Experimental Skills — were assessed. The question assessed candidates' knowledge of sample preparation and appropriate tests used to identify food substances such as reducing sugar, protein and starch. The uses of carbohydrates and proteins, the differences between plant and human nutrition, and the reason for starch storage in plants were also examined. Reasonable responses were obtained for each part and marks ranged from 0 to 25. The mean mark was 8.77. In some cases, candidates left out parts of the question; this lack of responses negatively contributed to the mean score.

Part (a) required candidates to outline the procedure used to prepare a sample of a meal, which could be used to carry out food tests for reducing sugar and protein. Many candidates confused the preparation for the food test with the test itself and in so doing, provided inappropriate responses.

Part (b) required candidates to complete a table to describe the procedure used to test for the presence of each food nutrient in the meal. Candidates were also required to state the expected results if the food nutrient was present. Overall, many candidates were able to complete the table, and many demonstrated reasonable knowledge of the tests used for reducing sugar, protein and starch. Part (c) was also fairly well done. The enzymes for digesting carbohydrates and proteins along with the uses of carbohydrates and proteins in the diet were well known.

Part (d) (i) required candidates to suggest two ways in which the type of nutrition carried out by green plants differs from that carried out by humans. Many candidates were able to suggest only one way in which autotrophic and heterotrophic nutrition differs; very few came up with additional comparisons. They were therefore unable to gain full marks for this part. Candidates received no marks for stating 'plants carry out autotrophic nutrition'.

Correct responses included the following:

- Plants do not need a digestive system while humans do in order to break down the complex foods ingested.
- Plants depend on energy from the sunlight to make food while humans depend on plants and/or animals as an energy source.
- Plants store their food in the form of starch while humans store glycogen.
- Plants need chlorophyll to produce their food; humans do not.

Part (d) (ii) examined candidates' knowledge of the procedure to test for the presence of starch in a leaf taken from a green plant. Candidates were required to state two key steps in the procedure. The following are acceptable steps in the procedure:

- Place leaf in boiling water.
- Remove leaf, then place in alcohol.
- Wash leaf in water.
- Spread out leaf on white tile/flat surface.
- Add a few drops of iodine/potassium iodide solution.

Part (d) (iii) required an explanation for why plants store most carbohydrates in the form of starch instead of in the form of a reducing sugar. Many candidates stated those properties of starch which

make it a good storage molecule: *large, insoluble, unreactive, does not move/transported out of cells easily, needs to be broken down to take part in reactions; does not affect the osmotic/water potential of the cell.*

Part (d) (iv) examined the reasons why it is important for plants to store starch. Suitable responses include the following:

- To provide glucose/food/energy when plants are unable to photosynthesize due to conditions of drought, low light intensity and night time
- To provide energy/nutrients for plant parts that are unable to photosynthesize, that is, parts that do not have chlorophyll, for example, roots and some stems
- To provide glucose to synthesize cellulose in non-photosynthesizing organs
- To provide a source of energy for growth in perennating organs, germinating seeds

### Question 2

This question tested Specific Objectives A 2.2, 2.3, 3.4, 6.1, 6.2, 6.5, 7.1 and C 4.2. Additionally, the two profile skill areas assessed in this question were Knowledge/Comprehension and Use of Knowledge. The question required candidates to distinguish between abiotic and biotic factors. Candidates were also examined on their ability to discuss the impact of abiotic factors on living organisms, their identification and explanation of predator-prey relationships, and their explanation of the impact of human activity on the environment. Marks ranged from 0 to 14 out of a total of 15. The mean mark was 6.76.

It was apparent that some candidates did not read Part (a) (i) carefully. Instead of giving biotic and abiotic factors that may account for the extinction of a species, they gave any factor that came to mind and so lost valuable marks. Part (a) (ii) required candidates to state two activities of humans which may negatively impact species diversity and give measures that were relevant to the activities chosen. While many candidates were able to identify the activities and the corresponding measures accurately, a few candidates misunderstood the word 'measures', so they were not awarded the marks. Acceptable answers include the following:

#### *Human Activities*

- Agricultural/industrial pollution, deforestation/quarrying, introducing invasive species, over-hunting/fishing, genetic modification, captivity of certain species, therefore mating restricted, forced interbreeding

#### *Measures*

- Change practice to organic agriculture, land use policy; reforestation, monitor entry of introduction of new species, designated hunting season, designated marine reserves; education for change in unsustainable practices, laws to be enforced

For Part (b) (i), candidates were expected to identify the predator from a graph. This was generally well done. However, Part (b) (ii) was poorly done because many candidates seemed to have misunderstood the language of the question. The instructions asked candidates to use the information provided in the graph to justify their answer to Part (b) (i). The expected reason for selecting the predator curve should have included *the initial lower numbers of predators and the increasing numbers (of predators) as the number of prey declined.*

Candidates' performance on Parts (b) (iii) and (iv) showed a fairly good understanding of predator-prey relationships.

Part (c) was generally well done, although some candidates felt that the plot with 100 seeds would have needed twice the amount of fertilizer and water. That is not necessarily so. Acceptable reasons for the lower yield obtained in the plot with the larger number of seeds would have included the following:

- Competition for space: some seedlings may become spindly/die
- Competition for light: reduced photosynthesis, poor growth/yield
- Competition for fertilizer, water, nutrients: reduced photosynthesis, poor growth/yield

### Question 3

This question tested Specific Objectives C 2.8, 3.3 and B 4.4. Additionally, the two profile skill areas assessed in this question were Knowledge/Comprehension and Use of Knowledge. The question examined candidates' knowledge of continuous and discontinuous variation. It also tested their knowledge of the cellular components of blood. Additionally, candidates were required to construct a genetic diagram to show how parents with blood groups A and B could have an offspring with blood group O. Candidates were also expected to utilize their knowledge of meiosis to explain how genetic variation occurs during sexual reproduction. Marks ranged from 0 to 15 out of a total of 15. The mean mark was 6.24.

Many candidates were unable to formulate a response to Part (a) (i), and some left it blank. Some candidates were however able to provide a logical response, for example, one candidate wrote that

the phenotype for continuous variation shows a progression in variation or it changes, for example, with height. However, with discontinuous variation the phenotypes show clear-cut differences, for example, with blood groups.

Appropriate answers would have included the following:

- Continuous: Environment affects phenotype
- Discontinuous: Less environmental effect on phenotypic expression

For Part (a) (ii), many candidates provided correct responses; however, some candidates incorrectly stated that 'continuous variation may be represented as a bar chart'.

For Part (b), many candidates were able to correctly list the characteristics for continuous and discontinuous variation. However, some candidates confused the responses for the two characteristics. For example, some candidates wrote what would have been the correct response for discontinuous variation as the response for continuous variation and vice versa.

In Part (c), many candidates did well. Candidates who did not do well in this section generally did not understand what cellular components of blood are. Acceptable responses include *red blood cells*, *white blood cells (phagocytes, lymphocytes)* and *platelets*. As an additional note, candidates should pay attention to the spelling of biological terms because many spelling errors were noted throughout the paper.

Candidates were generally able to complete the genetic cross in Part (d) and provide the genotype of the offspring. However, some candidates erroneously stated the parental genotypes as ' $X^A X^O$  &  $X^B Y^O$ ', which are only used for sex-linked characteristics.

Generally, those candidates who correctly identified the parental genotype and phenotype went on to accurately complete the genetic diagram and state the genotype for the offspring with blood group O. A concerning trend which occurred, albeit in a minority of cases, was that some candidates were unable to identify the genotype for blood group O, despite a correctly done genetic diagram.

Part (e) required candidates to suggest three events which take place during sexual reproduction and which may have led to the variation in the height of the two sisters. Many candidates made reference to the inheritance of genes/alleles/traits from either parent. A large number of candidates could not correctly state other reasons why the variation would have occurred during sexual reproduction. On the other hand, some candidates provided responses which focused solely on issues/complications which may have occurred during pregnancy or delivery despite the fact that the question required the differences to be linked to three events which occurred during sexual reproduction.

#### Question 4

This question tested Specific Objectives B 2.2, 4.3, 4.7 and 4.8. Additionally, the two profile skill areas assessed in this question were Knowledge/Comprehension and Use of Knowledge. The question examined candidates' ability to apply their knowledge of the structure and function of the circulatory system in humans. Candidates were also required to compare and contrast the structure of the xylem and the capillary. Furthermore, an understanding of the process of photosynthesis in green plants was also required, in order for candidates to craft a suitable answer. Marks ranged from 0 to 15, out of a total of 15, and the mean mark was 3.49. Many candidates demonstrated poor knowledge with regard to the circulatory system. Moreover, a few candidates gave descriptions of the respiratory system instead of the circulatory system. These errors contributed negatively to the mean score.

Part (a) (i) required a description of the pumping of deoxygenated blood from the cells in the body to the lungs, using a clearly labelled diagram. While a work of art was not required, many candidates either omitted this part of the question, produced poor diagrams, or gave incorrect labels for the diagrams they produced. On their drawings, a significant number of candidates confused the left side of the heart with the right side. As a result of these misconceptions, the written description of the process was erroneous and confusing.

One candidate produced a good drawing of the heart, accurately labelled and fully annotated. Despite this, the candidate could not provide an accurate description of how deoxygenated blood is pumped from the body to the lungs. There seemed to have been a disconnect between what was drawn and what was understood.

Part (a) (ii) was misinterpreted by many candidates, but the more discerning ones were able to answer it well. Many candidates failed to show how the structure of the arteries and veins is related to their functions. In some instances, candidates inaccurately stated that 'all veins carry deoxygenated blood, and all arteries carry oxygenated blood'. Acceptable responses would have included the following:

- Arteries — thick elastic walls; veins — thin elastic walls  
Reason: Arteries withstand high pressure blood (without bursting). Veins do not withstand high pressure.
- Arteries — a small lumen; veins — a large lumen  
Reason: Arteries maintain high pressure. Veins do not withstand high pressure blood./Veins take large volumes of blood from body cells to the heart.
- Arteries — have no valves; veins — have valves  
Reason: Arteries carry high pressure blood. Veins carry blood at low pressure./Valves keep blood moving towards organs./ Valves prevent blood from flowing backwards.

Part (b) (i) required candidates to state one similarity and one difference between the structure of a blood capillary and the structure of a xylem vessel found in the stem of a green plant. Many candidates, as in Part (a) (ii), misinterpreted the question, and completely ignored the structure of the vessels. Instead, some candidates gave elaborate descriptions of the functions of the vessels. Part (b) (ii) was well done by most candidates, as they were able to suggest one or two reasons why green plants do not need to depend on the xylem for transporting oxygen to their cells.

### Question 5

This question tested Specific Objectives B 9.6, 10.1, 10.2, 10.3, 10.4 and 10.5. Additionally, the two profile skill areas assessed were Knowledge/Comprehension and Use of Knowledge. The question examined candidates' understanding of pathogenic and hereditary diseases. Candidates were also required to describe how the mode of transmission of dengue fever differs from that of the human immunodeficiency virus (HIV). Knowledge about the immune response was also tested along with methods used to control the mosquito vector. Furthermore, candidates' knowledge about how the treatment and prevention of viral diseases differs from that of diabetes was also examined. Marks ranged from 0 to 15, out of a total of 15, and the mean score was 8.68.

Part (a) required candidates to identify whether the listed conditions were hereditary or pathogenic. Overall, this was well done, and most candidates received the full two marks. Part (b) (i) required candidates to describe how the mode of transmission of dengue fever differs from that of the HIV. Candidates were then required to use this difference and their knowledge of the immune system to suggest two reasons why John did not contract dengue fever. Many candidates were able to score at least three of the five marks for this question. The following were common misconceptions:

- There is a vaccine for dengue.
- The mosquito gets the virus without biting an infected person.
- You are more susceptible to dengue if you have AIDS.
- Your immune system must be strong to fight off dengue.

For Part (b) (ii), very few candidates knew about antiretroviral medication. Some candidates incorrectly stated that 'viral diseases may be treated with antibiotics or vaccines'. The majority of candidates stated that 'insulin is used to treat diabetes'. One candidate mentioned the medication 'glucophage' for treatment. With regard to Part (c), most candidates gained full marks by providing the methods for vector control that are common in the media, such as *getting rid of old tyres* and *cutting high grass*.

Overall, this question was well done, and candidates' responses showed that they had a good understanding of diseases.

### Question 6

This question tested Specific Objectives B 7.6, 7.7 and 7.8. Additionally, the two profile skill areas assessed were Knowledge/Comprehension and Use of Knowledge. The question examined candidates' knowledge of the functions of three major parts of the brain: cerebrum, cerebellum and medulla; the pupil reflex impulse pathway; factors that would inhibit the pupil reflex response and the physiological impact on an individual consuming an amount of alcohol which causes him to crash (short-term effects). Marks ranged from 0 to 14, out of a total of 15, and the mean score was 4.69.

For Part (a), the major functions of the three major parts were not always accurate, for example, the sensory responses of the cerebrum were confused with involuntary responses in the medulla; coordination of muscle movement/tone to maintain balance by the cerebellum was confused with voluntary skeletal muscle movement by the cerebrum. Functions of the thalamus and hypothalamus were also included as functions of these parts.

For Part (b), most candidate responses received two out of three marks for inserting the correct word(s) in the blank spaces. The missing response for the pupil, that is, *constricts/gets smaller/narrows*, proved to be the most problematic and many errors/misconceptions were noted. For example, the term *contracts* has a special meaning in Biology, and is associated with muscles; hence, it was not accepted.

For Part (c), the required explanation/conclusion for *no response to the pupil reflex test* elicited poor responses. Many candidates did not make the link with the damage/defect in various steps in the pupil reflex response pathway, and instead gave suggestions for the paramedic, such as 'check pulse, blood pressure etc.' Acceptable responses would have included the following:

- Light receptors in retina damaged
- Optic nerve/sensory neuron/relay neuron damaged
- No/slow reflexes/transmission of impulses to the coordinating centre in the brain (medulla)
- Damage to the mid brain/cerebrum/brain, part of brain responsible for visual reflexes damaged

*Damaged eye/lens* and *blindness* were also accepted. However, 'being unconscious', 'in a coma' and 'brain dead' were not accepted.

In Part (d), candidates were required to explain three physiological reasons why the consumption of excess alcohol could have caused the motorcyclist to crash.

Acceptable responses included the following:

- Poor functioning of the cerebrum: impaired judgement, memory; vision — poor cognition, unable to see well
- Poor functioning of the cerebellum: reduced muscular control/balance — unable to stay upright, steer the bike, apply the brake
- Depressed central nervous system (CNS): slow reflexes/reaction time — unable to react quickly to steer away the bike/apply brakes

## **Paper 032 — Alternative to School-Based Assessment (SBA)**

### Question 1

This question tested Specific Objectives B 8.2, 8.3 and 8.1. Additionally, the two profile skill areas assessed were use of Knowledge and Experimental Skills. The question assessed candidates' knowledge of the process of germination: the structures involved, the role of water in hydrolysing food stores and the role of the cotyledons in providing energy and nutrients to the developing embryo. Marks ranged from 0 to 16, out of a total of 18, and the mean score was 7.06.



Part (a) required candidates to carefully examine two bean seeds and draw and label the structures observed. Additionally, candidates were required to calculate the magnification of the drawing. The drawings were generally poorly represented based on the shape and proportions of all structures. Additionally, there were breaks in lines, labels pointing in all directions and overall, there was poor knowledge of the names of the features of a seed.

Part (b) was worded as follows: *The early stages of germination take place in the soil where there is little or no light for photosynthesis. How does the seedling use materials it obtains from the soil for its growth and energy needs during this time?* Having recognized that the water absorbed from the soil is used to activate enzymes and solubilize nutrients stored in the cotyledons, candidates were required to propose an aim for an experiment which supported the hypothesis that the food stored in the cotyledon is the source of energy and nutrients for the growing seedling in the period before leaves are able to photosynthesize. Candidates were required to further describe the experiment, giving the expected results and one source of error. While many candidates recognized that water was absorbed from the soil, they ignored the phrase ‘for growth and energy needs’ which would have led them to explain the role of water in germination.

Of those answering Part (a), very few linked the absorption of water to the mobilization of food stores in the cotyledon (activating enzymes for hydrolysis of food stored). A common response was ‘water and minerals were absorbed to support the growing seedling.’ No marks were awarded for this.

Having been penalized for the incorrect hypothesis in Part (b) (i), candidates were awarded marks for a reasonable aim based on the process of photosynthesis: growth of seedlings; light versus dark; absence versus presence of water. Marks were also awarded for appropriate materials and equipment, procedure, expected results and source of error relevant to the stated aim.

Many candidates were distracted by certain words in the stem like ‘photosynthesis’ and ‘seedling’ which was interpreted as a growing plant rather than a non-photosynthesizing developing embryo. Some misconceptions included the requirement for minerals from the soil for germination and that being in the soil (dark) had some relevance to photosynthesis.

## Question 2

This question tested Specific Objectives A 2.1, 2.2, 7.1; B 9.7 and 9.8. Additionally, the two profile skill areas assessed were Use of Knowledge and Experimental Skills. The question examined candidates’ ability to carry out a simple ecological study using the quadrat to determine species density. The study of living organisms in their environment, including a discussion of the factors that affect the growth and survival of populations was also examined. Candidates were expected to analyse the data given and suggest reasons why a particular species of plant was not found in some areas of the field, while the other species was unaffected. Marks ranged from 0 to 25, out of a total of 25, and the mean score was 13.45.

Part (a) (i) required candidates to describe how the quadrat could be used to determine species density. Most candidates seemed familiar with the use of a quadrat. However, some candidates merely gave a description of the quadrat as a tool rather than explain how it could be used to determine species density. Acceptable responses include:

- Area to be studied selected/marketing the area with rope and pegs.
- Quadrat thrown or placed randomly within selected area.
- Number of individuals of particular species found in the quadrat counted/recorded.
- Throw the quadrat again for a total of x times (or multiple times) and record data.

In Part (a) (ii), some candidates showed accurate calculations of the population density of the species; however, some failed to gain all the marks because they gave a figure without units. They were expected to give their answer as 12 Species A plants/m<sup>2</sup>.

Most candidates were able to suggest good reasons why no Species B plants were found in some areas of the field, which is what was required in Part (a) (iii). Some suitable responses included the following:

- The quadrat was thrown randomly.
- The soil was not suitable in those areas for Species B.
- The environment (drought/flood) is not suitable.
- Does not produce seeds that are wind dispersed.
- An individual may have harvested the plants/animals grazed in the area.
- A is an invasive species.
- B is affected by pests but not A.

Part (b) (i) examined candidates' ability to accurately draw and label a half flower. Generally, this was very well done. Occasionally, candidates gave beautiful drawings, but could not label them correctly because they had either forgotten the names of the structures, or the labels were confused.

Part (b) (ii) required candidates to list at least three features of the flower other than large petals that caused it to attract insect pollinators. Candidates were able to provide many of the required responses.

Part (c) (i) examined candidates' experimental skills in determining the size of the butterfly population in a habitat. Candidates were asked to describe two suitable methods. Most of them described the use of sweep nets and the capture-recapture method. A few candidates mentioned direct observation. With reference to Part (c) (ii), the precaution that should be taken when conducting this investigation, (avoiding the trampling or killing of the organisms during catching or counting), was articulated by many candidates.

Part (c) (iii) was also generally well done by most candidates, as they recognized that an increase in the number of predators in the area, pesticides, disease, lack of food, or natural disasters could have contributed to fewer butterflies being observed by farmers in the area.

### Question 3

This question tested Specific Objectives C 3.3 and C 2.9. Additionally, the two profile skill areas assessed were Use of Knowledge and Experimental Skills. The question examined candidates' ability to analyse data and correctly represent it graphically. Candidates were further assessed on their knowledge of continuous and discontinuous variation, along with their ability to complete a genetic diagram. Marks ranged from 0 to 17, out of a total of 17, and the mean score was 8.58.

In Part (a), candidates were provided with a table representing data obtained by a student who had investigated the variation in height of individuals living in a community. Candidates were required to use appropriate scales and axes to draw a graph of the results obtained. Some excellent graphs (line graphs and histograms) gained full marks. However, the following errors were observed:

- Axes without labels.
- Incorrect scale — too small, or not breaking the scale on x-axis.

- Points were not plotted accurately, or points were joined in a haphazard manner (zig-zag, best-fit lines, etc.).
- Interchanging the axes.

For Part (a) (ii), the correlation (if any) between attached earlobes and the ability to roll one's tongue for the individuals in the community was examined. Candidates were required to construct a table to show the following data: a sample of 50 individuals showed that 20 of them had attached earlobes and 15 of them could roll their tongues. Candidates were instructed to provide the results in two columns with the first column having the four categories observed and the second having the number of individuals in each of the four categories. Some excellent tables gained full marks. However, the following errors were observed:

- Some candidates misunderstood the words *rows/columns*.
- Inaccurate transcribing of the names of the title and categories from the stimulus.
- Failure to deduce the numbers of individuals for the missing categories (based on information contained in stimulus).

Candidates were required to utilize the data from the table in Part (a) (ii) to plot a bar chart. Some excellent bar graphs gained full marks. However, similar errors occurred here also, that is, failing to label the axes (especially the vertical), or utilization of an incorrect scale which led to small graphs.

Part (a) (iv) required candidates to explain why the data obtained for earlobes and tongue rolling could not have been represented using the type of graph that was used to represent the variation in height. Very few candidates were able to gain all three marks. Most candidates just stated that one characteristic was continuous (height) whilst the other was discontinuous (tongue rolling/ear lobes). An accompanying explanation was lacking in most instances. An example of a response which received full marks is provided below.

The data provided for tongue rolling and ear lobes may be referred to as discontinuous while the data for height is continuous. Discontinuous variation shows two distinct/discrete categories for each characteristic. As a result, the information for tongue rolling and earlobes cannot be represented using a histogram as is the case for continuous variation.

Part (b) required candidates to construct a genetic diagram to explain the results of a cross for the inheritance of eye color in fruit flies, if two flies with red eye color were mated and of a total of 20 offspring, 15 had red eyes while 5 had brown eyes. Few candidates gained full marks. Candidates failed to receive marks due to the following errors/omissions:

- Symbols used in many cases were not defined.
- Failure to use a lowercase letter to indicate the recessive brown allele.
- Lack of understanding of completing the Punnett Square (or using the lines to show the cross).
- Failure to write down the offspring phenotype to show the 3:1 (15:5) Red:Brown ratio.

**CARIBBEAN EXAMINATIONS COUNCIL**

**REPORT ON CANDIDATES' WORK IN THE  
CARIBBEAN SECONDARY EDUCATION CERTIFICATE<sup>®</sup>  
EXAMINATION**

**MAY/JUNE 2019**

**BIOLOGY  
GENERAL PROFICIENCY**

**Copyright© 2019 Caribbean Examinations Council  
St Michael, Barbados  
All rights reserved.**

## GENERAL COMMENTS

The June 2019 sitting of the CSEC Biology examination consisted of three papers: Paper 01, Multiple Choice; Paper 02, Structured/Extended Essays and Paper 032, Alternative to the School-Based Assessment.

The mean scores for the three papers were comparable with those of June 2018. With regard to performance by paper, 84.37 per cent of candidates obtained Grades I–III on Paper 01 in 2019 compared with 83.67 per cent in June 2018. For Paper 02, 59.91 per cent of candidates obtained Grades I–III in 2019 compared with 59.79 per cent in 2018. For Paper 031 (SBA), 86.52 per cent of candidates obtained Grades I–III in 2019, compared with 84.42 per cent in 2018. In Paper 032, 10.48 per cent of candidates obtained Grades I–III in 2019 compared with 4.36 in 2018.

With regard to performance on the three profiles, in Profile 1 (KC), 70.06 per cent of candidates obtained Grades A–C compared with 72.26 per cent in 2018. For Profile 2 (UK), 47.88 per cent of candidates obtained Grades A–C compared with 52.38 per cent in 2018, whereas for Profile 3, 97.23 per cent of candidates obtained Grades A–C compared with 95.89 per cent in 2018.

Overall, candidates showed that they had covered the topics and were familiar with the concepts. However, candidates are reminded of the importance of reading questions carefully in order to craft the answers that are required for each part. Candidates lost valuable marks in many instances because questions were not read carefully. For example, a question referred to the carbon cycle and candidates wrote about the water cycle; another question asked about temporary methods of contraception and candidates wrote about permanent methods.

The examining committee once again reminds candidates and teachers of Biology to make use of the subject reports posted on the CXC website as they provide detailed comments by the examining committee on the performance of candidates on each question. Candidates are also encouraged to pay special attention to the model answers written by similar candidates who sat the examination.

## DETAILED COMMENTS

### Paper 01 — Multiple Choice

Paper 01 consisted of 60 multiple-choice items. The mean score for Paper 01 was 39.28. Some of the topics that were problematic for candidates include the following:

- Cell specialization
- Transport in plants and animals
- Function of the kidneys

- Relationship between the receptor and the effector
- The structure and function of skin
- Sex-linked diseases
- Genetic engineering

## Paper 02 — Structured/Extended Essay

### Question 1

This question tested Specific Objectives B 2.5, 4.8, 4.9. Additionally, the three profile skill areas were also assessed in this question: Knowledge/Comprehension, Use of Knowledge and Experimental Skills. The question assessed candidates' knowledge of transpiration and minerals used in plant nutrition. Marks ranged from 0 to 25 and the mean mark was 12.36.

Most candidates were able to score at least two out of the four marks allocated to Part (a) (i). Candidates lost marks because they simply repeated the labels used in the stimulus material. A small percentage of candidates described the process of transpiration rather than a method for determining the rate of transpiration. Some expected responses are as follows:

- *Place the beam balance on a flat surface.*
- *Zero the balance before weighing.*
- *Record the mass of the potted plant at the start of the experiment.*
- *Weigh the potted plant at regular intervals (every hour) throughout the 12-hour period.*
- *Record the mass of the plant after each weighing.*
- *Calculate the amount of water lost.*
- *After each weighing, subtract the mass of the potted plant from the initial mass.*

Most candidates were able to obtain the one mark allocated for Part (a) (ii). However, some of them provided the following responses which did not meet the required criteria:

- Stating laboratory safety measures rather than precautions.
- Keeping the area neat.
- Changes in weather/environmental factors.
- Watering the plant every hour.
- Beam balance is working well.

Some expected responses are as follows:

- *Ensure that the beam balance is placed on a flat or level surface.*
- *Calibrate the beam balance before weighting or zero the beam balance.*

- *Wait for the pointer to stop moving before taking reading.*
- *Read off weights at eye level.*
- *Place pot in the centre of the scale pan.*
- *Allow equal time intervals between weighing.*
- *Ensure there is no water on the leaf or on the beam balance at the start of the experiment.*
- *Ensure plant is healthy (no pest or disease).*
- *Ensure polythene bag is tightly sealed.*

With regard to Part (a) (iii), candidates were generally able to recall factors which affect transpiration. However, there were several candidates who provided no response to this part.

The following responses did not receive any marks:

- Climate
- Weather
- Statements of precaution to avoid error
- Malfunctioning of the scale

Common misconceptions included the following:

- Soil type affects transpiration rate.
- The plant was sweating.

Expected responses include environmental factors such as the following:

- *Temperature*
- *Humidity*
- *Wind/wind speed*
- *Light intensity/sunlight/light*
- *Water/water supply*

Part (b) (i) was generally well done; most candidates were able to obtain at least three out of the four marks allocated. Some candidates drew bar graphs and histograms instead of the table. Others constructed tables showing differences in mass rather than actual mass. A few candidates simply numbered from zero to ten in one column and placed weight in the other. Students should be reminded by teachers of the rules for constructing tables because many of them constructed the table without the use of a ruler. In the construction of the table, it is expected that the independent variable (time) be in the left column and the dependent variable (weight) be in the right column. Moreover, many candidates did not include the units for time.

In Part b (ii), several candidates stated a specific time rather than a period. Candidates are reminded to carefully read the stimulus material. Many of them identified 6 a.m. as the time at which the highest transpiration occurred. The correct response is between *9 a.m. and 11 a.m.*

Most candidates scored between two and four marks in Part (b) (iii). Well-prepared candidates, in most cases, were able to obtain five or six marks. Many candidates described the graph instead of linking their observations of the graph to factors affecting transpiration. Many discussed the changes in the rates of transpiration. Additionally, many candidates tried to explain their observations of the graph by making the link to photosynthesis instead of transpiration.

A major misconception noted was that high humidity increased transpiration rate. Another misconception was that turgid guard cells cause the closing of stomata. Explanations for the periods 6:00 a.m. to 8:00 a.m. and 9:00 a.m. to 11:00 a.m. were more competently done than for the period 12:00 p.m. to 2:00 p.m.

The following are some of the incorrect responses given for the period 12:00 p.m. to 2:00 p.m.:

- Temperature decreased.
- Light intensity decreased.
- It was night-time.

Expected responses are as follows:

*6 a.m. to 8 a.m.*

- *The (sun) light intensity is low.*
- *Few stomata open to supply carbon dioxide for photosynthesis.*
- *Little water evaporates from leaves.*
- *Adequate water available.*
- *Humidity high.*
- *Less wind.*
- *The room temperature remains relatively cool. (It is not hot.)*

*9 a.m. to 11 a.m.*

- *The light intensity is higher.*
- *Numerous/all/most of the stomata open to supply leaves with carbon dioxide.*
- *More/most of the water evaporates at this time.*
- *Humidity low.*
- *More wind.*
- *The room temperature has increased. (It is relatively warm/hot.)*

*12 p.m. to 2 p.m.*

- *The sunlight intensity is (too) high.*



- *Plants close the stomata to prevent further water loss.*
- *No water lost.*
- *Less water available.*
- *Less wind/no wind.*
- *Excessive water loss causes stomata to close.*
- *Wilting of leaves/reduced surface area of leaves.*
- *High temperature.*
- *High humidity.*

Part (c) (i) was generally poorly done. Very few candidates obtained full marks in this question. The majority obtained either one or no marks. Many candidates defined transpiration and the function of transpiration. Additionally, many of them responded to the question by describing and referring to processes such as cohesion, adhesion, root pressure and capillary action. Several candidates alluded to diffusion being responsible for the movement of water instead of *osmosis*.

Candidates identified phloem as the transport vessel for water. Others spent time describing the structure of xylem instead of discussing how transpiration aids in movement. Some candidates described water moving from the soil to the root (instead of the roots to the leaves as required).

Expected responses are as follows:

- *Evaporation from the leaves occurs through the stomata.*
- *Water moves from cells to air spaces in the leaf by osmosis.*
- *Water evaporates from the surface of the mesophyll cells.*
- *Water moves from cell to cell down a gradient/osmosis in the leaf.*
- *In the leaf, water passes from the xylem to the mesophyll cells by osmosis.*
- *Water constantly moves from top of stem xylem to leaf xylem.*
- *Pressure at top of xylem vessels is reduced/low.*
- *Water/pressure in root/base of xylem is higher than at top of xylem.*
- *Water flows up the stem/transpiration pull.*
- *Water moves from cortex of root to xylem by osmosis.*
- *Water moves from cell to cell across the root cortex by osmosis.*
- *Water moves from root hairs to the cells of the cortex by osmosis.*
- *Transpiration pull/stream aids with the movement of water from root to leaf.*

Part (c) (ii) was very poorly done. Many candidates were not able to attain any of the two marks allocated to this question. More candidates were able to recall the function of magnesium than that of calcium. One of the most common incorrect responses for the function of magnesium was that 'chlorosis would occur if magnesium was lacking'. Another common incorrect response to both the function of magnesium and calcium was that 'growth would be affected'. Many candidates stated that both minerals were important to the soil. Regarding the function of calcium, many candidates incorrectly indicated that it

made the plants strong. Teachers are reminded to focus on plant nutrition and not only animal nutrition. Marks were allocated for stating that *magnesium is required to make chlorophyll and calcium is required to make cell walls*.

Part (c) (iii) was not well done. Some candidates were able to score one out of two marks, while many were not able to score any marks in this question. Common incorrect responses included 'proteins were used as a secondary source of energy'; 'to propagate offspring'; 'needed to feed humans'; 'make amino acids' and 'used for storage'.

Marks were allocated for responses such as *growth, to make enzymes, hormones, cell membranes, new cells, nucleic acid, DNA and chromosomes*.

## Question 2

This question tested Specific Objectives A 2.3, 3.6, 5.1, 6.4; B 2.1. Additionally, the two profile skill areas assessed in this question were Knowledge/Comprehension and Use of Knowledge.

In this question, candidates were required to understand nutrient recycling (specifically the carbon cycle); explain the role of decomposers; distinguish among heterotrophic, autotrophic and saprophytic nutrition. They were also required to demonstrate understanding of the term *greenhouse gas* and its significance. Marks ranged from 0 to 15 out of a total of 15. The mean mark awarded for this question was 6.45.

Candidates were given a diagram of the carbon cycle and, in Part (a), were asked to name four numbered processes. The processes they were asked to name were *photosynthesis, respiration* and *combustion* (burning). Two processes referred to respiration, but many candidates only received one of these two marks because they failed to recognize that decomposers also respire, releasing carbon dioxide back into the atmosphere. Moreover, many candidates misinterpreted the question and gave answers suited to the water cycle (even though the question said *diagram of the carbon cycle*).

Additionally, many candidates did not name a process (as required), but instead wrote detailed explanations of the process. Candidates are advised to read the questions carefully, to be guided by the spaces or number of lines provided for responses and the number of marks allocated for each part of a question. Candidates should also familiarize themselves with the language and terminology used on the examination paper.

More discerning candidates were able to receive four marks for this part of the question. Some candidates could not identify the process of photosynthesis from the diagram given. One reason for this could have been confusion (in the minds of candidates) between the *process* of photosynthesis and the carbon cycle, since these topics are taught in different modules.

Part (b) (i) required candidates to name one type of organism responsible for decomposing organic matter. Many candidates were able to score marks for answers such as *fungi, bacteria, mould* and

*earthworms*. A few candidates mentioned the cow; this may have occurred because they did not read the question properly.

Part (b) (ii) required candidates to explain two ways in which the type of nutrition carried out by the organism named in Part (b) (i) is different from that carried out by plants, which basically meant that candidates were asked for two differences between heterotrophic and autotrophic nutrition. Generally, candidates understood that plants carry out autotrophic nutrition and decomposers carry out heterotrophic nutrition, but many of them did not specify that decomposers feed on waste or dead organisms.

One candidate answered the question in the following manner (and received full marks):

*Plants carry out autotrophic nutrition where they use simple inorganic substances, such as carbon dioxide and water, while harnessing light from the sun to split apart water molecules to react it with carbon dioxide to produce their own food, glucose. Bacteria are decomposers which employ saprophytic nutrition. They cannot harness energy from the sun and instead break down complex substances from dead organic matter by respiration to obtain energy. Bacteria use enzymes to break down dead matter, then cycle nutrients into the environment.*

If the candidate had chosen a different decomposer, for example, the earthworm, then there would have been a slightly different answer, because the earthworm is not a saprophyte but a heterotroph. The earthworm also has a digestive tract and does not secrete enzymes to decompose organic matter.

Part (b) (iii) asked candidates to state two reasons why the type of organism named in Part (b) (i) is important in an ecosystem. An exemplary answer from a candidate who wrote about bacteria is as follows:

*Bacteria are responsible for the recycling of nutrients in the environment where they break down dead matter through enzymes and respiration to release nutrients in the soil for absorption by the roots of plants. They also remove dead, decaying matter which can become toxic from disease development if pathogens begin to thrive and multiply.*

Some candidates gained only one of the two marks allotted to this part of the question because they did not offer two reasons. While many candidates wrote about the importance of decomposers in the cycling of nutrients and minerals, many of them also mistakenly wrote about the recycling of energy in the environment.

In Part (c) (i), candidates were asked to suggest two reasons why carbon dioxide is described as a greenhouse gas. The responses to this question were very poor because a large number of candidates believed that carbon dioxide depletes the ozone layer. Many candidates wrote about CFCs even though they were specifically asked about carbon dioxide. This might have occurred because some candidates believed that carbon dioxide is a chlorofluorocarbon.

The majority of candidates seemed to have a distorted understanding of the role of carbon dioxide in trapping and re-emitting IR radiation. Many of them incorrectly wrote about carbon dioxide being the 'source' of the heat or radiation. A complete answer, given by a candidate, was as follows:

*The greenhouse effect is caused by the presence of gases in the atmosphere which trap infrared radiation which increases global temperatures. Carbon dioxide is a greenhouse gas as it prevents the escape of infrared radiation, trapping it in the atmosphere to increase the earth's temperature.*

Any two of the following reasons would have been acceptable:

- *Carbon dioxide helps to trap heat in the earth's atmosphere.*
- *Carbon dioxide reflects heat back towards earth.*
- *Carbon dioxide absorbs/traps IR radiation.*
- *Carbon dioxide re-emits IR radiation thereby warming the atmosphere.*
- *Heat, normally re-emitted as long wave radiation, is trapped by carbon dioxide.*

Part (c) (ii) asked for two strategies individuals can use to reduce the amount of carbon dioxide in the atmosphere (with reference to the carbon cycle). Candidates performed well on this part of the question. Popular responses were *reforestation* and *conversion to renewable sources of energy*, but reduction of factory emissions and recycling were also seen on many scripts.

### Question 3

This question tested Specific Objectives B 3.3, 3.5, 3.4. Additionally, the two profile skill areas assessed in this question were Knowledge/Comprehension and Use of Knowledge. The question examined candidates' knowledge of the mechanism of breathing in humans, characteristics common to gaseous exchange surfaces and the effects of smoking. Marks ranged from 0 to 15 out of a total of 15. The mean mark awarded for the question was 8.90.

Part (a) required candidates to label the diagram to identify four structures that are directly involved in breathing. Marks were awarded for correct labelling of the following: nose, mouth, trachea/windpipe, bronchus, bronchiole, alveoli/air sacs, alveolus ribs, diaphragm, lungs, intercostal muscles, ribs. Some candidates did not receive marks for this question because of the following:

- Incorrect labels for bronchi and alveoli — in some instances the structures were mixed up.
- Labelling of structures that are not directly involved in breathing.
- Labels were 'left hanging' and did not point to a structure.

In Part (b), candidates were required to state how three of the structures labelled in Part (a) function in breathing during inhalation. In many instances, a link was made between the labelled structures and the function in inhalation. Correct responses included the following:

- *Nose/mouth/trachea — allow entry of oxygen/air*
- *Trachea — contain cilia which 'sweep' or remove mucus and dirt*
- *External intercostal muscles — contract*
- *Internal intercostal muscles — relax*
- *Diaphragm — contract and flattens*
- *Alveoli/alveolus/bronchi/bronchiole/lung — permit gaseous exchange*
- *Lung — expand*
- *Rib — up and out*
- *Chest cavity — volume of chest cavity increased/pressure in chest cavity reduced*

Many incorrect responses occurred because candidates mixed up the function of the internal and external intercostal muscles and incorrectly stated the function of the diaphragm and rib during exhalation (rather than inhalation).

In Part (c), candidates were required to explain how any two features of the human lung make it an efficient respiratory surface. Candidates were required to directly link the feature with an appropriate explanation. Candidates were generally able to score at least two of the four marks on this question. Acceptable responses would have included the following:

- *Thin (one cell thick): Allows for rapid diffusion of gases*
- *Large surface area: Increases the rate of diffusion by allowing more gas molecules to cross the surface at a given time*
- *Moist: Prevents surface cells dehydrating/ dissolves oxygen to have a good supply of oxygen to maintain a concentration gradient for diffusion*
- *Close to transport/blood vessels: Facilitates the transfer/transportation of gases to and from cells in all parts of the body.*

In Part (d), candidates were required to explain how exercise and smoking may affect a person's breathing rate. In some instances, candidates correctly stated that *smoking and exercise both increase the breathing rate*. However, these responses only received two of the four marks because they failed to provide an explanation for the increase in breathing rate. Alternatively, some candidates correctly stated that *the tar in cigarette smoke causes damage to the lungs*, but they linked this to a decrease in breathing rate. Acceptable responses would have included the following:

- *Exercise increases breathing rate*  
*Explanation: Working muscles need more oxygen/repay oxygen debt/increase heart rate/heart working faster.*

- *Smoking increases breathing rate*

*Explanation: Carbon monoxide in cigarette smoke reduces oxygen supply/tar in cigarette smoke damages lung tissue thereby reducing gaseous exchange capability.*

#### Question 4

This question tested Specific Objectives C 2.4, 2.5, 2.6; 3.1, 3.2; 5.1. Additionally, the two profile skill areas assessed were Knowledge/Comprehension and Use of Knowledge. The question examined candidates' comprehension of the process of meiosis; the role of meiosis in the transmission of inheritable genetic characteristics; the emergence of genetic variation and its importance. Additionally, it assessed candidates' ability to accurately apply the concept of natural selection to a given situation.

Marks ranged from 0 to 9 out of a total of 15 and the mean mark was 2. In a significant number of scripts, candidates either made no attempt to answer the question or the answers provided showed a lack of understanding of what was asked.

Part (a) required candidates to describe two events that occur in each of the following stages of Meiosis I: Prophase I, Anaphase I and Telophase I. While some candidates' answers showed that they understood the events occurring at each stage, many of them were probably, quite understandably, taught the process of meiosis as a narrative.

Part (b) (i) required candidates to give one way in which mutation and sexual reproduction are similar and two ways in which they differ. Several misconceptions, including the following, were noted:

- Asexual reproduction and mutation are synonymous.
- Mutations are due to genetic engineering.
- Many candidates equated mutation with mitosis and sexual reproduction with meiosis, and so answered the question from that perspective (difference between mitosis and meiosis).
- Mutation was man's intervention. Many candidates limited mutation to a change in chromosome number only.
- Mutations occur in plants only while sexual reproduction occurs in humans.
- Most candidates confused mutations with cloning, artificial insemination and genetic engineering.

The statements encountered on scripts indicate that candidates' understanding of these processes is fragmentary.

Acceptable responses would have included the following:

#### *Similarity*

- *Change in the genes on the DNA*

#### *Differences*

- *Sexual reproduction requires two parents while mutation may occur in a single parent.*

- *Mutation involves changes in environmental conditions while sexual reproduction does not depend on environmental changes.*
- *Mutation may not always lead to variation; sexual reproduction always leads to variation.*
- *Mutation creates new alleles while sexual reproduction does not.*

An exemplary answer to this part is as follows:

*Both are similar as genetic differences occur at the level of the gene, thus leading to genetic variation.*

*They differ as*

*(1) variation in sexual reproduction occurs as a result of the fusing of the nuclei of male and female gametes while mutations do not involve the presence of gametes*

*(2) mutations usually occur due to exposure to some environmental factor while variation by sexual reproduction is not affected by the environment, but rather the combination of genes in the male and female gametes during fertilization*

Part (b) (ii) asked candidates to explain the difference between variation in a community and variation in a population, and to suggest one way in which diversity benefits the community. Some candidates did not approach this question from a biological perspective, but from a social studies standpoint, and so lost valuable marks in the process. Most candidates seemed to have a fairly good understanding of variation in a community and variation in a population, but some of them confused the two terms.

An exemplary answer is as follows:

*Variation in a population refers to genetic and/or physical changes in a particular species within a community. This may be caused to better allow members of the species to escape from danger. Variation in a community refers to genetic and/or physical changes in all species living in a particular habitat. This may be caused by an environmental factor such as increased temperatures.*

*Genetic diversity, such as that caused by variation in a community, reduces the chance that all species living within the habitat will die if there are adverse environmental changes.*

Part (c) required a brief explanation of how bacteria may become resistant to antibiotics. A significant number of candidates stated or implied that bacteria have an immune system and produce antibodies.

Acceptable responses would have included one or two of the following points:

- *The bacteria may mutate and become resistant to the antibiotic.*
- *The bacteria change genetically.*
- *The bacteria receive DNA from a bacterium that is already resistant to the antibiotic.*

- *The bacteria change in a way (adapt) that eliminates the effectiveness of the antibiotic.*
- *The mutated strain survives due to natural selection.*

An exemplary answer is as follows:

*In natural populations of bacteria, some members may develop a mutation which allows them antibiotic resistance. When the population is exposed to antibiotics, these mutated individuals have the selective advantage and are more likely to survive. These individuals are hence more likely to reproduce, thus allowing more members to become resistant to the antibiotics.*

### Question 5

This question tested Specific Objectives B 9.2 and 9.5. Additionally, the two profile skill areas assessed in this question were Knowledge/Comprehension and Use of Knowledge. The question was designed to assess candidates' knowledge of the human female reproductive system and their understanding of contraceptive methods. Marks ranged from 0 to 15 and the mean score was 6.22.

Part (a) tested candidates' knowledge of the location and structure of the human female reproductive system. Performance was satisfactory as most candidates were able to accurately identify the pelvic region as the location of the system and to name at least four of the organs that make up the system: the ovaries, fallopian tubes/oviducts, uterus and vagina. Some were also able to name the cervix.

Several candidates had difficulty spelling the names of important organs such as the fallopian tubes and uterus correctly. Where the uterus was described as the urethra, candidates were not awarded marks because this is a tube that transports urine from the bladder to outside the body. Some candidates also had a problem describing the uterus and it was sometimes confused with the fallopian tube which leads into it. Additionally, some candidates also had difficulty describing the location/appearance of the cervix, which is a narrow opening at the base of the uterus. Candidates who included diagrams that accurately represented the human female reproductive system were also awarded marks.

In Part (b), candidates were required to name temporary methods of preventing fertilization, ovulation and implantation. This was generally well done but many candidates were not familiar with the process of implantation. A common misconception was that implantation refers to the sperm entering the ovum. This is fertilization. Most candidates were able to identify condoms (for males or females), cervical caps and spermicides as effective methods of preventing fertilization.

Several candidates named the *contraceptive pill* as a temporary method for preventing ovulation. Candidates are being reminded that they should use the term *contraceptive pill* instead of just saying 'the pill', so as to distinguish it from other forms of medication (tablet/pill) for treating other conditions such as a headache. The intrauterine device (IUD) or coil and morning-after pill (or Plan B pills) were methods often named for preventing implantation.



It was observed that a few candidates did not pay attention to the fact that the question was asking for temporary methods. These candidates named permanent methods of contraception such as tubal ligation and vasectomies to prevent fertilization. These responses were not awarded marks.

In responding to Part (c), candidates were expected to explain how the method they named in Part (b) works. Most candidates generally demonstrated knowledge of fertilization as the process by which sperm and an ovum/egg fuse to form a zygote and explained that condoms block sperm from meeting the ova or that spermicides destroy sperm preventing them from coming in contact with ova. A few candidates were also awarded marks for stating that contraceptive pills may thicken the mucus produced by the cervix and this prevents sperm from reaching ova, preventing fertilization from taking place.

Several candidates were able to score one of the two marks allotted to Part (c), as they stated that ovulation is the release of an ovum from the ovary. However, only some candidates were able to explain that the contraceptive pill contains levels of hormone(s) oestrogen/progesterone or hormone-like substances that alter the levels of hormones naturally in the body and/or prevent ovulation by disruption of the development/production/release of the ovum. Many candidates were not awarded any marks for this part of the question. It appears that several of them were unaware that implantation occurs when the fertilized ovum, called the zygote, becomes attached/embedded in the walls of the uterus. When this happens the characteristics of the uterus change and prevent anything else from being implanted in the lining of the uterus. A common misconception was that implantation was similar to fertilization.

#### Question 6

This question tested Specific Objectives B 2.0, 2.6, 2.11 and 10.5. Additionally, the two profile skill areas assessed in this question were Knowledge/Comprehension and Use of Knowledge. The question was designed to assess candidates' knowledge of the importance of a balanced diet, the final products of digestion, the regulation of blood glucose and the control of diabetes. Marks ranged from 0 to 15 and the mean score was 5.42.

Part (a) required candidates to state the name of the final products of digestion for carbohydrates, proteins, fats/lipids. Candidates were generally able to earn at least two of the three marks allocated to this question. Correct responses are as follows:

- *Carbohydrate — glucose/simple sugar/monosaccharides/fructose*
- *Protein — amino acids*
- *Fats/lipids — fatty acids and glycerol*

Candidates are reminded that both fatty acids and glycerol are the products of fat/lipid breakdown. Additionally, some candidates incorrectly stated 'glucagon' instead of *glycerol*.

Part (b) required candidates to list three other types of nutrients in a diet that would promote the maintenance of good health. Marks were awarded for any three of the following: *vitamins, minerals,*

*water, fiber/roughage*. In Part (c) (i), candidates were required to explain how the concentration of blood glucose is kept within the normal range in a non-diabetic person both *before a carbohydrate meal* and *after a carbohydrate meal*. Correct responses are as follows:

- *Before the meal blood sugar level is low — glucagon is released from the pancreas. Glucagon causes stored glycogen to be converted to glucose/this hormone causes increase in blood glucose.*
- *After the meal blood sugar level is high — insulin is released from the pancreas. Insulin causes cells to take up glucose thus removing it from the blood/allows for the storage of glucose (as glycogen)/it leads to a decrease in blood glucose.*

This question was poorly done. Many candidates failed to complete both parts of the question. Moreover, candidates did not receive all of the allocated marks for the following reasons:

- The hormone was incorrectly listed as ‘glycogen’ rather than *glucagon*.
- The names of the hormones involved were not provided.
- Some candidates appreciated that the blood glucose concentration would rise before the meal and decrease after the meal; however, no explanations were provided to support this.

Part (c) required candidates to explain why diabetic persons are advised to limit their consumption of simple carbohydrates. Many candidates appreciated that an increase in blood glucose would lead to negative health effects and proceeded to list many of these effects, for example: *damage to the organs in the long term (eyes, kidneys, heart etc.), damage to the nerves, amputations etc.* As a result, if candidates stated two *distinct* health effects, two of the three marks were awarded. The additional mark was awarded for stating any of the other correct points listed below (1–3). Alternatively, candidates were able to receive three marks for stating any three of the following:

- *Pancreas is not functioning optimally.*
- *Diabetics may not produce enough insulin or the body cells do not respond to insulin (insulin resistance).*
- *Lack of insulin (or lack of insulin response) will raise blood glucose/will result in higher than normal blood sugar concentration when simple carbohydrates are consumed.*
- *Consistent high blood sugar leads to several health problems.*

In many instances, candidates were not able to correctly link the lack or reduction of insulin as the reason for the increase in blood glucose levels after the consumption of simple carbohydrates.

## Paper 032 — Alternative to School-Based Assessment

### Question 1

For Parts (a) (i) and (ii), candidates were required to carry out food tests on a slice of potato and a slice of cheese. Most candidates were able to score at least half of the marks allocated. Candidates had difficulty expressing colour observations. Additionally, they had difficulty distinguishing between a precipitate, emulsion, suspension and solution. In some centres, the potato contained small traces of protein. This was confirmed by the supervisor's report. In some instances, candidates were unable to relate the procedures to the respective food test. This resulted in inaccurate deductions. For example, candidates wrote 'amino acids' instead of *protein*, 'carbohydrates' instead of *starch* and 'fatty acids' instead of *fats*. For Part (a) (ii), many candidates obtained a black colour with iodine and hence deduced that cheese contained starch.

Many candidates were able to obtain the one mark allocated for the aim of the experiment. An expected response was *To determine the nutrients present in two food items*. Some candidates were unable to score the mark because the sentence did not begin with *To*. In addition, some candidates named the nutrients, that is, starch, proteins and fats while others did not name all three nutrients and therefore did not have a complete aim.

In Part (a) (iv), candidates were required to provide an appropriate conclusion for the experiment. Many of them were able to attain at least one of the two marks allocated for the conclusion of the experiment. However, some candidates did not write the conclusion based on the deductions from the investigation. Candidates require more practice in making conclusions from deductions.

Some of the conclusions were very vague: for example, 'some foods have some nutrients while others do not'.

Expected responses include the following:

- *Potato contains starch and not fats and proteins.*
- *Cheese contains proteins and fats and no starch.*

Part (a) (v) required the name of one food test which was not used in this experiment and candidates had to state the nutrient it was used to test for. This part was poorly done. Many candidates repeated the food test from the experiment and did not name the food test which was not used in the experiment. For the food test, candidates gave the names of foods, for example, bread.

Some misconceptions for the names of *food tests* were protein test, sugar test and glucose test. Food tests include *Fehling's test or Benedict's test which test for reducing sugars such as glucose or non-reducing sugars such as sucrose* and *Millon's test or the grease spot test which tests for fats or lipids*.

In Part (b) (i), candidates were provided with a list of apparatus and materials and were instructed to use the list to outline a procedure which could be used to investigate the length of time taken for seeds to germinate. Many candidates were able to score at least three out of five marks for outlining a suitable procedure to carry out the experiment. However, some candidates repeated the apparatus/materials from the stimulus given instead of designing an appropriate method. Most candidates indicated that a record of the length of the radicle or stem should be taken for a period of time when seeds germinate. The question required candidates to record the time taken for the radicle or plumule to appear. Another misconception was that light is needed for germination, thus seeds were placed by a window.

Expected responses include the following:

- *Line the wall or beaker with damp tissue paper.*
- *Place a seed between the paper and the wall of the beaker.*
- *Place seed on damp tissue paper.*
- *Add water to a depth of 1 cm to keep paper moist.*
- *Observe at regular intervals till radicle appears/plumule/young shoot/young plant for germination.*
- *Set up a control with the fourth seed.*
- *Add the time taken for the radicle to appear from each seed and divide by the number of seeds.*

Three reasons why it is important to use damp tissue paper instead of dry tissue paper in performing this experiment were required in Part (b) (ii). Many candidates received at least one out of three marks for this part. Expected responses include the following:

- *Water is needed for/to start germination.*
- *Water enters the micropyle.*
- *Water is used to activate enzymes in the cotyledon.*
- *Water initiates metabolic reactions.*
- *Water mobilizes food stores in the cotyledon.*
- *To burst/rupture testa.*
- *To remove inhibition hormones (abscisic acid)/inhibitors.*
- *To remove dormancy.*
- *To get water/ensure seed gets water/moisture.*

Some candidates described why dry paper should not be used in this experiment. Some misconceptions included the following:

- The damp paper was easier to use/lay down flat.
- Water controls temperature.
- To provide oxygen.
- For osmosis.
- Acts as a soil substitute.

In Part (b) (iii), many candidates were able to score one out of the two marks for precautions. Misconceptions included general safety precautions such as measuring at eye level and ensuring that the beakers are completely dry.

Expected responses include the following:

- *Exposure to adequate air/oxygen.*
- *Suitable temperature/warmth.*
- *Use seeds that are not physically damaged.*
- *Free from pest/disease.*
- *Use the same amount of water in each beaker.*
- *Do not cover seed with water/not too much water/not too damp.*
- *Ensure the beans are soaked.*

Part (b) (iv) required the modification of the previous investigation to determine if light affects the rate of germination of bean seeds. Candidates placed the seeds in varied light intensities and some described the expected effect of light on germination. Many candidates failed to place one set of seeds in darkness, so as to compare the time taken for germination of the seed.

In Part (c) (i), many candidates were able to gain the mark for stating that the external factor that may contribute to the bending of a growing seedling is sunlight/light. Some candidates, however, identified other factors that did not contribute to the bending of the seedlings. These included temperature, water, soil type and photosynthesis.

Part (c) (ii) required candidates to have an appreciation for the difference between the type of movement shown by a growing shoot and the type of movement shown in animals. Candidates gave the reasons for movement in plants and animals but failed to compare the type of movement in plants and animals. The following examples provide comparisons:

- *Plants show growth movement while animals show non-growth movement.*
- *Animals show part or whole movement and plants show part movement.*
- *Plants show slow movement while animals show fast movement.*
- *Plant growth movement results in an irreversible increase in size while animal movement does not cause a permanent increase in size.*
- *Plant movement is irreversible while animal movement is reversible.*

## Question 2

This question tested Specific Objectives B 2.6, 6.1, 8.2. Additionally, the two profile skill areas assessed in this question were Use of Knowledge and Experimental Skills.

This question examined candidates' practical skills with respect to ecological investigations as well as their knowledge of germination and seed dispersal. Marks ranged from 0 to 12 and the mean mark was 4. In Part (a), candidates were expected to describe a sampling method a group of Biology students could have used to estimate the distribution of four mangrove species found within a swamp they visited. Most candidates recognized that a line transect was the most appropriate method for investigating the distribution of the four mangrove species since they were found in successive areas from the water to those furthest from the water. Candidates with practical experience were also able to score full marks for describing how the line transect is set up and used.

Candidates were expected to name a rope/string or tape measure as suitable equipment for setting up the transect and to describe how it is set up by pegging it/placing it at a point within the water or close to the edge of the water, then extending it in a line to the furthest point away. The line would then be measured and marked at regular intervals and a count done to determine the number of plants belonging to each of the species that are found either touching or in the vicinity of the line within each interval. The information would then be recorded and used to calculate the species frequency or density in the area.

Candidates who stated that they would use a quadrat were not awarded a mark for the apparatus named but they were awarded marks for describing that the quadrats would be thrown randomly in the area, the number of mangrove plants counted and that this would be repeated and the data used to calculate the frequency or density of each mangrove species.

In Part (b), candidates were told that the seeds of the red mangrove begin germination while still attached to the parent plant. In Part (b) (i), they were expected to use their knowledge of the conditions needed for germination to suggest why germination begins before the seeds fall from the trees into the water. Some candidates recognized that this may have occurred because oxygen is required to support germination and more oxygen is available in the atmosphere than in the water. Candidates who suggested that the temperature is more suitable for germination or that the seeds obtained adequate moisture from the parent plant were also awarded a mark.

Part (b) (ii) required candidates to suggest two reasons why the seeds dropping into the water are useful to the life cycle of the plant. This was poorly done by most candidates. Candidates were expected to suggest that this would facilitate seed dispersal, reduce competition among the offspring as well as allow for the colonization of new areas.

In Part (c), candidates named two pieces of equipment that may be used to capture and collect small invertebrates from the shallow water in the swamp. Most candidates were able to score at least one of the two marks for this part by stating that they would use nets or jars.

### Question 3

This question tested Specific Objectives C 3.3, 2.9. Additionally, the two profile skill areas assessed in this question were Use of Knowledge and Experimental Skills. The question examined candidates' ability to analyse data and to correctly represent it graphically. Candidates were further assessed on their knowledge of continuous and discontinuous variation. Marks ranged from 0 to 15 and the mean score was 6.

In Part (a), candidates were provided with a table of results from an investigation which determined the height and blood type of ten classmates. From the results provided, candidates were required to produce a suitable aim for the investigation. Acceptable aims included the following:

- *To investigate the distribution of human traits in a small student population*
- *To determine which of the characteristics exhibit continuous or discontinuous variation*
- *To determine the differences in blood type and height in ten students (or a small student population)*

Part (b) required candidates to plot the data relating to heights. Additionally, they were instructed to label the axes and state the title of the graph. Despite this, candidates neglected to provide the axes labels and the title. Some excellent line graphs (and histograms) gained full marks. The following errors were, however, observed:

- Incorrect scales were chosen.
- Points were plotted incorrectly.
- In some instances, candidates attempted to plot both blood type and height on the graph, thus leading to an incorrect graph.

Part (b) (ii) required candidates to plot a bar graph for the data relating to blood groups. Again, candidates were instructed to label the axes and state the title of the graph. In many instances this was not done. While some excellent graphs received full marks, many candidates experienced difficulty when constructing the bar chart to depict the information. These errors occurred because candidates did not first obtain the frequencies for each blood type.

Part (c) required candidates to suggest one precaution that should be taken when measuring the height of the students. Many candidates were able to receive this mark. Common responses included the following:

- *All students should take the height measurement without shoes.*
- *The same measuring instrument should be used for all students/the units used for measurement should be consistent.*
- *Measurements should be taken at eye level.*

- *Ensure measurement does not include extravagant hairstyle.*
- *Ensure that the student is standing on a flat/level surface.*
- *Measuring instrument (tape/ruler) should be straight.*

Part (d) required candidates to state that height variation was a type of continuous variation and blood type variation was a type of discontinuous variation. Many candidates were able to state this; however, some candidates mixed up the two types.

Part (e) required one reason for the difference in the two types of variation identified in Part (d). An exemplary response is as follows:

- *The height phenotype is influenced by many genes acting additively or there is an environmental influence, whereas blood group phenotype may occur due to the inheritance of single gene pairs and it is not influenced by environment.*

In many instances, candidates simply defined/explained continuous and discontinuous variation. In these instances, candidates only received one of the two marks allocated for this question because no reason was provided for the difference between the two types.



**C A R I B B E A N E X A M I N A T I O N S C O U N C I L**

**REPORT ON CANDIDATES' WORK IN THE  
CARIBBEAN SECONDARY EDUCATION CERTIFICATE®  
EXAMINATION**

**JANUARY 2020**

**BIOLOGY  
GENERAL PROFICIENCY**

**Copyright © 2020 Caribbean Examinations Council  
St Michael, Barbados  
All rights reserved.**

## GENERAL COMMENTS

The January 2020 sitting of the CSEC Biology examination consisted of three papers:

- Paper 01 — Multiple Choice
- Paper 02 — Structured/Extended Essays
- Paper 032 — Alternative to School-Based Assessment (SBA)

With regard to performance by paper, approximately 78 per cent of candidates obtained Grades I–III on Paper 01 in 2020 compared with 74 per cent in 2019 and 80.98 per cent in 2018. On Paper 02, 51.85 per cent of candidates obtained Grades I–III in 2020 compared with 35.42 per cent in 2019 and 41.11 per cent in 2018. For Paper 031, 87.31 per cent of candidates obtained Grades I–III in 2020 compared with 86.31 per cent in 2019 and 89.82 per cent in 2018. For Paper 032, 39.08 per cent of candidates obtained Grades I–III in 2020 compared with 36.71 per cent in 2019 and 53.05 per cent in 2018.

For Profile 1 (KC), 66.73 per cent of candidates obtained Grades A–C in 2020 compared to 69.84 per cent in 2019 and 66.9 per cent in 2018. For Profile 2 (UK), 58.87 per cent of candidates obtained A–C in 2020 compared to 42.25 per cent in 2019 and 54.43 per cent in 2018. With respect to Profile 3 (XS), 89.57 per cent of candidates obtained Grades A–C in 2020, compared to 71 per cent in 2019 and 88.79 per cent in 2018.

The mean score (35.72) for Paper 01 in 2020 compared to the mean score in 2019 (35.14) and 2018, (36.04). With reference to Paper 02, the mean score for 2020 (44.10) was higher than the mean score in 2019 (38.52) and 2018 (40.21). The Paper 032 mean in 2020 (19.79) compared to the 2019 mean (19.38) but was lower than that in 2018 (22.09).

Overall, performance in 2020 was better than in 2019 but similar to that in 2018. Approximately 71 per cent of candidates obtained Grades I–III in 2020 compared to 60.2 per cent in 2019 and 70.91 per cent in 2018. When compared to 2019 and 2018, candidates performed better in Paper 02, Profile 2 (UK) and Profile 3 (UK).

As a general note, candidates experienced difficulty applying their knowledge. This is evidenced by the consistently higher scores in Profile 1 (KC) when compared to Profile 2 (UK). However, it is pleasing to note that there was a great increase in Profile 2 for this sitting.

The examining committee once again reminds candidates and teachers of Biology to make use of the subject reports posted on the CXC website as they provide detailed comments by the examining committee on the performance of candidates on each question.

## DETAILED COMMENTS

### Paper 01 — Multiple Choice

Paper 01 consisted of 60 multiple-choice items. The mean score for Paper 01 was 35.72, compared with 35.14 in 2019. Some of the topics that were more problematic for candidates include:

- Digestion
- Immunity
- Transport in animals
- Adaptations of a plant for water
- Excretion
- The structure of the skin and temperature regulation
- Correction of sight defects
- Genetics

### Paper 02 — Structured/Extended Essays

#### Question 1

This question tested Specific Objectives B 4.1, 4.2, 4.3, 4.7, 4.8, 4.9, 4.12 and 4.13. Additionally, three profile skill areas were assessed: Knowledge/Comprehension (KC), Use of Knowledge (UK) and Experimental Skills (XS).

The question assessed candidates' knowledge of transport in plants and animals including the role of transpiration in plants. Candidates were also assessed on plant and animal storage products and the importance of food storage in living organisms.

Out of a total of 25, candidates' marks ranged from 0 to 25 and the mean mark was 12.03.

Most candidates were able to score at least two of the four marks allocated to Part a (i). This was mainly due to their ability to accurately name two organs involved in transpiration. A few candidates confused transpiration with respiration.

Part (a) (i) required candidates to briefly describe the process of transpiration in plants. The description had to include the names of two of the organs involved in transpiration.

**Expected Response (any of the following)**

- Process of water movement through the roots and stem of the plant
- Movement of water from the xylem (stem) and roots in a continual flow (transpiration stream)
- Movement of water along a concentration gradient (water leaves the soil and enters the root hairs and continues upward)
- Water evaporation from the leaves
- Water leaves the plant through the stomata

Candidates received credit for mentioning any two of the following organs: *roots, stems, leaves, flowers*. A large number of candidates erroneously referred to the xylem and phloem as organs when they are tissues.

One candidate earned full marks for providing the following response:

In plants, water is first taken up by the roots via osmosis. Water is transported through plants via the xylem vessels. Due to low pressure at the top of the xylem, water easily flows up the xylem. The low pressure is due to the constant evaporation of water from the leaves of the plant.

Part (a) (ii) presented a table entitled 'The Effect of Relative Humidity on the Rate of Transpiration'. The table contained results in Column A for Relative Humidity and Column B provided corresponding data for the Rate of Transpiration. Candidates were asked to draw a graph of the results.

This part of the question was very well done and candidates were able to construct the graph correctly. However, candidates need to be reminded of the following points when constructing graphs:

- Use appropriate labels including the correct units on both axes.
- Use appropriate titles.
- Use an appropriate scale: more than half of the graph paper (relative to both axes) should be used in the construction of the graph.
- The graph should not be a line of *best fit* unless that is asked for specifically.

The expected graph is shown below. It should be noted that candidates were not penalized for interchanging the axes because the question was not explicit about the independent and dependent variables.

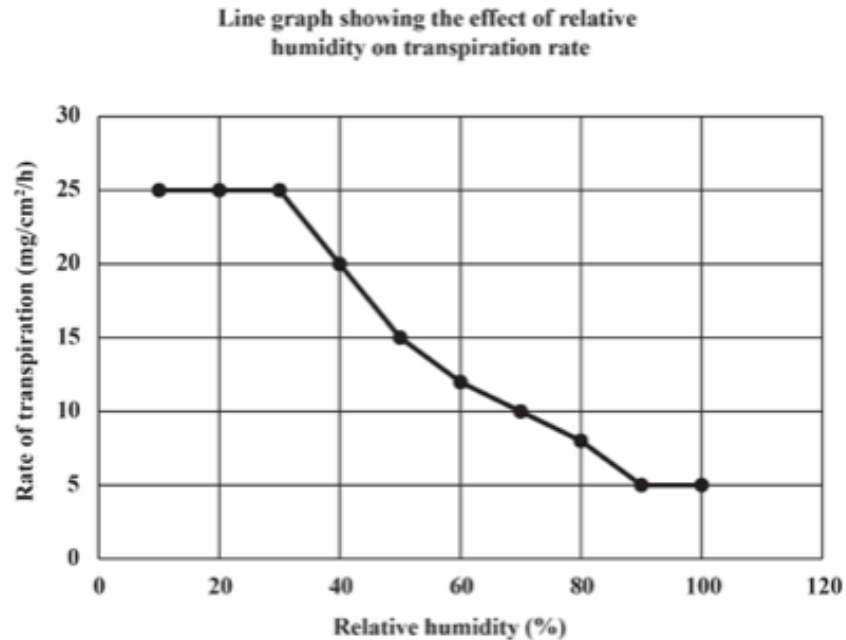

Part (a) (iii) asked candidates to use the results from the given table to state how the rate of transpiration changes as the relative humidity changes.

**Expected Response (any of the following)**

- The rate of transpiration decreases when relative humidity increases.
- The rate of transpiration is higher when the relative humidity is lower.

Many candidates were able to score this 1 UK mark.

With regard to Part (a) (iv), candidates were asked to suggest two ways by which the results in the given table supported the answer they gave in Part (a) (iii). Many candidates gave the same answer they had provided for Part (a) (iii), whereas the question required extraction of the data from the table to support what they had written in Part (a) (iii).

Two supporting ways with reference to the table include the following:

- High rate of transpiration at low relative humidity (10–30 per cent)
- With increase in relative humidity (40–80 per cent), the transpiration rate decreases from 20mg/cm<sup>2</sup>/h
- Transpiration rate drops to 5 mg/cm<sup>2</sup>/h when the relative humidity is greater than 90 per cent; at this point the amount of water in the atmosphere is greater than the relative humidity within the leaf.

The following response was categorized as satisfactory.

Because at 10 per cent the rate of transpiration is  $25 \text{ mg/cm}^2/\text{h}$  and then at 50 per cent the rate of transpiration decreased to  $15 \text{ mg/cm}^2/\text{h}$  and at 100 per cent the rate of transpiration further decreased to  $5 \text{ mg/cm}^2/\text{h}$ . As humidity increases the amount of water droplets in the environment increases which keeps the plant cool, therefore transpiration cannot occur.

For Part (a) (v), candidates were given the statement: *A farmer observed that his plants wilted during the day but recovered at night.* Candidates were required to suggest to the farmer one reason for this occurrence. Candidates performed well on this part of the question; they were able to recall the factors that affect transpiration. Any one of the following responses would have given the candidate the UK mark.

- Increase in transpiration during the day
- Decrease in transpiration during the night
- Increase in water loss during the day
- Decrease in water loss during the night
- High humidity at night
- Low humidity during the day
- High light intensity
- High temperature
- Much air movements/high winds

Part (b) (i) asked candidates to suggest two ways in which the animal transport system and the plant transport system are different.

The following response was considered a satisfactory one.

Plants transport system include the xylem and phloem whilst the animal transport system includes the blood, capillaries, veins, arteries and the heart.

Plants transport minerals and salts via it being dissolved in water whilst animals transport food through dissolved material in the blood.

Candidates could have noted any of the differences shown in the following table.

<b>Plants</b>	<b>Animals</b>
Transport vessels in plants are phloem and xylem.	Transport vessels in humans are capillaries, veins and arteries/ (blood vessels).
Movement of water throughout plants is facilitated by transpiration/root pressure/capillarity.	In animals, the movement of blood in and around the body is facilitated by the heart.
In plants, water and sugars are transported.	In animals, blood/plasma is transported.
Substances such as minerals, sugars and amino acids dissolved in water are transported in plants.	Substances such as antibodies and hormones dissolved in plasma are transported in animals.
In plants, water is carried by the xylem vessels and sugars are carried by the phloem vessels.	In animals, there is no distinction in the substances carried by the blood vessels.

Part (b) (ii) required candidates to differentiate between the transport needs of a unicellular animal and a multicellular animal. Not many candidates handled this part of the question satisfactorily. There appeared to have been some confusion about the relationship between surface area and volume in organisms. Though there was a general understanding of multicellularity, candidates did not convey an appreciation for the fact that a transport system is needed because of the limitation of diffusion as the sole means of exchange of substances throughout the organism.

### Expected Responses

The following table summarizes what was expected.

<b>Unicellular</b>	<b>Multicellular</b>
Relatively small and can get the substances they need (and get rid of waste) by diffusion	Relatively large so they require a transport system
Large surface area to volume ratio allows substances to move in and out of the organism easily	Small surface area to volume ratio so substances do not move into the organism easily
Small volume so substances do not have to go very far (no blood or elaborate transport system is needed)	Large volume so an elaborate transport system is needed

One satisfactory response is given in the following exemplar.

In unicellular organisms, due to their size it is easy for their needed materials to diffuse or undergo osmosis over their membrane. However, in multicellular organisms, due to their size and multiple cells needing

nutrients, a transport system is needed because osmosis and diffusion cannot just simply occur.

Part b (iii) was generally well done; most candidates were able to obtain at least one of the two marks allocated. The question required candidates to explain why food storage is important, making reference to one storage site in animals.

Though approximately 50 per cent of the candidates could not give a storage site, many of them were able to explain the importance of food storage in organisms.

**Expected Response (any of the following)**

- Storage of glycogen in the liver or muscle to overcome the need for continuous food intake.
- Storage as fat deposits in the liver or skeletal muscle would provide for periods of scarcity.
- Plants store fats in seeds, using the seeds for energy storage.
- Plants store carbohydrates in the roots, leaves, fruits and stems to provide energy.
- Storage of fat under the skin of animals to provide warmth or for food during hibernation.

The following example is an adequate response received from one candidate.

Food storage is important because on the occasion that the organism cannot get food, it should be able to call upon its food reserve, for example, humans store food in the adipose tissue. Food is needed because this is where animals and plants get their energy.

Question 2

This question tested Specific Objectives B 1.1, 1.2, 1.3, 1.4, 1.6 and 1.7. Additionally, the two profile skill areas assessed were Knowledge/Comprehension (KC) and Use of Knowledge (UK). Out of a total of 15, candidates' marks ranged from 0 to 15 and the mean mark was 8.48.

In this question, candidates were required to compare the structure of the generalized plant and animal cells, distinguish between cell wall and cell membrane, and differentiate between plant and animal cells.

Candidates were given a diagram showing the internal structures of a generalized plant cell, and in Part (a) (i), they were asked to identify six structures labelled A–F.



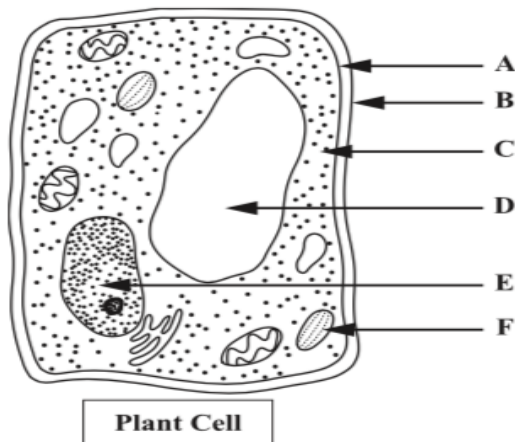

### Expected Response

- A — plasma membrane OR cell membrane
- B — cell wall
- C — cytoplasm
- D — vacuole (cell sap was accepted)
- E — nucleus
- F — chloroplast

Some candidates did not know the difference between the cell membrane and the cell wall so they were unable to correctly identify those two structures. Candidates also encountered some difficulty differentiating between the chloroplast and mitochondrion and so incorrectly labelled 'F' as 'mitochondrion'. There were, however, very few scripts where candidates failed to score in this part of the question.

Part (a) (ii) asked candidates to differentiate between plant and animal cells. Candidates were required to identify two differences and explain how each difference is important to the plant's existence.

Generally, candidates were able to identify the differences but many of them did not follow through by answering the second part of the question. A few of them listed 'the shape of the cell' as a difference but that is inaccurate and was not accepted.

### Expected Response

Candidates could have given answers based on the information in the following table.

Difference	Reason
Plant cells have chloroplast and animal cells do not	The chloroplast is the site of photosynthesis.
Plant cells have a cell wall and animal cells do not.	The cell wall supports/ maintains the shape of the cell and structure of the plant OR Cell wall protects the plant from pathogens.
Plant cells have starch grains and animal cells do not	Plants photosynthesize, producing starch (sugar stored as starch)
Plants have a large vacuole and if present in animal cells it is small.	Large vacuoles store unwanted materials and some nutrients OR Contribute to the rigidity or turgidity of cells
Plants have chlorophyll; animal cells do not	Plants photosynthesize, using chlorophyll which traps light.

The following is an example of one acceptable candidate response.

Plant cells have vacuoles and animal cells (generally) do not. Vacuoles are for storage of food materials, water and minerals. The vacuoles also store waste materials.

Plant cells have chloroplasts and animal cells do not. Chloroplasts are important for the manufacturing of chlorophyll which is important for photosynthesis.

Part (b) (i) required candidates to state the expected observation if each of the cell types (plant cell and animal cell) was placed in distilled water for 15 minutes. The question further required candidates to suggest one reason for each observation.

This part of the question was not well done because candidates did not apply the theory about the difference in permeability of the cell wall and cell membrane. *The cell membrane is differentially permeable while the cell wall is freely permeable.* Since this application was not made to the plant and animal cells, most candidates earned two or less than two of four marks.

## Expected Response

### *Plant Cell*

Observation: The plant cell becomes turgid/swollen

Reasons: Because it absorbs water, the plant cell retains its shape due to the presence of a strong cellulose cell wall

### *Animal Cell*

Observation: The animal cell becomes swollen and then burst

Reasons: The cell membrane is a weak structure which cannot withstand the pressure and the cells burst/lysis occurs/there is no cell wall to protect the cell.

Part b (ii) required candidates to name the process which is responsible for the observation in Part (b) (i). Many candidates were able to correctly state *osmosis*.

## Question 3

This question tested Specific Objectives B.7.6 and 7.10. Additionally, the two profile skill areas assessed were Knowledge/Comprehension (KC) and Use of Knowledge (UK). Out of a total of 15, candidates' marks ranged from 0 to 15 and the mean mark was 2.39.

In this question, candidates were required to apply the process of accommodation and explain the correction of sight defects. Candidates were provided with a diagram showing a boy reading a book under a tree while his friends play in the distance. Part (a) required candidates to describe the process by which the structure of the boy's eye will allow him to (i) read the book and (ii) observe his friends playing in the distance.

This question performed poorly, and in some instances, candidates did not appreciate that *accommodation* was the process which should be described. In other instances, candidates had the correct information but mixed up the content for (ii) with (i) and vice versa. Moreover, candidates in many cases stated that the 'muscles' carried out the action. They were unable to correctly state that *the actions were carried out by the ciliary muscles or the suspensory ligaments*.

## Expected Responses

### (i) *Process for Reading the Book*

- Eyes adjusted for near vision – lens is thickened/rounded/more convex/bulging (to bend light onto the retina)
- Ciliary muscles contract
- Tension released on suspensory ligaments/suspensory ligaments slacken

- Pupil gets smaller (because the book is close)

(ii) *Process for Viewing Friends playing in the Distance*

- Lens become thin/flattened/less convex to see distant objects (also lens become elongated/stretched)
- Ciliary muscles relax
- Tension on ligaments attached to the lens/suspensory ligaments tighten
- Pupil widens (because the friends are at a distance/far away)

Part (b) (i) required candidates to name the type of corrective lens which would help the boy see distant objects clearly if he is near-sighted. Many candidates were able to correctly state *concave/divergent lens*. However, in some instances, candidates provided incorrect answers because they wrote the lens for long-sightedness instead.

For Part (b) (i), candidates were given the statement: *John is nearsighted but his sister Mary has normal vision*. Candidates were then asked to state what would cause John's sight to be different from Mary's?

One candidate provided the response below and received one of the two possible marks.

John's eyeball may be too long and so when viewing distant objects, the light reflected from those objects focus/meet in front of the retina

To receive the full two marks for this response, candidates had to clearly state that what caused John's sight to be different from Mary's was what happened in John's case versus what happened in Mary's case.

**Expected Response**

*In John's case, the light rays from a distant object will converge in front of the retina whereas in Mary's case the light rays converged on the retina.*

In some instances, candidates stated that *for John, his lens were more convex or the eyeball was too long (from front to back), the lens were too curved or too thick*. In these instances, candidates still received the mark.

Part (b) (ii) asked candidates how wearing corrective lenses/glasses would allow John to see objects as clearly as Mary.

**Expected Response**

*The lens will bend the light rays outwards/light rays diverge (spread out) before entering the eye causing them to converge on the retina.*

In some instances, candidates provided a drawing to illustrate what would occur. Full marks were awarded if candidates provided a correct illustration.

Part (c) required candidates to explain why the appearance of the boy's eyes while seated under the shade of the tree would be different from their appearance if he is seated in the sun.

Similar to Part (a), candidates had the correct information but mixed up what would happen to the pupil, the radial and the circular muscles in the sun versus in the shade. Moreover, candidates mixed up the actions of the radial and circular muscles.

### Expected Response

Candidates were awarded full marks for providing any two of the three comparisons.

Feature	When under the tree	When in sun
Pupil size	wide open/dilates	Small/constricts
Radial muscles	contract	Relax
Circular muscles	relax	contract

### Question 4

This question tested Specific Objectives A 3.6, 5.1, 6.1, 6.2, 6.4 and 6.5. Additionally, the two profile skill areas assessed were Knowledge/Comprehension (KC) and Use of Knowledge (UK). Out of a total of 15, candidates' marks ranged from 0 to 15 and the mean mark was 7.58.

In Part (a), a simplified diagram of the carbon cycle was provided. Candidates were required to name the processes labelled A, B, C and D. Most candidates were able to score at least two of the four marks allocated to this question.

### Expected Response

- A — Respiration
- B — Photosynthesis
- C — Decomposition
- D — Combustion

Weaker candidates referred to Process A as transpiration. For Process C, some candidates incorrectly stated decomposers; this was not accepted. However, *decay* was accepted. Some candidates incorrectly referred to Process D as the burning of fossil fuels instead of stating the process.

In Part (b), candidates were required to suggest three human activities that increase the levels of carbon in the ecosystem and for each activity, they had to state one way the activity increases the level.

Most candidates were able to suggest the activity, but some had difficulty showing how the activities contributed to increased carbon levels.

Some of the accepted activities were:

- deforestation
- industrialization
- increased use of electricity by humans
- increase in waste from human (decomposition)
- transportation activities, for example, cars, airplanes
- smoking
- burning materials containing carbon.

For each activity named, candidates were credited for stating the way in which carbon levels were increased, for example, *plant population acts as carbon sinks so removing them by deforestation would cause carbon dioxide levels to increase or transportation use fossil fuels which release carbon dioxide in the air.*

Some of the misconceptions stated were:

- fire extinguishers increase carbon dioxide levels in the ecosystem
- air conditioners lead to increased carbon dioxide levels.

Part (c) asked candidates to suggest three practices that can be adopted to reduce the impact of human activities on the carbon cycle.

### **Acceptable Response**

- Using electric/hybrid vehicles
- Turning off lights or TV when not in use
- Planting more trees
- Supporting industrial products which use renewable energy resources, for example, solar, wind
- using eco-friendly products, for example, biogas
- Adhering to good practices through laws/legislation/penalties/fines

Positive practices were accepted but reduction in negative practices were not. For example, 'cutting down less trees' was not accepted. Candidates would have had to state instead, *plant more trees*. Also, an answer such as 'burning less rubbish' was not accepted. Only the better candidates got full marks for this question.

Part (d) required candidates to name two greenhouse gases other than carbon dioxide. Gases accepted were:

- methane
- nitrous oxide
- water vapour
- CFCs
- ozone (O<sub>3</sub>)

Many candidates were able to score one of the two marks. 'Carbon monoxide' was frequently named but this was not accepted.

### Question 5

This question tested Specific Objectives B 4.6, 10.1 and 10.5. Additionally, the two profile skill areas assessed were Knowledge/Comprehension (KC) and Use of Knowledge (UK). Out of a total of 15, candidates' marks ranged from 0 to 15 and the mean mark was 7.10.

In this question, candidates were required to compare a pathological condition with a physiological condition, explain the process of vaccination and provide strategies for managing hypertension.

For Part (a), candidates were required to complete a table. The following is an example of a correctly completed table.

<b>Characteristic</b>	<b>Hypertension</b>	<b>Yellow Fever</b>
Disease category	physiological/non-communicable/degenerative/lifestyle	Infectious/communicable/pathogenic
Disease cause	Disease results from malfunctioning body tissues/organs  Dietary/lifestyle indiscretions (high salt intake, lack of exercise, tobacco smoking, genetics, increased stress)	Disease caused by invading pathogens/virus
Sign/symptoms	headache, rapid heart-beat, elevated systolic/diastolic BP reading	Jaundice/ yellow eyes, severe headache behind the eyes, severe muscle pain, very high fever accompanied by chills/loss of appetite

Generally, candidates were able to receive at least four of the six possible marks. Marks were lost because candidates wrote the sign/symptoms for hypertension as the disease cause and in other cases, candidates were not able to correctly state the disease categories for the two conditions. Most candidates were able to write one correct sign/symptom for the two conditions.

Part (b) required candidates to explain how vaccination works to prevent persons from becoming ill with yellow fever. Marks were awarded if candidates provided any three of the five following points.

- A mild form of the yellow fever virus antigens are injected into a person's body/a weakened or mild form of the pathogen is injected.
- The person's lymphocytes produce antibodies (and memory cells).
- Memory cells recognize the yellow fever antigens if they enter the body again/thereafter if the pathogen re-enters the body, the body will be able to fight it off to prevent infection.
- Memory cells quickly divide to form more lymphocytes like themselves.
- These secrete large amounts of the antibody that can destroy that antigen.

#### Common Misconceptions

- Antibodies are injected into the body
- The virus is injected, that is, candidates did not specifically state that a weakened or mild form of the pathogen is injected

For Part (c), candidates were asked to discuss three strategies that can be used by hypertensive patients to control their signs/symptoms.

For this question, candidates had to provide a strategy and explain how the strategy could be used to control the sign/symptoms of hypertension. In many instances, candidates only received three of the six marks because they stated only the strategy but failed to provide an explanation as to how the strategy would control the condition. Acceptable responses are summarized in the following table.

Strategy	Explanation
Dietary changes	Include less saturated fat (increase fiber and vegetables in the diet) because high intake of saturated fat may lead to arterial plaques which narrow the lumen of the arteries resulting in increased blood pressure. <b>OR</b> Eat less salt because the use of salt creates the possibility of increase in blood pressure.



Strategy	Explanation
Exercise	Improves cardiovascular function: regular exercise enhances the strength and endurance of the heart. Aerobic exercise helps to clear fatty deposits from blood vessel walls resulting in smoother blood flow.
Stop smoking	Nicotine causes intense vasoconstriction/narrowing of the lumen of blood vessels; the narrower the vessel, the higher the blood pressure.
Reduce alcohol intake	Chronic alcohol consumption causes vascular damage which eventually leads to an increase in blood pressure; completely avoiding alcohol will therefore assist with the lowering of the BP.
Take medications (or herbal remedies)	Taking medications prescribed by the physician to lower the elevated blood pressure (or correct any of the signs/symptoms).
Relaxation techniques	Engage in stress relief activities which are relaxing and calming, for example, yoga etc. as a means to reduce the blood pressure.

### Question 6

This question tested Specific Objectives B 7.2, 7.11 and C 2.8. Additionally, the two profile skill areas assessed were Knowledge/Comprehension (KC) and Use of Knowledge (UK). Out of a total of 15, candidates' marks ranged from 0 to 15 and the mean mark was 6.51.

In this question, candidates were required to describe how the human skin helps the body to keep cool on a hot sunny day, to identify similarities and differences between humans and invertebrates in the ways they keep cool and to draw a genetic diagram based on information provided.

For Part (a), candidates were required to describe how the human skin helps the body to keep cool on a hot, sunny day. Candidates received marks for describing the cooling effect and providing any of the following six points:

- Hair erector muscles relax
- Hairs lie flat
- No insulating layer of air is present

- Blood vessels and arterioles dilate/expand
- Vessels move closer to the surface
- Blood flow through skin increases
- Blood loses heat
- Sweat is produced
- Sweat evaporates; evaporation of sweat removes heat from the body
- Moving air gets closer to the skin and removes heat

Part (b) required candidates to state one similarity and one difference between human beings and invertebrates in the ways they cool their bodies on hot days. Many candidates were able to state a similarity. The most popular response was *both can drink water*. However, candidates lost marks because they did not represent the answer for the differences as a compare and contrast.

The following example was an acceptable response to the question.

- *Similarity:*  
Humans and invertebrates can physically move from hot areas to shaded areas/cool areas.  
OR  
Both can drink water.
- *Difference:*  
Humans can regulate/lower their own body temperature, however, invertebrates are unable to regulate their body temperature.

For Part (c) (i), candidates were provided with the statement: *Persons with the inherited condition albinism do not produce the pigment (melanin) that gives the skin its dark colour*. Candidates were required to draw a genetic diagram to illustrate how two heterozygous parents could produce an albino child. In their diagram, they were to use the symbol 'A' to represent a normal allele and the symbol 'a' to represent the albino allele.

### Expected Response

Parent Genotype:                    Aa    X    Aa  
Gametes:                            A   a                    X   A   a

Outcome of Random Fertilisation/Punnet Square: AA Aa Aa aa

Many candidates failed to provide a response and many others provided an incomplete genetic diagram. Candidates should be reminded to clearly show the parental genotype and gametes in the diagram.

While Part (c) (i) required candidates to identify the genotype of the albino child, Part (c) (ii) required the candidate to state the probability of the albino child being produced.

Many candidates correctly stated the genotype as  $aa$ . However, many who performed a correct cross stated the incorrect probability. Probability can be expressed in many ways. As such, candidates received the mark if they provided any of the following answers.

- $\frac{1}{4}$
- *0.25 or 25 per cent*
- *1 in 4*
- *1:3*

### **Paper 032 — Alternative to School-Based Assessment (SBA)**

#### **Question 1**

This question tested Specific Objectives B 2.3, and 2.6. Additionally, the two profile skill areas assessed were Experimental Skills (ORR and MM), and Use of Knowledge (UK). Candidates were expected to draw and label the external features of a dicotyledonous leaf and perform tests for proteins, fats, and starch. Out of a total of 20, candidates' marks ranged from 0 to 20 and the mean mark was 9.10.

In Part (a), candidates were given Sample A – crushed, cooked potatoes; Sample B – powdered full-cream milk; and test reagents. The test procedure was provided and candidates were asked to describe their observations of both samples (A, then B) when treated with Biuret reagent, potassium iodide solution and alcohol or Sudan III, and to then state their inferences. Of the total of 12 XS marks allotted to Part (a), few candidates scored more than six marks.

#### **Observations**

- Some supervisors' reports were missing. Supervisors must ensure that a report is sent to CXC concerning the conduct of the practical with full observations.
- A few centres appeared to have switched the samples: The milk was labelled as Sample A, and the cooked potatoes as Sample B. This was not the information that was provided in the question. Care must be taken to ensure that candidates have samples that are clearly and accurately marked before the commencement of the examination.
- The theory underlying the basic food tests was not clearly understood by many of the candidates. Many candidates could not comprehend the significance of the color changes observed so incorrect inferences were made.
- A few candidates tried to state their inferences by writing chemical equations. It should be noted that equations representing the chemical changes involved in the formation of the blue-black color

in the starch test, or the purple color in the Biuret test are complex and are not required at this level. Candidates' efforts therefore proved futile as they were unable to represent the changes accurately using chemical equations.

- Some candidates gave a general inference, for example, 'both substances contained starch' or 'protein present', without indicating the sample to which they were referring. An inference should have been made for each substance tested because a general inference is not applicable to both samples given.

Candidates should note that Specific Objective B 2.6 states that "students should be able to perform tests to distinguish among food substances". The performance of candidates on this part of the question shows clearly that this objective has not been realized because many candidates were unable to distinguish among proteins, lipids and starch (carbohydrate).

In Part (b) (i), candidates were asked to make a large drawing of the leaf provided and label it. Candidates need to be reminded of the following guidelines used for drawing as stated on the CSEC syllabus.

- The drawing should be placed in a position on the page which will allow for neat and clear labelling.
- Drawings should be done in pencil. (Some candidates used a pen to draw the leaf.)
- Write labels in pencil.
- The drawing should be correctly proportioned, and parts should be accurately positioned.
- Smooth, unbroken lines are required.
- Label lines should never intersect and should be horizontal where possible.

Some candidates managed to make a drawing of the specimen but were unable to label it or gave incorrect labels. Many candidates referred to the petiole as the stem.

The 6 XS marks allocated to this part of the question were awarded based on the following:

Drawing (One mark)

- Clear lines

Accuracy (One mark)

- Structures typical OR
- Structures proportional

Labels (One mark each for any four labelled correctly)

- Leaf apex
- Leaf margin
- Leaf vein
- Lamina

- Midrib
- Petiole

Part (b) (ii) asked candidates to calculate the magnification of their drawing. Marks were awarded for the formula, that is, for showing working (one mark) and for showing the answer (one mark).

Magnification seemed unfamiliar to most of the candidates. The CSEC syllabus states that “drawings must have a full title and magnification” so this needs to be taught and reinforced/implemented.

The few candidates who knew the formula seemed mostly oblivious of the significance of the ‘X’ sign which precedes the number, so they received just the one mark for showing working. Most candidates failed to score on this part of the question.

### Question 2

This question tested Specific Objectives B 8.3. Additionally, planning and design skills were assessed. Candidates were given a scenario for which they were required to appropriately plan and design an experiment and record the expected results. Out of a possible 20, candidates’ marks ranged from 0 to 17 with the mean mark being 7.30.

This question was generally well answered. Most candidates were able to use their knowledge and experimental skills to answer all the parts.

In Part (a), candidates were informed that a farmer obtained broccoli seeds and wanted to find out which of three temperature conditions is best for germination. Candidates were therefore required to plan and design an experiment which would advise the farmer of the best temperature for planting broccoli seeds. Candidates were required to provide a suitable hypothesis, procedure and expected results.

Most candidates were able to attain one or two marks in this section because they were able to write a hypothesis that was testable, feasible and related to the problem.

However, some candidates wrote the hypothesis in the format of an aim and as such, no marks were awarded. They used phrases such as ‘to determine’ or ‘to find out’. If candidates wrote a hypothesis which included a temperature condition and utilized words like *germination best or more seeds will germinate*, they were awarded the marks.

The procedure was also mostly well done. Candidates were able to score marks with their procedure once it was feasible and followed basic planning and designing skills. Candidates were required to include the following steps/points in the procedure:

- Measuring the amount of soil or water

- Use of labels
- Replication (having more than one set)
- Setting up a control
- Large sample size
- Use of correct tense (present/command)
- Standardization

Some candidates did not standardize the measurements and wrote about 'some seeds' and 'an amount of water'. A common misconception is that 'seeds need light for germination'. Many candidates also failed to write the procedure methodologically and hence they did not score the mark for placing the steps in order. Some candidates also confused growth with germination and hence mentioned measuring length and height of shoot to indicate that germination had taken place.

Generally though, candidates scored well on this section. In some instances, marks were lost because the hypothesis was incorrect but most candidates were able to state that *the germination rate will be highest in the field compared to the other two conditions*.

In Part (b), candidates were required to state two possible sources of error in the experiment design. Most candidates scored well on this section as they were able to identify errors in the procedure which could affect the validity of the results, for example,

- variation in temperature
- variation in moisture/water
- seeds not being viable.

However, some of the candidates frequently mentioned sunlight as a source of error which was a major misconception. Also, some of the weaker candidates incorrectly stated that there were errors in measuring the height/length of the stem. Again, they were mixing up growth experiments with germination.

In Part (c), candidates were required to suggest three reasons why water is essential for seeds to germinate. The better candidates were able to attain at least two of the three marks. Candidates were not always able to relate the function of water to germination because they were incorrectly mentioning 'photosynthesis' as the reason why water was essential.

Some of the better candidates were able to link water to the following:

- Enzymes activation
- Hydration of cells
- Facilitating the bursting of the testa
- Hydrolysis and chemical reactions

### Question 3

This question tested Specific Objectives A 1.2, 2.1; C 2.7 and 2.8. Out of a possible 20, candidates' marks ranged from 0 to 20, with the mean mark being 13.29. In this question, candidates were required to observe nine organisms which were collected by a biologist from his home garden.

Part (a) required candidates to state three visible characteristics that can be used to classify the organisms into two groups. Candidates generally performed well in this section; they were able to identify three of the following characteristics.

- Presence of Wings
- Number of legs
- Number of body segments
- Presence of antennae
- Mouth parts

Part (b) required candidates to use one of the characteristics identified in Part (a) to complete a table to show how the organisms can be classified into two groups. Some candidates were able to receive full marks on this part of the question. Candidates who failed to receive full marks made the following mistakes:

- Classification was done based on more than one characteristic; for example, presence of wings for Group A and number of legs for Group B
- Failure to place organisms correctly based on the chosen characteristic; for example, if a candidate chose presence of an antennae as a characteristic, there was the erroneous inclusion of an organism in the column which did not have an antenna.

However, marks were awarded if candidates were able to classify the organisms by their characteristics, for example, *Presence of wings for Group A* and *Absence of wings/No wings for Group B*. Also, candidates scored the marks if after choosing an appropriate characteristic, they were able to correctly list the organisms in the appropriate column.

Part (c) (i) required candidates to name an instrument that the biologist could have used to collect the organisms and in Part (c) (ii) they were required to state how the instrument is used.

#### **Expected responses**

- Use of a Net — Gently sweep net through the air above the garden to collect the organisms.
- Use of a jar — Use a shovel/scoop to collect organisms, then place them in container/jar.

Part (d) required candidates to state two precautions that the biologist should have taken when collecting the organisms. Generally, candidates were able to receive marks on this part of the question. Acceptable responses included the following:

- Not to crush/kill the organisms
- Wear protective clothing so as not to get bitten/stung

Many candidates correctly stated sweep net, jar, or pooter and provided an appropriate use. For Part (ii), some candidates did not score the mark if they stated, for example, that 'the sweep net would be used to collect the organisms'. The candidate needed to state **how** to use the sweep net.

Part (e) required candidates to use a formula to calculate the number of butterflies in a population. Many candidates were able to receive full marks for this part of the question. The two marks were awarded for correctly setting up the equation and obtaining the correct answer. Candidates lost a mark for incorrect computations, despite correctly setting up the equation.

Part (f) required candidates to utilize the information provided and draw a genetic diagram to show the codominance of a particular trait. Candidates continue to perform poorly in genetic questions; candidates were unable to correctly draw the genetic diagram and make relevant conclusions from the cross. Marks were awarded if candidates correctly included the following:

- Parental phenotypes
- Parental genotypes
- Results of the cross
- Offspring phenotype
- The phenotypic ratio for the trait required in the stem



**CARIBBEAN EXAMINATIONS COUNCIL**

**REPORT ON CANDIDATES' WORK IN THE  
CARIBBEAN SECONDARY EDUCATION CERTIFICATE<sup>®</sup>  
EXAMINATION**

**JULY/AUGUST 2020**

**BIOLOGY  
GENERAL PROFICIENCY**

**Copyright© 2020 Caribbean Examinations Council  
St Michael, Barbados  
All rights reserved.**

## GENERAL COMMENTS

The July/August 2020 sitting of the CSEC Biology examination consisted of two papers: Paper 01, Multiple Choice and Paper 032, Alternative to School-Based Assessment.

With regard to overall performance, 74.13 per cent of candidates obtained Grades I–III in 2020 compared with 77.30 per cent in 2019 and 72.96 per cent in 2018.

With regard to performance by paper, 88.64 per cent of candidates obtained Grades I–III on Paper 01 in 2020 compared with 84.73 per cent in 2019 and 83.75 per cent in 2018. For Paper 030 (School-Based Assessment), 87.64 per cent of candidates obtained Grades I–III in 2020 compared with 84.96 per cent in 2019 and 84.54 per cent in 2018. For Paper 032, 13.81 per cent of candidates obtained Grades I–III in 2020 compared with 10.14 per cent in 2019 and 4.36 per cent in 2018.

For Profile 1 (KC), 76.11 per cent of candidates obtained Grades A–C compared with 72.93 per cent in 2019 and 72.26 per cent in 2018. For Profile 2 (UK), 64.09 per cent of candidates obtained Grades A–C compared with 46.89 per cent in 2019 and 52.38 per cent in 2018. For Profile 3, 69.84 per cent of candidates obtained Grades A–C compared with 95.80 per cent in 2019 and 95.89 per cent in 2018.

The mean score for Paper 01 in 2020 is 42.57 compared with the mean score of 39.41 in 2019 and 39.14 in 2018.

## DETAILED COMMENTS

### Paper 01 — Multiple Choice

Paper 01 consisted of 60 multiple-choice items. The mean score for Paper 01 was 41.37. Some of the topics that were more problematic for candidates include the following:

- Autotrophic organisms
- Photosynthesis
- Locomotion
- Simple reflexes
- Glaucoma
- Genetics
- Genetic engineering

## Paper 032 — Alternative to School-Based Assessment

### Question 1

This question tested Specific Objectives B 1.6, 1.7 and 4.1. The profile skill areas assessed in this question were Measurement and Manipulation (M/M); Observation, Reporting and Recording (O/R/R); and Planning and Designing (P/D). Marks ranged from 0 to 26 out of a total of 33 and the mean mark was 10.74.

This question required candidates to manipulate and measure agar cubes to determine surface area/volume ratios and the degree of colour penetration after the cubes were placed into potassium permanganate solution for varying periods of time. Candidates were also required to make accurate observations followed by concise recording and reporting of what they observed. Additionally, having been given the aim of an investigation and appropriate apparatus and materials, candidates were required to use their planning and designing skills to correctly describe an experiment that could be used to conduct the investigation.

Part (a) required candidates to calculate the surface area to volume ratio of two given cubes of agar (one large and one small). Candidates had difficulty dealing with the concept of surface area of a cube, specifically forgetting that the six sides of a cube must be considered in the formula. The concept of volume was better understood. Some candidates were able to calculate the surface areas and volumes accurately but seemed unfamiliar with actually expressing the surface area to volume ratio. This concept should be emphasized during students' instruction because it is fundamental to an understanding of the rate of diffusion of materials into and out of cells.

Part (b) tested candidates' ability to accurately record experimental observations and provide a suitable title for the experiment they carried out. Most candidates scored well on this part of the question. Two marks were awarded for accurate data pertaining to the large cube and two marks for accurate data pertaining to the small cube. Data provided in the supervisor's report was used as the standard for determining accuracy. One mark was also awarded for an appropriate title for the experiment. A suitable title would have been *Colour Penetration of a Large and a Small Cube with Time*.

Part (c) required candidates to formulate a suitable hypothesis for the experiment they had conducted and Part (d) asked them to state one likely source of error for the experiment. The more capable candidates received full marks for both parts. However, other candidates, though generally able to score the mark in Part (d), failed to score the marks for Part (c) because they wrote the hypothesis as an aim. What was required was a clear, testable statement related to the observations. For example, one candidate wrote the hypothesis: *The rate of diffusion of potassium permanganate in the smaller cubes is quicker than the rate of diffusion in the larger cubes.*

For Part (d), some candidates stated 'measurement' or 'time' as their response to the question. No mark was awarded for those responses because they were incomplete and vague. A complete response would

have been *measurement of the cube/measurement of the potassium permanganate solution/inaccurate timing*. Candidates are reminded of the necessity to utilize complete, specific answers; they should avoid sacrificing specificity for brevity just because the question is only worth one mark.

Part (e) tested candidates' skills in planning and designing an experiment. They were provided with the aim, materials and equipment for an experiment and were asked to provide a suitable experimental procedure that could be used to conduct the investigation. Many candidates were familiar with the functions of the given equipment and materials (glass tube; litmus paper; dilute ammonium hydroxide solution; concentrated ammonium hydroxide solution; forceps; timer) and were able to earn the four marks for providing an appropriate, workable procedure that could be used to conduct the investigation.

Part (f) asked candidates to state two precautions that should be taken when conducting the experiment described in Part (e). Most candidates scored well on this part of the question because they were able to state precautions specifically relating to the conduct of the experiment.

Part (g) required candidates to draw a suitable graph to represent data presented in a given table. Eight marks were allotted to this question using the following breakdown:

- Appropriate key: 1 mark (Since two sets of data were to be graphed on the same graph paper, a key was absolutely necessary to differentiate between the two graphs.)
- Axes correctly labelled with the units stated: 2 marks
- Appropriate scale: 1 mark
- Points plotted accurately: 4 marks

Generally, candidates showed competence in constructing the graphs accurately but there were instances where, to candidates' detriment, basic procedures for the following were disregarded.

- Correct labelling of axes
- Correct scales
- A key to explain symbols/different graphs

Part (h) required candidates to state two similarities between the process occurring in the experiment described in Part (e) and that which occurred in the experiment they conducted. Most candidates seemed to misunderstand this part of the question; they focused on similarities in the method (timing) instead of on similarities between the occurrences in the processes. Any two of the following similarities would have given candidates the two marks allotted to this part of the question:

- Both gas and liquid molecules move by diffusion.
- The movement of molecules takes place from regions of higher to lower concentration of the molecules/the movement of molecules takes place along a concentration gradient.
- No membrane was present.
- Both experiments took place in non-living systems.

Part (i) provided candidates with the following as stimulus material:

Mineral salts dissolved in soil water move into root hairs, even though the concentration of these salts within the root cell cytoplasm is generally higher than that in the soil.

Candidates were then asked to describe the process by which salts are absorbed by the root hairs. Some candidates were able to identify the process as *active transport* but could not describe it accurately. Others incorrectly described it as 'diffusion'.

The following is an acceptable response from a candidate: *Mineral salts are absorbed from the soil as ions dissolved in water. They are absorbed by root hairs and move by active transport through the cortex of the root against a concentration gradient.*

Part (j) asked candidates to explain why red blood cells would burst when placed into distilled water for some time but onion epidermal cells would become turgid and not burst when placed in distilled water for the same period. This part of the question was worth two marks. Many candidates encountered difficulty providing explanations. Even though they seemed to know of the presence of the plasma membrane in the red blood cell and a plasma membrane and cell wall in the onion epidermal cell, their responses were not specific. For example, many candidates focused on the absence of a cell wall in the red blood cell, rather than the presence of a plasma membrane, which is very fragile and would burst when placed in a hypotonic solution for some time.

Candidates must desist from writing about non-existent structures unless specifically asked for those. Instead, they should focus on the structure that serves a particular function. In this part of the question, many candidates stated the structural difference between the two cells (in terms of presence and absence of cell walls) but did not elaborate on how that difference caused the cell to burst or remain intact.

The following are demonstrations of what was expected of candidates in their responses.

Animal cells have a plasma membrane which will burst when the cell absorbs too much water while plant cells have a plasma membrane and a cellulose cell wall which make them very strong; so they remain turgid and do not burst.

OR

When water enters animal cells by osmosis, the cell cytoplasm expands beyond the capacity of the plasma membrane to remain intact, and the cell bursts, whereas when water enters plant cells, they become turgid but do not burst because of the strong cellulose cell wall.

Overall, the performance of candidates in this question showed that they were familiar with the objectives examined. The results therefore identify a grave need for candidates to explore answering techniques on how to selectively extract information from their memory and apply it accurately to a relevant part of the

question. Reading the question hurriedly may also be responsible for some of the inaccuracies encountered.

### Question 2

This question tested Specific Objectives A 2.1, 3.1 and 3.2. This question was worth 20 marks and the marks ranged from 0 to 18 with the mean mark being 7.88.

In this question, candidates were required to analyse data and construct an appropriate food chain, pyramid of numbers and determine appropriate sampling techniques for identifying and capturing lizards.

In Part (a), candidates were given a table with data showing the number of species on an abandoned farm. For Part (a) (i), candidates were required to construct a food chain using the data from the table. Most candidates were able to obtain the two marks allocated to this question by using all five organisms from the table and using arrows that point from organisms being consumed to their consumers.

For Part (a) (ii), candidates were required to construct a pyramid of numbers using data from the table. By doing the following, most candidates were able to score the three marks allocated to this question.

- Placing the primary producers at the base
- Representing all the organisms from the table
- Representing each type of consumer by the appropriate size in the pyramid
- Showing the secondary consumers below the tertiary consumers

Some candidates failed to use the name of the species but used the numbers instead; they were given the mark in this instance. A few candidates constructed an inverted pyramid of numbers, however, no marks were awarded for this.

In Part (b), candidates were required to explain one way in which the numbers of a particular species may change if the snakes were killed. Most candidates were able to score one out of the two marks allocated to this question. They were expected to give a change in the number of a named species for one mark and the reason for the change for the other mark.

The full two marks would have been awarded for any of the following responses.

- If all the snakes were killed, the number of lizards would increase since snakes are the predators of lizards.
- The number of grasshoppers may decrease since there would be more lizards around to eat them.
- The hawks may decrease in number because they would have less food if all snakes were killed (source of food removed).
- The quantity of savannah grass would increase because less of the grass would be eaten.

Some candidates did not name a species and they just mentioned that the species numbers may change without indicating whether those numbers would increase or decrease. Hence, no marks were awarded.

For Part (c), candidates were required to describe one sampling method that could be used to estimate the density of savannah grass on a farm. This was fairly done with some candidates being able to score two out of four marks. Most candidates were able to identify *the quadrat* as the sampling method. However, some candidates failed to state that the quadrat would be randomly thrown and said in fact that the quadrat would be placed. Moreover, some candidates stated unrealistic dimensions of the quadrat, for example,  $1\text{cm}^2$ . Some other candidates incorrectly gave 'the line transect' as the sampling method.

Any one of the following responses was acceptable.

- Divide farm into sections using random numbers
- Throw quadrat randomly
- Throw quadrat along belt transect
- Recount/count the number of stems in each grid/quadrat
- Calculate or average the number of plants per unit area

Candidates could also have stated the dimensions of the quadrat.

Part (d) required candidates to suggest one reason why the sampling method used for estimating the density of grass would not be suitable for estimating the density of lizards. This was done very well where most candidates were able to score the mark by indicating that *lizards are mobile and would move out of the quadrat before being counted*.

In Part (e), candidates were asked to give a description of one sampling method that would be suitable for sampling the population of lizards. This section was generally poorly done. Few candidates obtained full marks. Some candidates incorrectly named a piece of equipment as the method, for example, 'traps', 'pitfall traps', 'quadrats'.

Expected responses include the following:

- Capture/recapture/release method
- Capture lizards/count/mark
- The release of marked lizards
- Recapture lizards in a second sample
- Count the number of marked lizards in the second sample
- Estimate the total number of lizards in the area using the formula

For Part (f) candidates, were required to outline how one piece of equipment may be used to catch the lizards. Candidates were expected to name a piece of equipment and give a reasonable explanation of how that piece of equipment can be used to catch lizards. Some candidates were able to attain at least one of the two marks allocated. Some candidates incorrectly mentioned 'beating trays', 'cage', and 'shaking of the tree' to collect the lizards.

Acceptable responses include the following:

- Use sweep nets/nets to sweep the grassy areas and capture lizard
- Traps/pitfall traps/baited traps to catch the lizard

To enhance performance in this area, instructors can incorporate more practical activities and fieldwork into the lesson plans. Moreover, instructors should afford students the opportunity to practice the construction of food chains and pyramids using data collected from simple ecological studies.

### Question 3

This question tested Specific Objective B 3.5. The question was worth 15 marks and marks ranged from 0 to 11, with the mean mark being 7.7.

In this question, candidates were required to analyse data presented about the volume of oxygen inhaled per kilogram of body weight for three individuals.

Part (a) (i) required candidates to plot a suitable graph to represent the data. Candidates received full marks if they

- used a bar chart to represent the data
- labelled both the x and y axes
- plotted all three bars correctly
- used an appropriate scale.

Candidates are reminded that graphs should, where possible, utilize at least 50 per cent or more of the graph paper. To achieve this, an appropriate scale should be chosen. Moreover, care should be taken to plot points accurately because in some instances, candidates lost marks during this process. The majority of candidates represented the data as a bar chart; however, in some instances candidates drew a line graph or left the points as stand-alone points. The latter two methods were not suitable for representing the data.

Part (a) (ii) required candidates to suggest one factor which should be considered when collecting this data. Candidates received marks for stating any of the following suggestions: *age, weight, height, sex, health, level of physical activity, job/nature of the job, diet.*



Part (a) (iii) required candidates to state one conclusion that can be drawn from the results obtained. Most candidates correctly responded by stating one of the following responses:

- Smokers consume/inhale less oxygen than non-smokers.  
OR  
Non-smokers consume/inhale more oxygen than smokers.
- Smoking reduces the amount of oxygen consumed per minute.
- Athletes take in/consume more oxygen per minute than sedentary persons.

In some instances, candidates stated conclusions that could not be drawn from the results, for example, the store manager is more active than the bank manager. Candidates should note that for questions of this nature, conclusions should be drawn directly from the results; they should abstain from making conclusions/assumptions based solely on their everyday experiences.

Part (b) (i) required candidates to suggest two reasons for the difference in the results for the athlete and the store manager. Candidates generally stated the following points:

- Athletes train more/exercise more/are fitter.  
OR  
Store managers train less/exercise less.
- Athletes use more oxygen for performance.  
OR  
Store managers use less oxygen for performance.

Other suitable responses include the following:

- Athletes have more muscle mass.  
OR  
Store managers have less muscle mass.
- Athletes have a greater vital capacity  
OR  
Store managers have a smaller vital capacity.
- Athletes have more mitochondria  
OR  
Store managers have less mitochondria.
- Athletes carry out more aerobic respiration.  
OR  
Store managers carry out less aerobic respiration.

- Athletes have less oxygen debt.
- OR
- Store managers have more oxygen debt.

To obtain the full two marks, candidates were required to provide two reasons for the difference in the results rather than simply providing a compare and contrast response. For example, the response 'athletes exercise more while store managers might exercise less' was awarded only one mark.

Part (b) (ii) required candidates to suggest one reason for the difference in the results for the smoker and the non-smoker. The majority of candidates were able to receive the mark by stating that *smokers' lungs are destroyed and hence they inhale less oxygen when compared to non-smokers*. However, any of the following points were accepted:

- Smokers' lung/alveoli destroyed
  - Smokers' alveoli have reduced surface area
  - Breathing is more difficult for a smoker
  - Reasons linked to health will be accepted
  - Smoking decreases the oxygen concentration/level in the body
- OR
- Not smoking will increase the oxygen concentration/level in the body

**C A R I B B E A N E X A M I N A T I O N S C O U N C I L**

**REPORT ON CANDIDATES' WORK IN THE  
CARIBBEAN SECONDARY EDUCATION CERTIFICATE<sup>®</sup>  
EXAMINATION**

**JANUARY 2021**

**BIOLOGY  
GENERAL PROFICIENCY**

**Copyright © 2021 Caribbean Examinations Council  
St Michael, Barbados  
All rights reserved.**

## GENERAL COMMENTS

Candidates' performance in 2021 was not as good as their performance in 2020 and 2019. In 2021, 53 per cent of candidates obtained Grades I–III, compared with 71 per cent in 2020 and 60 per cent in 2019.

For Profile 1 (Knowledge and Comprehension (KC)), 56 per cent of candidates obtained Grades A–C in 2021 compared with 67 per cent in 2020 and 70 per cent in 2019. For Profile 2 (Use of Knowledge (UK)), 41 per cent of candidates obtained Grades A–C in 2021 compared with 59 per cent in 2020 and 42 per cent in 2019. With respect to Profile 3 (Experimental Skills (XS)), 73 per cent of candidates obtained Grades A–C in 2021, compared with 90 per cent in 2020 and 71 per cent in 2019.

The mean score (37.15) for Paper 01 in 2021 was higher than the mean score in 2020 (35.72) and 2019 (35.14). With reference to Paper 02, the mean score for 2021 (34.36) was lower than the mean score in 2020 (44.10) and the mean score in 2019 (38.52). For Paper 032, the mean in 2021 (16.13) was lower than the 2020 mean (19.79) and the 2019 mean (19.38).

Generally, candidates experienced difficulty applying their knowledge. This was evidenced by the consistently higher scores in Profile 1 (KC) when compared with Profile 2 (UK).

The examining committee once again reminds candidates and Biology teachers/instructors to make use of the subject reports posted on the CXC website as they provide detailed comments on the performance of candidates on each question. Additionally, specific guidance is provided as applicable in the detailed comments provided for Paper 02 and Paper 032.

## DETAILED COMMENTS

### Paper 01 — Multiple Choice

Paper 01 consisted of 60 multiple-choice items. The mean score for Paper 01 was 37. Some of the topics that were more problematic for candidates included the following:

- Function of the xylem
- Structure and function of blood components
- Function of the kidney
- Excretion
- Simple reflex action
- Structure of the eye
- Acquired immune deficiency syndrome (AIDS)
- Deoxyribonucleic acid (DNA)
- Genetic crosses

## Paper 02 — Structured and Extended Essays

### Question 1

This question tested Specific Objectives B 2.8, 2.9, 2.10, 2.11 and 4.5. The total marks gained for this question ranged from 0 to 24, out of a possible total of 25. The mean mark was 9.46.

Candidates were required to explain the role and importance of enzymes; to investigate and explain the effects of pH on enzyme activity; to describe the products of digestion of starch; to provide dietary recommendations for treating and preventing deficiency diseases; and to describe the role of the blood in defending the body against disease.

In Part (a), candidates were asked to state two reasons why enzymes are referred to as *biological catalysts*. Some candidates were able to state that enzymes *speed up or increase the rate of biochemical reactions*, but too many failed to mention the presence of enzymes in living cells.

Part (b) presented a graph showing the results obtained from an investigation of the effect of pH on the action of the enzyme amylase. In Part (b) (i), the candidates were asked to record the results shown on the graph in a suitable table. This was the best-done section of the question as most candidates were able to draw the enclosed table with the required features of columns, headings with the unit of time, accurate values and the appropriate title. Candidates were not penalized if they did not include the corresponding unit of time. A large majority of the candidates used a ruler to construct and enclose the table. This is to be commended.

Part (b) (ii) asked candidates to suggest two reasons for the shape of the graph during pH 4-5 and pH 6-8 by referring to the rate of enzyme activity. Many candidates seemed to have difficulty with the concept of longer time meaning a lower rate. Many of them failed to mention that the time taken to digest the starch would be longer at lower rates of the reaction. Too many candidates gave descriptions rather than explanations regarding the relationship between the rate of enzyme activity and the specific pH ranges. Additionally, some candidates were unfamiliar with the pH scale and the use of the term *optimum*, as the best operating pH. Some candidates even used pH and temperature interchangeably, maybe because they are more familiar with the factor temperature.

In Part (b) (iii), candidates again displayed their inability to interpret data and offer a reasoned explanation for the U-shape. There is a need for higher-order operations to be deliberately taught to students during instruction, so that the UK skills, which generally carry a higher weighting, can be applied successfully.

Any of the following responses would be deemed correct:

- The graph has a U-shape because the rate of activity of amylase increased, then decreased.
- The enzyme becomes denatured after pH 6 and the rate of activity decreases.

- The enzyme exceeded its optimum pH (after pH 6) and the rate of activity decreased.
- The structure of the enzyme molecule changes and the substrate does not fit as well into the active site.

Part (b) (iv) asked candidates to predict how many seconds it would take for amylase to completely break down starch at pH 5.5. Some candidates were able to accurately read off the required values from the graph; however, others did not read the values carefully and so were not credited with the mark. The expected answer was 29 seconds (28 seconds was also accepted).

In Part (b) (v), candidates were asked to determine the optimum pH of amylase which, from the graph, was 6. Some candidates correctly identified the optimum pH. Others seemed not to understand the term *optimum pH*.

Part (b) (vi) asked candidates to predict the pH at which amylase would completely break down starch in 80 seconds. Many candidates did not use a ruler in order to ascertain the corresponding point on the graph and gave erroneous values such as 4.5.

Part (c) required candidates to provide a description of a suitable procedure that could be used to investigate the effect of pH on the time taken for amylase to digest starch. Many candidates performed fairly well on this part of the question and were able to score at least three of the five available marks. Marks were awarded for correct steps, for example, *mixing the enzyme with starch, adding iodine as an indicator, observing a colour change and standardization of the measurement used*. Candidates were also given credit for mentioning *alkaline, neutral and acidic pH*, even if they did not specify each of the pH values used to construct the graph.

Most candidates gained full marks for Part (d). The following response is one of those that gained full marks.

If the food molecule is too large, salivary amylase will take a longer time to break down the food molecule. Considering this statement, suggest two ways in which mammals can decrease the time they take to break down food molecules.

Part (e) required candidates to match deficiency diseases to the vitamin or mineral. Many candidates correctly identified scurvy as the deficiency caused by a lack of vitamin C. Some candidates did not seem to know that the abnormal clotting of blood can be due to a deficiency of vitamin K, calcium or iron.

In Part (f), candidates were asked to explain one way in which white blood cells and platelets defend the body against disease. This section was generally well done, as candidates' responses indicated that there was a clear understanding of the role of white blood cells and platelets. Some candidates had difficulty distinguishing antigens from antibodies.

Teachers are reminded that past papers are a valuable resource. These papers provide guidance regarding the style of questioning adopted by CXC, the most frequently set concepts and the many skills and competencies which students of Biology must possess.

### Question 2

This question tested Specific Objectives B 1.3, 2.2, 2.3 and 2.4. Marks ranged from 0 to 15, out of a total of 15. The mean mark was 4.16.

The question required candidates to relate the structure of organelles to their functions; to describe the process of photosynthesis in green plants; to relate the structure of the leaf of a flowering plant to its function in photosynthesis; and to explain how environmental factors affect the rate of photosynthesis.

In Part (a), candidates were given a diagram of the cross-section through the leaf of a flowering plant and in Part (a) (i) were asked to label specific structures identified on the diagram. Most candidates seemed to be familiar with the diagram but despite this, quite a number of them were unsuccessful in correctly identifying the labelled parts. The labelled structures were:

- A: Upper epidermis/upper epidermal cell
- B: Palisade cell/palisade layer
- C: Vascular bundle/leaf vein (Xylem vessel was also accepted.)
- D: Spongy mesophyll cell (Spongy cell or spongy layer was accepted.)

Part (a) (ii) required candidates to suggest one way in which photosynthesis would be affected if all of the air spaces in the leaf of the flowering plant were filled with cells. Many candidates knew the importance of the diffusion of carbon dioxide in photosynthesis and related the passage of the gas (in air) to the presence of air spaces in the leaf.

In Part (b), candidates were asked to list three ways in which the leaf of a plant is adapted for photosynthesis. Candidates were competent in their handling of this section of the question. Since no explanation was required, most of them earned two to three marks of the allocated three.

Part (c) (i) asked candidates to state if there is any difference between the function of plant chromosomes and the function of animal chromosomes, and Part (c) (ii) asked them to state a reason for the answer to Part (c) (i). Most candidates did not know that there is *no functional difference between plant and animal chromosomes*, so they focused on differences that were unrelated to chromosomes. Consequently, their answers to Part (c) (ii) were incorrect. In this part of the question, any of the following responses would have been acceptable:

- In plants and animals, chromosomes carry genetic information in the form of DNA.
- The chromosomes are involved in cell division to produce new cells.

- Both sets of chromosomes are involved in cell division to produce new offspring.

Part (d) presented a graph showing the rate of photosynthesis versus carbon dioxide concentration. Candidates were asked to describe different regions of the graph: A (where the concentration of carbon dioxide was low) and A–B (where there was an increase in the rate of photosynthesis, up to a maximum).

Most candidates found the descriptions to be problematic as they did not seem to know that the *low concentration of carbon dioxide correlated with the low rate of photosynthesis*. However, many of them understood that *in order for the rate of photosynthesis to increase, the plant needed more carbon dioxide, so increasing the concentration of carbon dioxide increased the rate of photosynthesis*.

In Part (e), candidates were given the following scenario:

Despite the increase in the global concentrations of atmospheric carbon dioxide, there is no corresponding increase in the rate of photosynthesis in flowering plants. Suggest one reason for this observation.

Only the more capable candidates understood the concept of limiting factors. Those candidates stated that other factors such as *light, temperature and water could be limiting the reaction and, hence, photosynthesis*. It must also be remembered that *carbon dioxide can itself be a limiting factor because when the maximum rate of carbon fixation is reached, the rate of photosynthesis remains constant*.

### Question 3

This question tested Specific Objectives B 1.1, 1.3, 2.2, 2.3 and 2.4. Marks ranged from 0 to 15, out of a total of 15. The mean mark was 5.21.

In this question candidates were required to have knowledge of the structure of plant and animal cells and the movement of molecules across cell membranes. Additionally, they needed to analyse an investigation on the effects of concentration on the rate of diffusion and appreciate that diffusion is a vital process in living organisms.

Part (a) required candidates to list four structures that are common to both plants and animals. Most candidates scored well on this part of the question. They were able to score at least three out of the four allotted marks by listing any four of the following structures: *cell membrane, cytoplasm, nucleus, mitochondria, nucleolus, chromosomes, vacuole, ribosomes*.

Some candidates had problems spelling the structures correctly. However, marks were awarded once spellings were phonetically correct.

Part (b) required candidates to define diffusion, osmosis and active transport. Most candidates were able to score at least two out of the three marks, mostly for diffusion and osmosis. They correctly stated that



diffusion is *the movement of particles from an area of high concentration to an area of low concentration* and osmosis *the movement of water molecules from a high water concentration to a low water concentration through a selectively permeable membrane.*

Many candidates described the membrane as semipermeable which was accepted as a benefit of the doubt point. Teachers are reminded when teaching the concept to emphasize that *the membrane is selectively/partially/differentially permeable.* Many candidates were unable to define active transport which as *the movement of molecules across a membrane from a region of low concentration to a region of high concentration requiring energy.*

In Part (c), candidates were given a picture of an apparatus which was used to investigate the effect of concentration on the rate of diffusion. Dilute and concentrated ammonium solutions were used. Part (c) (i) required candidates to state the expected results. Most candidates were able to correctly state that *litmus paper will change colour faster in the concentrated solution.* Some of the less capable candidates failed to link the rate with concentration. Instead, they just stated that the length of time taken for each piece of the litmus paper to change colour will be shorter. As such, the marks were not awarded.

Part (c) (ii) required candidates to explain the results stated in Part (c) (i). This part was not well answered as candidates failed to give a correct explanation. Acceptable responses include the following:

- The rate of diffusion depends on the concentration of the solution.
- The concentrated ammonia solution will create a steeper concentration gradient so there will be faster diffusion.
- The concentrated solution will contain more molecules than dilute solution.
- More molecules mean that more molecules will come into contact with the litmus paper, thus causing the litmus paper to change colour faster.

Part (d) required candidates to discuss four ways in which diffusion is important to mammals. This part was poorly answered. Many candidates linked importance to the mechanical process of breathing. Some examples of inaccurate responses include the following:

- For infiltration in the Bowman's capsule of kidney
- Digestion
- Heat regulation
- Cells excrete waste.
- For smelling

Marks were awarded if candidates stated any four of the following points:

- Oxygen diffuses from alveoli into the blood.
- Carbon dioxide diffuses into the alveoli from the blood.
- Oxygen diffuses from the blood to body cells.

- Nutrients enter the blood from the small intestine.
- Carbon dioxide from baby to mother.
- Oxygen/nutrients from mother to baby across placenta.
- Nutrients/waste diffuse in and out of the kidney.

In order to improve the performance of students, teachers can use a more practical approach to teaching osmosis and diffusion. Also, animated videos can be used to teach active transport.

#### Question 4

This question tested Specific Objectives C 2.1, 2.2, 2.3 and 6.1. Marks ranged from 0 to 13, out of a total of 15. The mean mark was 2.85.

The question required candidates to have knowledge of the process of mitosis and its importance to living organisms. Candidates were also required to demonstrate knowledge of animal cloning with respect to its advantages and disadvantages.

Part (a) required candidates to sequentially describe the process of mitosis. Many candidates were able to score some marks. Marks ranged from zero to six. Candidates who scored zero had no knowledge of this process. Some candidates also incorrectly described meiosis.

A few candidates also incorrectly mentioned that the chromosomes (not chromatids) move from the centre of the cell towards the poles. During marking, marks were made accessible for this question such that one mark was awarded for describing at least four points in logical order. Marks were awarded for the following:

- Chromosomes appear.
- Chromosomes shorten, thicken and duplicate themselves.
- Each chromosome consists of two identical chromatids joined at the centromere.
- Nucleolus disappears.
- Centrioles separate forming spindle fibres between/on both sides of the cell.
- Nuclear membrane disappears.
- Spindle forms between centrioles.
- Chromatic pairs/chromosome line up around the equator of the spindle.
- Centromeres split and chromatids separate and move to opposite poles of the cell/chromosome split or start to separate.
- Cell constricts at equator — cleavage.
- Nuclear membrane forms around each set of chromosomes.
- Cell divides forming two identical daughter cells.
- Each daughter cell has a diploid number of chromosomes/identical to parent cell.
- Nucleolus forms in each nucleus.

In Part (b), candidates were given stimulus material stating that “Animal cloning farming practices ensure many benefits to farmers and consumers worldwide.” In addition, they were told that “according to the European Food Safety Authority (2007), there is an increased frequency of health risks to animals involved in the cloning process”. Candidates were required to state two advantages and one disadvantage of animal cloning. Many candidates were able to score at least two of the three marks. A few candidates incorrectly linked advantages to crops. Hence, no marks were awarded. Acceptable responses regarding advantages include the following:

- Creates more food security/no food shortage/faster food/more animals/good quality products
- More sales/business/profits for farmers
- Could have scientific discoveries in other fields/genetic research/help scientists do research
- Creates exact duplication/exact replica
- Allows us to preserve endangered species/prevents extinction
- Helps to reduce human disease/eradicate disease
- Creates desirable traits
- Restores lost species
- No need for sexual reproduction or mate
- Removes the barrier of infertility

Acceptable responses regarding disadvantages include the following:

- It is expensive.
- Reduces genetic diversity of species.
- It has a history of creating abnormal pregnancies.
- Results in sterility issues.
- Could result in cancer-related issues.
- It is the least effective way to produce offspring.
- Usually unsuccessful/reduces lifespan.
- It is unethical/immoral.
- May lead to embryo destruction.
- Animals born alive may have health problems or other abnormalities or birth defects.
- Because of no variation, animals not well adapted to change in environment/if one animal is diseased all can get disease/are susceptible.

Part (c) required candidates to explain three ways, other than cloning, in which the process of mitosis is important for organisms. Three marks were awarded for the ways and three marks for the explanation of each way. This part was poorly answered. Many candidates who stated the ways failed to provide explanations and were awarded only half of the marks. Many candidates stated reproduction as a way instead of *asexual reproduction*; hence no marks were awarded.

Any three of the following responses with an explanation would have gained six marks:

- Growth and development — produces new cells/number of cells increases
- Repair of cells — replaces damaged cells
- Asexual/vegetative reproduction — occurs in some animals, as the only type of reproduction/produces identical copies of a single cell
- Conservation of genetic material genetic — genetic information remains unchanged from generation to generation/similar information from parent to daughter cell/same genotype and phenotype as parent
- Regeneration/can replace body parts like tails or leg — new cells produce

To enhance students' performance on this question, teachers can use video clips to explain. Also, students can be given the opportunity to build models of the stages of mitosis.

#### Question 5

This question tested Specific Objectives A 3.7 and B 10.6. Marks ranged from 0 to 14, out of a total of 15. The mean mark was 7.27.

Candidates were required to identify reasons for movement; list the three types of symbiotic relationships and identify the type of symbiotic relationship which existed based on a given scenario. Candidates were also required to provide logical explanations based on a given scenario.

In Part (a), the three symbiotic relationships were tested. Candidates generally scored well in this section but it should be noted that care should be taken to spell biological terms correctly. Correct responses included *parasitism*, *commensalism* and *mutualism*.

In Part (b), candidates were required to identify the type of symbiotic relationship which existed for three scenarios. Candidates were able to obtain at least one or two marks out of a possible three marks. Candidates are reminded that although there may be similarities between information presented and scenarios encountered from previous exposure, questions of this nature should be answered only based on the information presented. For example, one scenario stated that *a remora attaches itself to a shark and travels with the shark to feed on leftover food scraps from the shark's meal*. However, based on the scenario presented, the expected response is *commensalism*. The other scenarios and answers are as follows:

- An epiphyte grows on a tree and obtains support and its roots do not enter the soil — commensalism.
- There are worms in a dog's intestines which cause the dog to become ill — parasitism.

In Part (c), candidates were presented with a scenario about a farmer who lived next door to someone who had pet birds that got ill with the 'bird flu'. The contaminated faecal droppings of the infected birds

affected the farmer's livestock and plants. Candidates were required to explain any three implications that the spread of the 'bird flu' infection would have on the farmer's livestock or vegetables. It was also noted that the implications could be positive or negative and they may be social, economic or environmental. Candidates were generally able to score at least three of the six allocated marks for this question. There were many acceptable responses some of which included the following:

- The bird flu will contaminate crops and animals, and this can lead to lower yields. When yields decline or crops and herds are lost, there is often an increase in food prices.
- Due to the increase in diseased produce, Mr Brown is not able to sell his produce to other countries because countries do not purchase products from countries where there are crops or animals with diseases.
- Mr Brown is unable to sell his animals or vegetables to make money and this will lead to a loss of income for him and his family and possibly a financial crisis for them.
- A loss of income due to the loss of revenue from his crops may lead Mr Brown to develop unhealthy habits (drinking, smoking etc.) because he may become depressed since he is no longer able to provide for his family.

For this question, candidates were required to fully explain three implications to obtain six marks. Many candidates simply listed implications and provided no explanation to accompany them. Teachers should emphasize the meaning of key words, such as *explain*, in questions.

In Part (d), the stem stated that animals move from place to place so that they do not become ill. Candidates were required to list three other reasons why animals on a farm should be allowed to move from place to place. Some candidates lost valuable marks here because they did not focus on the stem and instead listed reasons linked to avoiding illness. Candidates who received marks stated the following:

- To find a mate/reproduce
- To escape predators/danger
- To find food
- To reduce competition (or to prevent overcrowding)
- To disperse offspring
- To avoid extreme weather
- Exercise

### Question 6

This question tested Specific Objectives B 4.3, 10.1 and 10.5. Marks ranged from 0 to 15, out of a total of 15. The mean mark was 5.42.

The question tested candidates' knowledge of hypertension, diabetes, the valves of the heart and the difficulties which may arise from having abnormal valves. In Part (a), candidates were required to label

three valves of the heart. Once again, candidates should ensure that they are able to accurately spell required terms. Marks were awarded for stating three of the following:

- Tricuspid/atrioventricular
- Bicuspid/mitral/atrioventricular
- Semilunar/pulmonary valve
- Semilunar/aortic valve

In Part (a) (ii), candidates had to label the valves identified in Part (a) (i). Many candidates correctly listed the valves in Part (a) (i) but could not identify and label the valves in Part (a) (ii).

In Part (b), candidates were required to state a difficulty which could occur as a result of an abnormal heart valve. Generally, candidates were able to obtain this mark and were awarded for stating any one of the following responses:

- Shortness of breath/difficulty breathing, pain, heart attack or cardiac arrest/blood clots/alterations in blood pressure/dizziness/inability to take part in strenuous activities/irregular heartbeat
- Abnormal blood flow/blood may flow in the wrong direction
- Mixing of oxygenated and deoxygenated blood

Part (c) asked candidates to outline how the cause of diabetes differs from the cause of hypertension. In some cases, candidates lost marks for providing incomplete responses. For example, they did not present the information in a compare and contrast format, and only stated the cause of one condition and not the other. Two of the acceptable responses are as follows:

- Hypertension is caused by stress whereas diabetes is caused by the inability of the pancreas to produce enough insulin.
- Hypertension is caused by an intake of too much salt/sodium whereas diabetes is caused by an excess of carbohydrates.

In addition to stress and excess sodium, some candidates were able to identify many other causes of hypertension, for example, *lack of exercise, smoking and alcohol*.

Part (d) required candidates to compare the methods used to manage diabetes and hypertension by outlining two similarities and two differences in these methods. The similarities part of the question was done better. As with Part (c), candidates did not present the response in a compare and contrast format. For example, many candidates only stated how to manage one condition and not the other. As mentioned previously, teachers need to ensure that students fully understand how to formulate their responses based on specific key words in the question stem.

Candidates received two marks for stating any two of the following similarities:

- Both use medication.
- Both require exercise.
- Both require changes to the diet.

Two of the acceptable differences are as follows:

- Hypertension could be managed by reducing the amount of salt in the diet (or reducing stress or cholesterol) whereas diabetes could be managed by reducing the amount of carbohydrates (or glucose).
- Hypertension may be managed by daily use of oral medications whereas diabetes may require the daily use of injectable insulin.

### **Paper 032 — Alternative to School-Based Assessment**

#### Question 1

This question tested Specific Objectives B 3.1 and 3.2. Marks ranged from 0 to 17, out of a total of 21. The mean mark was 6.53.

The question required candidates to describe the process of aerobic respiration and to distinguish between aerobic and anaerobic respiration.

In Part (a), candidates were given instructions to set up equipment and materials to investigate the products of anaerobic respiration in yeast. The supervisors' reports indicated that the apparatus was set up as requested and that candidates were able to carry out the procedure given in the allotted time without much difficulty. A few candidates provided results that were not in alignment with what was reported by the centre supervisor but most results conformed to the supervisors'.

Generally, Part (a) (i) was fairly well done. It was evident that many candidates understood the nature of the products formed when yeast respire anaerobically. Candidates described the limewater turning milky or cloudy when fresh yeast was mixed with sugar solution and the gas produced was bubbled into limewater. Conversely, they reported the absence of cloudiness in the limewater that was attached to the tube with the boiled yeast. Many candidates also recognized the smell of alcohol in the boiling tube containing fresh yeast and described the absence of alcohol in the tube with boiled yeast.

Candidates from centres where supervisors found no observable reaction in both tubes — the one containing the fresh yeast and the other one containing the boiled yeast were not penalized.

Part (a) (ii) asked candidates to explain the reactions that occurred in Tube A (tube with the fresh yeast). Some candidates were unable to explain the reactions which occurred in Tube A but others scored well and referred to yeast respiring anaerobically, producing carbon dioxide and alcohol. A few candidates even wrote the chemical equation for the anaerobic reaction involving yeast. Others incorrectly stated that the sugar acts on the yeast to produce carbon dioxide and alcohol.

Part (b) asked candidates to state one reason why the water was boiled in Step 1 (of the given procedure). Many candidates did not understand the reason for boiling the water to remove the air and create anaerobic conditions; hence they mentioned the killing of microorganisms, to purify the water, and to remove all impurities. The desired response was one of the following:

- The water is boiled to remove the air. (Boiled water has no dissolved air.)
- The air or oxygen is driven off from the water.

In Part (c), candidates were asked to give a reason why boiled yeast was used in Tube B. This section was fairly well done as many candidates understood the reason for boiling the yeast, that is, to denature the enzymes present and thus it served as a control, even though in some cases the word *control* was not used but rather explained.

Part (d) asked candidates to state three functions of the liquid paraffin (or oil) used in the experiment. Most candidates were unsuccessful in identifying the functions of liquid paraffin but some of them correctly referred to the proper use of the paraffin as preventing air from getting into the tube; hence creating anaerobic conditions. Some candidates erroneously indicated that paraffin was used to trap the yeast solution and to prevent gas from escaping the mixture. Others said the paraffin was used to trap the air in the boiling tube.

Any two of the following points were accepted as suitable responses to this part of the question:

- Oil prevents the diffusion of oxygen. OR The oil ensures that aerobic respiration does not occur.
- The oil prevents the air from getting into the yeast-sucrose solution. OR The oil allows for anaerobic respiration to occur.

In Part (e) (i), candidates were asked to state two experimental variables that could be changed to measure the rate of production of the gas. Many candidates suggested temperature as a variable to be changed. On the other hand, quite a number of candidates did not seem to understand the concept of variables. *Temperature, pH, the concentration of the sugar solution and the mass of yeast used* were possible correct responses.

Part (e) (ii) asked candidates to state two variables that must be held constant if any one of the experimental variables listed in Part (e) (i) is changed to measure the rate of production of the gas. A few candidates suggested that the amount of sugar and amount of yeast should be held constant.



Candidates were asked to suggest a suitable hypothesis for this experiment. Many candidates still do not seem to know how to write hypotheses. Many are still writing hypotheses as though they are writing the aim of an experiment, beginning with the word 'To'. A few candidates were able to write a suitable hypothesis (one that is testable and feasible). For example, one candidate wrote, *Yeast produces carbon dioxide when it respire*s.

Part (g) required candidates to state two precautions that should be adhered to when conducting the experiment. Generally, this section of the question was well done. Candidates either wrote precautions relating to safety or precautions that can ensure reliable data.

Most candidates answered Part (h) by correctly identifying *bread-making* and *alcohol production* as industrial uses of yeast. The question asked candidates to use the results of the experiment to suggest two industrial uses of yeast. The results of the experiment were *carbon dioxide* and *alcohol*, which have many industrial uses.

## Question 2

This question tested Specific Objectives B 1.1, 1.6, 1.7 and 1.8. Marks ranged from 0 to 17, out of a total of 18. The mean mark was 8.80.

Candidates were required to design an investigation to observe the appearance of onion cells when placed in isotonic and hypertonic solutions. Planning and designing skills were required where candidates had to formulate an aim, hypothesis and design an experiment, using given materials and apparatus, and state precautions.

Part (a) required candidates to state a suitable aim for the experiment. Most candidates were able to score at least one of the two marks allotted to the question. Marks were allotted to the question as follows:

- One mark for noting that two samples will be compared/the effect or difference
- One mark for noting the two solutions (isotonic and hypertonic). For example, one candidate correctly wrote: *To observe the difference in an onion cell when placed in an isotonic solution and hypertonic solution.*

Candidates were expected to place 'To' at the beginning of the aim.

Part (b) required candidates to formulate a suitable hypothesis for the experiment. It was worth two marks. Marks were awarded for a testable and feasible statement. No marks were awarded if the hypothesis was stated as an aim. A response from a candidate that was allotted the two marks was as follows: *Onion cells remain unaffected in isotonic solutions but become flaccid in hypertonic solution.* This part of the question was fairly well done, with most candidates scoring at least one of the two marks.

Another suitable hypothesis was *Onion cells placed in an isotonic solution will/will not change appearance whereas the ones placed in a hypertonic solution will change appearance or become plasmolysed.*

To enhance candidates' performance in this area instructors can use a more practical approach in teaching osmosis. They can use animated videos and practise more plan and design activities to include the formulation of hypotheses that are testable (involving one variable and a statement) and feasible (can be done in a laboratory with available resources).

Part (c) required candidates to write a detailed procedure for the experiment using the two solutions and all of the materials listed. Most candidates performed well on this part, with many of them gaining the allotted eight marks for this section. Overall, the marks were awarded as follows:

- Two marks for use of all materials
- One mark for procedure written in logical order (at least four steps)
- Five marks for at least five steps

The marks allotted for procedure were awarded as follows:

- Peel the scaly outer leaves from the onion with scalpel.
- Cut the onion in half longitudinally with scalpel.
- Separate the fleshy storage leaves.
- Cut the onion with the scalpel into two thin slices.
- Remove/lift off the epidermal layer from the cut slices.
- Label two petri dishes A and B.
- Petri dish A will be used for the isotonic solution and Petri dish B will be used for the hypertonic solution.
- Place one of the slices of the onion/epidermal layer into Petri dish A (isotonic solution).
- After a reasonable time (about 1 to 5 minutes), mount the sample of the onion onto a microscope slide and observe the appearance of the cell.
- Place the other onion slice/epidermal layer in Petri dish B which has the hypertonic solution.
- After a reasonable time (about 1 to 5 minutes), mount the sample of the onion onto a microscope slide and observe the appearance of the cell.

Part (d) required candidates to state one precaution which should be observed when conducting the experiment. Many candidates were able to score the one mark allocated for this part by stating one of the following:

- The onion sample will be delicate so handle the onion cell with care so that the sample does not tear.

- Care should be taken to carefully cut a thin slice of the onion so that the cells can be visualized under the microscope.
- Do not contaminate or mix Solution A and Solution B.
- Place onion slice for same time in Solution A and Solution B.
- Place same amount/volume of solution in A and B.
- Avoid using outer scale leaf.

Some inaccurate responses were 'solutions should not be tasted; do not smell the solution; do not remove onion slices too soon'. No marks were awarded for such responses.

Part (e) required candidates to list three differences in the appearance of the cells during the experiment (in the isotonic and hypertonic solutions) based on Figures 2 and 3. This part was poorly done as many candidates failed to give a correct comparison and to make observations based on what they observed in Figure 2 and Figure 3. Some incorrect responses for which no marks were awarded were 'grey colour more in one than the other; one is opaque and the other translucent; there are small dots in one and the other is whole'.

Any three of the following points would have been awarded three marks:

- Cell in isotonic solution retains its normal shape while cells in hypertonic solution loses its regular shape.
- In isotonic solution cytoplasm retains the normal shape while in hypertonic solution cytoplasm shrinks.
- In isotonic solution cell membrane retains its normal shape while in hypertonic solution cell membrane pulls away from the cell wall.
- In isotonic solution the cell is turgid while in hypertonic solution the cell is flaccid/plasmolysed.

Part (f) required candidates to suggest one reason for the change in appearance of the cell in Figure 3 (hypertonic solution). Many candidates failed to score the one mark in this section because they failed to suggest that the change in appearance was due to osmosis. A good reason would have been that *when the cell is placed in a concentrated solution, water moves out of the cell into the surrounding solution and this leads to the change in the appearance of the cell in Figure 3.*

Part (g) required candidates to name the biological process which occurred during the experiment. It was worth one mark. This part of the question was well done as most candidates were able to identify the process as *osmosis*. Weaker candidates incorrectly stated the process as diffusion or respiration.

### Question 3

This question tested Specific Objectives C 2.7, 2.8, 2.9 and 2.10. Marks ranged from 0 to 21, out of a total of 21. The mean mark was 8.86. The question tested candidates' ability to accurately complete a genetic diagram and to use the information to make appropriate extrapolations.

In Part (a) (i), candidates were required to complete a table to represent the following information given in the stem: *A biology student conducted an experiment which revealed that in his class of 30 students 3 students were left-handed and 20 students could tongue roll.* This section was generally done well.

In Part (a) (ii), candidates had to use the table and construct a bar graph. In most cases, candidates were able to obtain two to three marks out of a total of five. The marks awarded for graphs are standard and therefore instructors should ensure that candidates are able to accurately plot the points to construct graphs. In addition, candidates are required to correctly label both axes and to choose an appropriate scale and title. Marks were lost for not labelling the axes or incorrectly plotting the points. For the most part, candidates were able to plot a bar graph.

In Part (b), candidates were asked to suggest one way in which the data collected for a group of students for tongue rolling differs from the data collected from the same group of students for height. Two marks were awarded for correctly stating that the *data collected for tongue rolling is discontinuous data and that the data collected for height is continuous data.*

In Part (c) (i), candidates were required to complete a genetic diagram based on the information given in the stem: *Colour blindness is a sex-linked recessive disorder. Draw a genetic diagram to explain why a man can never pass on the colour blindness trait to his son.* Candidates performed poorly on this question and this is becoming an unfortunate trend. Genetic diagrams are tested frequently and it is imperative that candidates adequately grasp how to draw them. As with graphs, the marks awarded for genetic diagrams are standard and given for

- an appropriate key defining the alleles
- correctly stating the phenotype and genotype of the parents
- completing the cross accurately
- an explanation of the results.

Part (c) (ii) required candidates to use the results from the genetic cross and state the genotype of a boy who does not have colour blindness. The correct response was  $X^N Y$ .

In Part (d), candidates had to state the parental phenotype and genotype for a child who does not have sickle-cell anaemia but whose father has sickle-cell anaemia. Candidates' performance on this question was also poor. An example of acceptable responses is shown in the table below.

	Male	Female
Parental phenotype	Male with sickle-cell disease	Normal
Parental genotype	SS  OR  ss	NS  OR  Ss or SS

Part (e) (i) required candidates to state the genotype of a person who has the sickle cell trait but does not have the disease. Interestingly, many candidates were able to get this question correct even with the incorrect information presented in Part (d). Acceptable responses included *NS or Ss*.

In Part (e) (ii), candidates were presented with a scenario and then required to suggest one reason why persons with the sickle-cell trait may be resistant to malaria. Candidates obtained this mark for stating any of the following:

- The person with the sickle cell trait has half of the red blood cells present with the sickle shape.
- The sickle shape of the red blood cells makes the person resistant.
- The red blood cells of the carriers are more fragile. When the parasite enters, the cells often burst before the parasite has time to develop and the parasite dies.